



OPERATIONS & PARTS MANUAL

FOR MODELS:

- BE-WCGF4R13
- BE-WCGF4H13

PURCHASE DATE	MODEL NO.	SERIAL NUMBER
DEALER		

TABLE OF CONTENTS

3	Specification
4	Section I - Safety
6	Safe operation practices
7	Section II - Assembly Instructions
8	Section III - Operation
11	Section IV - Chipping
15	Section V - Maintenance & storage
19	Removal, sharpening and re-installation of chipper knife
20	Instructions for adjusting or replacing belt
21	Centrifugal clutch tech tips
22	Troubleshooting
22	Lubrication & maintenance
22	Parts list
22	Parts diagram

SPECIFICATIONS

ITEM NO.	
Engine	Ducar/Loncin/B&S/Kohler/Honda
Displacement	420cc, 15hp
Chipping Capacity	120mm
Weight	260kgs
Length	2270mm
Width	1000mm
Height	1655mm
Operating RPM	3600 RPM
Type of Fuel	Petrol
Starting Method	recoil or E-start
Wheel tire	4.8-8 Vacuum tire
Cutting Method	Disc
Diameter	560mm
Thickness	20mm
Bearing	UCF208
Cutter Wheel RPM	2000 RPM/min
Knife No.	2 x knife, 1 x anvil
Packaging	Plywood case
Package Size	105*77*125cm
Gross Weight	270kg
Drive	Direct Belt Drive 17x900Li Centrifugal Clutch

SECTION I - SAFETY



This symbol points out important safety instructions which, if not followed, could endanger the personal safety and/or property of yourself and others.

Read and follow all instructions in this manual before attempting to operate your chipper. Failure to comply with these instructions may result in personal injury. When you see this symbol - heed its warning.

This machine is capable of inflicting serious injury if operated improperly -- read warnings & caution labels.

INTENDED USE

Never use your chipper for any other purpose than chipping limbs. It is designed for this use and any other use may cause serious injury

⚠ DANGER: ROTATING CUTTING BLADES

Keep hands and feet out of inlet and discharge opening while machine is running.

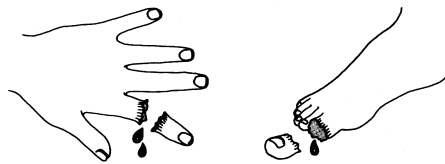

⚠ DANGER

This machine can CRUSH, GRIND, CUT, and SEVER parts of your body if they enter the inlet or discharge area of your chipper.

⚠ DANGER

Your chipper was built to be operated according to the rules for safe operation in this manual. As with any type of power equipment, carelessness or error on the part of the operator can result in serious injury. If you violate any of these rules, you may cause serious injury to yourself or others.

⚠ WARNING

The Engine Exhaust from this product contains chemicals known to the state of California to cause cancer, birth defects or other reproductive harm.

SAFETY LABELS

Make certain that all safety labels on this equipment are kept clean and in good condition. If you need replacement labels, order by part number.

DANGER

- Read and understand the operator's manual before starting and using unit.
- Keep all shields and guards in place and securely attached.
- Keep hands, feet, face, clothing and long hair out of infeed bin, and discharge chute while the engine is running. Rotating cutting blades inside these openings can cause serious personal injury. Material being processed may bounce back from inlet openings or be thrown from the discharge chute. Long hair or loose clothing may be pulled or sucked into the inlet openings.
- If the chipper jams or becomes clogged, immediately shut off the engine and wait for all moving parts to come to a complete stop before clearing.
- If engine stalls because of a jam, move throttle control lever to stop position or shut off rocker to "0" if equipped before clearing.

- Do not install, remove, adjust, or service the discharge screen or any other part while the engine is running. Blade contact can occur.
- Do not operate on uneven ground where unit is unstable.
- To avoid a fire hazard, keep leaves, grass, and other combustible materials away from hot engine and muffler.

- Keep children and others away from area of operation.
- Wear approved safety glasses, gloves and ear protection.
- Do not operate on pavement, gravel or other hard surfaces since objects can ricochet and cause injury.

WARNING

DO NOT place wood or branches over 12 cm in diameter into the infeed bin. The blades may get stuck or jammed.

12
cm

BATTERY CONNECTION

Electric Start Model Only

DANGER

WARNING: EMERGENCY STOP

Make sure the emergency stop wire is connected correctly. Failure to do so may result in serious injury or death.

REPLACEMENT BELTS

SAFE OPERATION PRACTICES

Training

- Read this owner's manual carefully in its entirety before attempting to assemble this machine. Read, understand, and follow all instructions on the machine before operation. Be completely familiar with the controls and the proper use of the machine before operating it. Keep this manual in a safe place for future and regular reference and for ordering replacement parts.
- Never allow children to operate the unit. Never allow adults to operate the equipment without proper instruction. Only responsible individuals who are familiar with these rules of safe operation should be allowed to use your unit.
- Keep the area of operation clear of all persons, particularly small children and pets. Stop the engine when they are in the vicinity of the unit. Keep work area clean and clear of branches or obstacles, which could cause you to stumble or fall.
- Keep in mind that the operator or user is responsible for accidents or hazards occurring to other people, their property, and themselves
- Your chipper is a powerful tool, not a plaything. Exercise extreme caution at all times. Your unit has been designed to chip. Do not use it for any other purpose.
- If situations occur which are not covered in this manual, use care and good judgment. Contact your place of purchase for additional assistance.

Preparation

- Thoroughly inspect the area where the equipment is to be used and remove all foreign objects.
- Do not operate the machine without wearing adequate outer garments and safety goggles. Always wear safety glasses or goggles during operation and while performing any adjustment or repair, to protect eyes from foreign objects that may be thrown from the machine. Be sure your glasses or goggles fit properly.
- Avoid loose-fitting clothes and use protective footwear that will improve footing on slippery surfaces. Shirt and slacks that cover the arms and legs and steel-toed shoes are recommended. Secure hair above shoulders. Do not wear loose clothes or jewelry that can be caught in moving parts. Never operate a unit in bare feet, sandals or sneakers. Wear gloves when feeding material into the chipper chute. Be sure your gloves fit properly and do not have loose cuffs or drawstring.
- Warning: Fuel is highly flammable and the vapors are explosive. Take the following precautions.
 - Store fuel and oil in approved containers.
 - Keep away from heat and open flame, and out of the reach of children.
 - Refuel outdoors only and do not smoke while refueling.
 - Check and add fuel before starting the engine. Never remove gas cap or add fuel while the engine is running or when the engine is hot. Allow engine to cool before refueling.
 - If fuel is spilled, do not attempt to start the engine but move the machine away from the area of spillage and avoid creating any source of ignition until fuel vapors have disappeared.
 - Replace all fuel tank and container caps securely.
 - Never store the machine or fuel container inside where there is an open flame or spark, such as a gas hot water heater, space heater, clothes dryer or furnace.
 - To reduce fire hazard, keep engine and muffler free of debris build-up. Clean up fuel and oil spillage. Allow unit to cool at least five minutes before storing.
- Never attempt to make any adjustments while the engine is running.

Operation

- Never place your hands, feet, or any part of your body in the chipper chute, discharge opening, or near or under any moving part while the engine is running. Keep clear of the discharge opening at all times. If it becomes necessary to push material into the chipper chute, use a small diameter stick, NOT YOUR HANDS.
- Keep your face and body back from chipper chute to avoid accidental bounce back of any material.
- The machine should only be operated on a level surface. Never operate your unit on a slippery, wet, muddy, or icy surface.
- Stay alert for hidden hazards or traffic. Do not carry passengers.
- If the cutting mechanism strikes a foreign object or if your machine should start making an unusual noise

or vibration, immediately stop the engine, remove the spark plug wire(s) and wait for all moving parts to come to a complete stop. After the machine has come to a complete stop proceed as follows:

- Inspect for any damage
- Repair or replace any damaged parts before restarting and operating the machine.
- Exercise caution to avoid slipping or falling.
- If the machine should start to vibrate abnormally, immediately stop the engine, remove the spark plug wire(s) and wait for all moving parts to come to a complete stop and inspect for the cause. Vibration is generally a warning sign of trouble.
- Stop the engine when leaving the operating position, and when making any repairs, adjustments and inspections.
- Take all possible precautions as recommended by the manufacturer when leaving the machine unattended. Stop the engine and remove the key if so equipped.
- Before cleaning, repairing, or inspecting, shut off the engine and make certain the flywheel and all moving parts have come to a complete stop. Disconnect the spark plug wire and keep the wire away from spark plug to prevent accidental starting. Do not use flammable solutions to clean air filter.
- Never run this machine in an enclosed area as the exhaust from the engine contains carbon monoxide, which is an odorless, tasteless, and deadly poisonous gas.
- Keep all guards and safety devices in place and operating properly. Do not operate the machine if all safety guards are not in place.
- Do not use the unit with the chipper hopper removed.
- The muffler and engine become hot and can cause a severe burn. Do not touch.
- Keep children and pets away.
 - Tragic accidents can occur if the operator is not alert to the presence of small children
 - Keep children out of the work area and under the watchful eye of a responsible adult other than the operator.
 - Be alert and turn the unit off if a child enters the area.
 - Never allow children to operate the chipper.
- Do not overload or attempt to chip material beyond manufacturers recommendation. Personal injury or damage to the machine could result.
- Never operate the machine at high transport speeds or on hard or slippery surfaces.
- Never allow bystanders near the unit while running.
- Only use accessories approved for this machine by the manufacturer. Read, understand, and follow all the instructions provided with the approved accessory.
- Only operate unit in good daylight. Do not operate unit at night or in dark areas where your vision may be impaired.
- Use extreme caution when reversing or pulling the machine towards you.
- Do not tamper with the engine's governor setting. The governor controls the maximum safe operation speed and protects the engine. Over-speeding the engine is dangerous and will cause damage to the engine and to the other moving parts of the machine. See your authorized dealer for engine governor adjustments.
- Start the engine according to the manufacturers instructions. Keep hands and feet away from inlet and discharge areas.
- Never pick up or carry the machine while the engine is running.
- Do not operate while under the use of alcohol, drugs, or medication. A clear mind is essential for safety.
- Do not allow anyone who is not alert to operate this machine.
- When feeding material into this equipment, be extremely careful that pieces of metal, rocks, or other foreign objects are not included. Personal injury or damage to the machine could result.
- Keep area of discharge clear of people, animals, buildings, glass or anything else that will obstruct clear discharge, cause injury or damage. Wind can also change discharge direction, so be aware.
- Do not allow an accumulation of processed material to build up in the discharge area as this will prevent proper discharge and can result in kick-back from the chipper chute.

- Do not allow any part of the engine, especially around the cooling fans and muffler, to become clogged with processed material, leaves, oil, grease or any other combustible material.
- Do not operate engine if air cleaner or cover over carburetor air-intake is removed, except for adjustment.
- Removal of such parts could create a fire hazard.

Towing

- Obey all state and local regulations when towing on public roads and highways.
- Before towing, be certain the chipper is correctly and securely attached to the towing vehicle and the safety chains are in place. Leave slack in the chains to allow for turning.
- Do not allow anyone to sit or ride on the chipper. This can cause serious injury.
- Stay alert for hidden hazards or traffic. Do not carry passengers.
- Never carry any cargo or wood on your chipper. It may fall off and endanger following vehicles.
- Allow for added length when turning, parking, crossing intersections and in all driving situations.
- Be care when backing up, you. You can easily jackknife your chipper.
- Adjust towing speed for terrain and conditions. Do not exceed 45 MPH when towing.
- Because there is no suspension on the chipper, it will tend to bounce more on rough roads. Be extra cautious when towing over bumpy or rough terrain including railroad crossings.

Maintenance & Storage

- Keep machine, attachments and accessories in safe working condition.
- Check engine mounting bolts and other hardware at frequent intervals for proper tightness. Never operate your chipper in poor mechanical condition or when in need of repair. Be sure all safety guards and shields are in proper position. These safety devices are for your protection.
- Never store machine with fuel in the fuel tank inside a building where ignition sources are present, such as hot water and space heaters, clothes dryers and the like. Allow the engine to cool before storing in any enclosure.
- Always refer to the operator's manual for important details if the machine is to be stored for an extended period.
- If the fuel tank is to be drained, do this outdoors.
- Follow the manufacturer's recommendations for safe loading, unloading and storage of machine.
- If it is necessary for any reason to unclog the feed intake or discharge openings or to inspect or repair the machine where a moving part can come in contact with your body or clothing, shut the machine off, allow all moving parts to come to a complete stop, disconnect the spark plug wire(s) and allow the engine to cool before attempting to unclog, inspect or repair.
- Check the knife mounting screws at frequent intervals for proper tightness. Also visually inspect the knife for wear or damage. Replace the knife with parts that meet original equipment specifications.
- Knives should be checked for sharpness and the bolts attaching them to the flywheel for tightness every 8-10 hours of operation.
- Replace the nylock nuts securing the knife every time you replace the knife.
- Check the gap between the knife and wear plate every time you sharpen or replace the knife, or every 8-10 hours of operation.
- Never tamper with safety devices. Check their proper operation regularly.
- Inspect the belt each time you use the unit. Look for damage, worn areas or tears. Do not use the unit if this condition exists.
- Do not tamper with the engine's governor setting. The governor controls the maximum safe operation speed and protects the engine. Over-speeding the engine is dangerous and will cause damage to the engine and to the other moving parts of the machine. See your authorized dealer for engine governor adjustments.

- Only operate your chipper from the operator zone.
- Know how to turn your chipper off.
- Never move your chipper or leave it unattended with the engine running.
- Follow engine owner's manual for engine maintenance and repair.

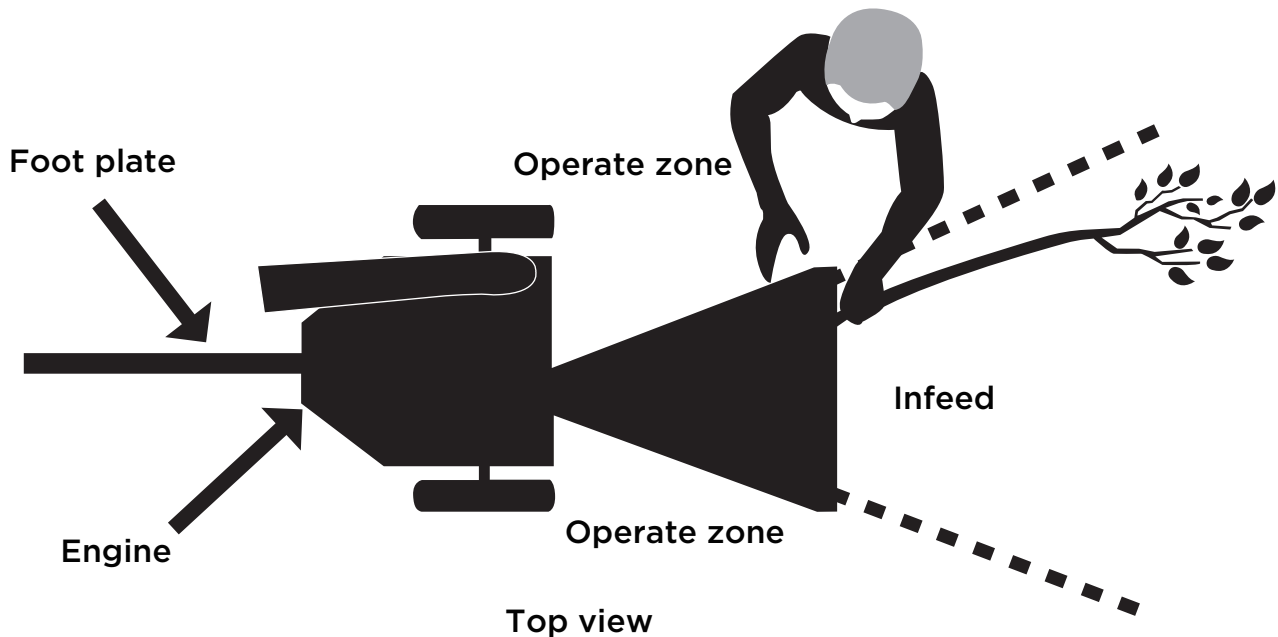

YOUR RESPONSIBILITY

Restrict the use of this power machine to persons who read, understand and follow the warnings and instructions in this manual and on the machine.

**SAVE THESE INSTRUCTIONS FOR
FUTURE REFERENCE**

HAZARD
 This unit is equipped with an internal combustion engine and should not be used on or near any unimproved forest-covered, brush-covered or grass-covered land unless the engine's exhaust system is equipped with a spark arrester applicable local or state laws (if any). If a spark is used, the operator should maintain it in effective meeting arrester working order.

In the State of California, the above is required by law (Section 4442 of the California Public Resources Code). Other states may have similar laws. Federal laws apply on federal lands. A spark arrester for the muffler is available through your Briggs & Stratton servicing dealer

SECTION II - ASSEMBLY INSTRUCTIONS

PACKAGING CONTENTS		
SKID	PARTS BOX	BOLT BAG
Chipper	Chipper Hopper	4 each - 5/16-18 X 3/4" Carriage Bolts
Hitch Arms	Stand	4 each - 5/16-18 Nylock Nut
Hitch Assembly	Glasses	4 each - 5/16 USS Flatwasher
Parts Box	Owner's Manual	2 each - 1/2-13 X 3" HHCS
	Engine Manual	4 each - 1/2-13 X 1 1/4" HHCS
	Bolt Bag	2 each - 1/2-13 Gripco Nut
	Wire Harness	1 each - 3/16 Hair Cotter Pin
	10 each - 14-1/2" Cable Ties	2 each - Hitch Arm Mounting Plates
	Knife Gauge	2 each - Engine Key

Tools required for assembly

- 1/2" Wrench or Socket - 2 required
- 3/4" Wrench or Socket - 2 required

Step 1 - Unpacking and checking contents

- Remove the all items from the crate
- After unpacking the crate, compare the contents with the list above.
- If any parts are missing, please contact the supplier directly.
- Assembly should be done on a clean, level surface.

WOOD CHIPPER ASSEMBLY

Set the shipping crate on a solid flat surface and carefully remove the lid. Use two people and take all parts out of the crate and inspect the components to ensure there are no missing pieces before starting to assemble the log splitter follow steps 1 through 3.

Step 1 - Assembling the feeding hopper

- Assemble feeding hopper(#19) to disc housing(#6) using for hex bolt M8×25 (#77), flat washer 8(#69), and lock nut M8(#70)
- Put the in-feed to frame rubber(#20) between the feeding hopper(#19) to disc housing(#6).

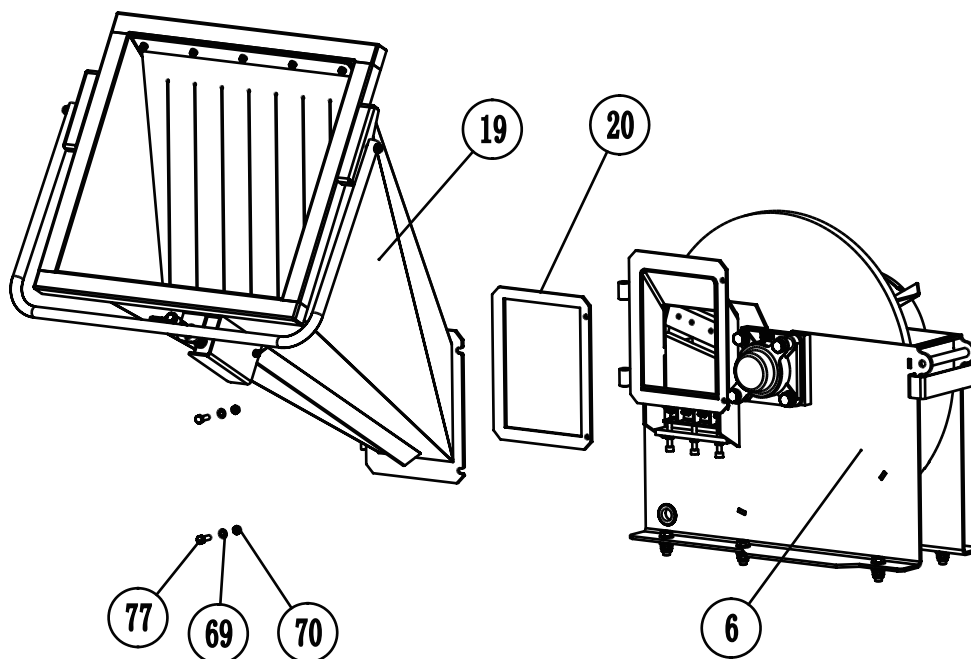

Step 2 - Attaching the hitch arms and trailer hitch assembly

- Attach the coupler (#52) to tow bar(#51), using M12×80 hex bolt(#57),flat washer 12 (#58), and lock nut M12 (#59).
- Attach the tow bar (#51) to chassis(#1), using hex bolt M12×70(#66), flat washer 12(#58), and lock nut M12 (#59).
- Attach the jockey wheel(#53) to tow bar (#51), using M10×60 hex bolt(#54) and flat washer 10 (#55) and hex nut M10(#56).

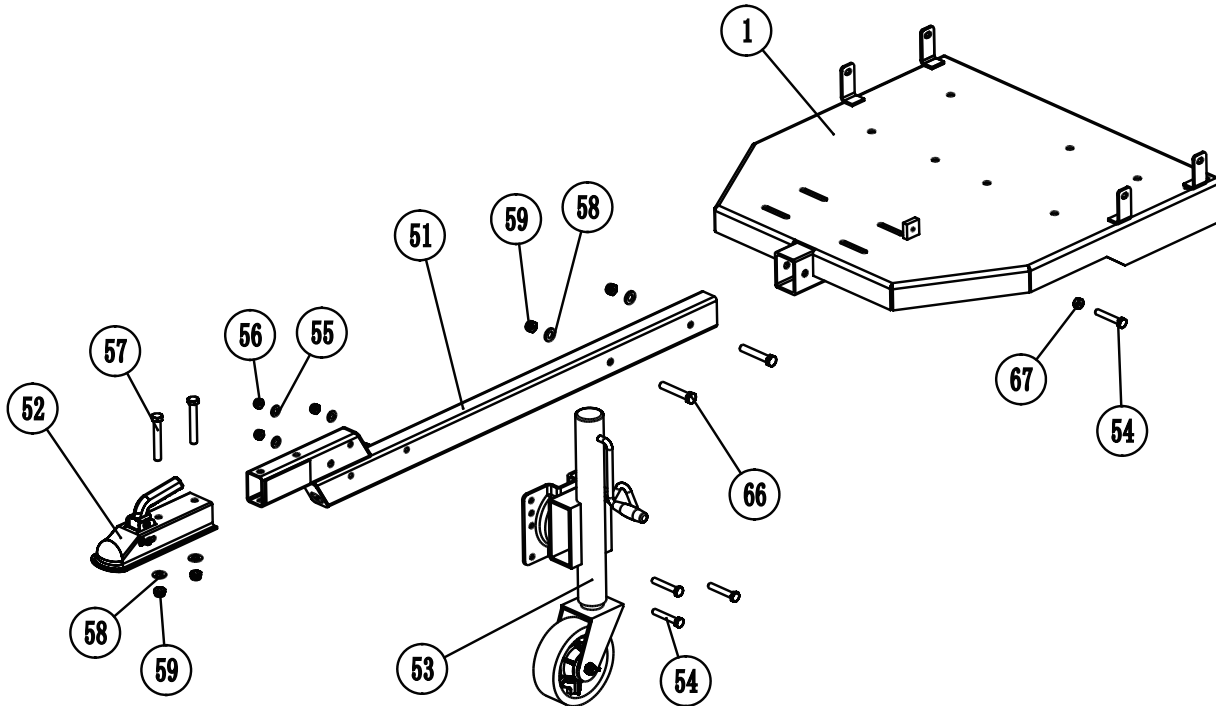

Step 3 - Attaching the tire and tail light frame

- Attach the wheel axis(#2) to chassis(#1), using hex bolt M12×70(#66),flat washer 12(#58), lock nut M12(#59).
- Attach the tire(#3) to wheel axis(#2), lock the hex slotted nut M24×1.5(#61) in place using the split pin 4 ×45(#60), install the dust cover(#4) on the end using rubber hammer.
- Attach the fender(#48) to chassis(#1),using hex bolt M8×20(#68),flat washer 8(#69), and lock nut M8 (#70).

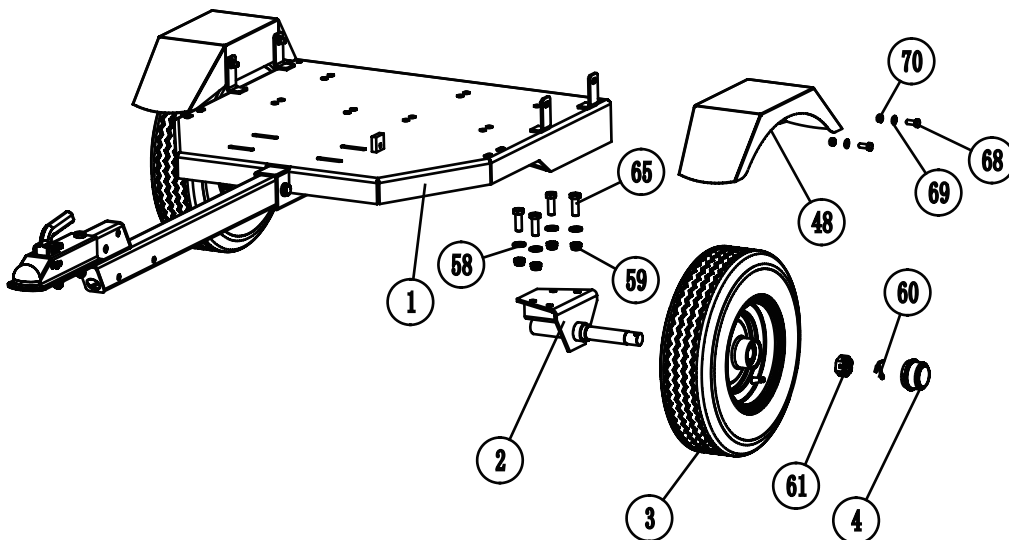

SECTION III - OPERATION

Before starting engine, always check oil level!

Refer to the engine owner's manual for further details regarding operation and maintenance of the engine.

NOTE: engine is shipped without oil! Fill crankcase with oil before starting engine. Be very careful not to allow dirt to enter the engine when checking or adding oil or Fuel.

NOTE: if you start the engine without oil, the engine will be damaged beyond repair and will not be covered under warranty.

Oil

- Use a high quality detergent oil classified "For Service SF, SG, SH, SJ" or higher.
- Do not use special additives.
- Choose a viscosity according to the following table.

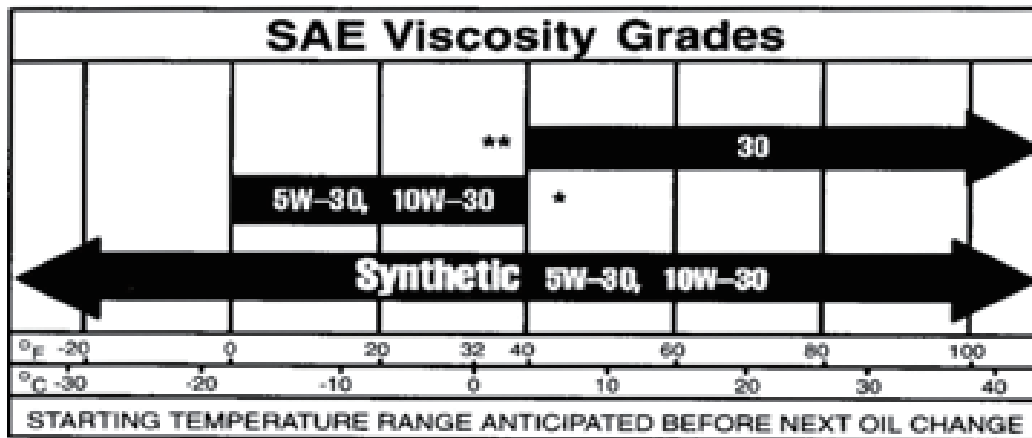

⚠ CAUTION

Air cooled engines run hotter than automotive engines. The use of non-synthetic multi-viscosity oils (5W-30, 10W-30, etc.) in temperatures above 40 deg. F (4 deg. C) will result in higher than normal oil consumption. When using a multi-viscosity oil, check oil level more frequently.

⚠ CAUTION

SAE 30 oil, if used below 40 deg. F (4 deg. C), will result in hard starting and possible engine bore damage due to inadequate lubrication.

CHECKING AND ADDING OIL

- Check oil level before starting the engine.
- Check level daily, or after every eight hours.
- Keep oil level at FULL.
- Do not overfill.

Oil filling procedure:

First add 1 quart. Start and run engine at idle for 30 seconds. Shut engine off and wait 30 seconds. Then add more oil slowly to bring level to Full mark on dipstick.

Oil checking procedure:

Before starting engine, check oil level.

- Place engine level. Clean around oil fill and dipstick.
- Remove dipstick and wipe clean with cloth.
- Push dipstick back in and remove to check oil level.
- Remove oil fill cap. Pour oil slowly.
- Fill to Full line on dipstick - recheck.
- Replace dipstick firmly.

FUEL

- Use clean, fresh, regular unleaded gasoline with a minimum of 85 octane. Fresh fuel prevents gum from forming in the fuel system or on essential carburetor parts. Purchase fuel in quantity that can be used within 30 days.
- Do not use gasoline which contains Methanol.
- Do not mix oil with gasoline.

⚠ CAUTION

Some fuels, called oxygenated or reformulated gasoline, are gasoline blended with alcohols or ethers. Excessive amounts of these blends can damage the fuel system or cause performance problems. If any undesirable operating symptoms occur, use gasoline with a lower percentage of alcohol or ether.

Adding fuel

- Fill tank outdoors or in a well-ventilated area, away from sparks, open flames, pilot lights, heat and other ignition sources
- If fuel spills, wait until it evaporates before starting engine.
- Turn engine OFF and let engine cool at least 2 minutes before removing gas cap.
- Remove cap. Fill tank to approximately 1-½ inches below top of neck to allow for fuel expansion. Be careful not to overfill.
- Replace cap before starting.

STARTING AND STOPPING

Starting and operating tips

- Store and fuel equipment in level position.
- Use fresh fuel.
- Use correct type of oil for expected starting temperature.
- Remove external equipment/engine loads.
- Periodically remove any debris buildup from the machine.
- After engine has started, let it warm up several seconds to several minutes, depending on outside temperature.
- For maximum performance and life, operate engine with choke in RUN and throttle in FAST.

To start engine

- Check oil level.
- Open fuel shut-off valve.
- Move choke control to CHOKE position.
- Move throttle to FAST position. Operate engine with throttle in FAST.
- Insert key and turn to START. CAUTION: to prolong starter life, use short starting cycles, 5 seconds maximum, then wait one minute.
- Let engine warm up. Slowly adjust choke control toward RUN position. Wait until engine runs smoothly before each choke adjustment.

To stop engine

- Move throttle to SLOW.
- Turn key to off. Remove key and store out of reach of children.
- Close fuel shut-off valve.

⚠ CAUTION

Do not stop engine by moving choke control to CHOKE. Backfire, fire or engine damage could occur.

OPERATION NOTES

- At engine start-up, the engine of your chipper operates under no load until approximately 1200-1400 RPMs at which speed the centrifugal clutch engages and begins driving the rotor.
- Proper rotor speed is 2400 RPM +/- 200 RPM.
- When viewed from the operator zone, the flywheel turns in a clockwise direction. This rotation pulls branches into the chipper.
- Always wear protective gloves and safety glasses during operation of the chipper.
- If it becomes necessary to push material into the chipper hopper, only use a wood stick, never your hands or anything steel.
- Never assume you know where the knife is. You don't know where it is. Always keep hands out of the chipper hopper.
- Keep area of discharge clear of people, animals, buildings, glass or anything else that will obstruct clear discharge, cause injury or damage. Wind can also change discharge direction, so be aware

SECTION IV - CHIPPING

This chipper was designed for chipping limbs or branches. Never use this machine for any other purpose as it could cause serious injury.

Safety first

- Always wear protective gloves and safety glasses during operation of the chipper.
- Never allow your hands or any part of your body or clothing inside the chipper hopper or discharge area of the chipper.
- Keep all protective guards and warning labels on the machine and in good working condition.
- Always stand clear of the discharge area when the chipper is running.
- Keep your face and body back from the chipper hopper to avoid being struck by any material that may bounce back.
- Keep proper balance and footing while operating the chipper.
- If it becomes necessary to push material into the chipper hopper, only use a wood stick, never your hands or anything steel.
- Never assume you know where the chipper knife is. You do not know where it is.
- Keep area of discharge clear of people, animals, buildings, glass or anything else that will obstruct clear discharge, cause injury or damage. Wind can also change discharge direction, so be aware.
- Always keep hands out of the chipper hopper.
- Never operate the chipper without the chipper hopper in place.
- Do not transport the chipper while the engine is running.
- Do not refuel the engine while it is hot, warm, or running.
- Do not cover the chipper while the muffler is still hot.

Processing limbs or branches

- Your chipper can process dry or green material.
- Remove side limbs, branches or twigs from main branch.
- Feed branch into chipper hopper.
- Keep branch at same angle as chipper hopper.
- As the branch becomes short and is inside the chipper hopper, finish processing it by pushing it into the chipper with the next branch.
- If branches are 2" or larger in diameter, feed only one branch at a time into the chipper.
- If branches are smaller than 2", more than one at a time can be fed into the chipper.
- Green branches process quicker and easier than dry branches.
- Soft wood processes easier than hard wood.
- When chipping branches, sometimes a tail will be left at the end of the branch (usually green wood) that will increase in length as you chip. To avoid this, rotate or twist the branch as you feed it into the chute.
- Rotating the branch as you feed it into the machine will improve chipping performance.

- Use common sense when using your chipper.
- Learn to recognize the change in the sound of your machine when it is overloaded.
- Become familiar with successful operating conditions and avoid those that can overload and damage the machine.
- If the machine becomes jammed by overloading or any other cause, stop the machine immediately.
- If you jam the machine and do not stop the engine, it can:
 - Burn the belt
 - Ruin the clutch
 - This damage can be costly and it may not be covered under warranty. For this reason, it is important that you immediately shut off the machine if it becomes jammed.
- Only your operator experience will tell you how fast to feed limbs.
- Check to see that the flywheel will turn freely before you start the chipper.
- Visually check chipper knife for damage each time you use your chipper.
- Check knife condition, wear plate condition, gap setting and the nuts and bolts that hold the knife in place for tightness every 8-10 hours of operation
- Do not allow chips to build up within 3” of discharge chute opening. Move chipper or pile as needed. Failure to do this could result in unnecessary jamming of the machine
- To move pile of processed material, use spade, rake, or long handle tool. Never use your hands or feet!

To free a jammed flywheel

- Stop the engine.
- Remove the spark plug wire and keep away from the spark plug.
- Disconnect battery at negative terminal (if so equipped).
- Remove any material left in the chipper hopper.
- Remove the deflector.

NOTE: Never pry against the scroll weldment when removing the deflector or at any other time. This will cause damage to the machine.

- Check to see if deflector is clogged. If it is, clear with a branch.
- With a wooden stick, loosen and remove any material left in the chipping chamber.
- Reinstall the deflector.
- Reconnect the spark plug wire and battery (if so equipped).
- Start machine and let material in chipping chamber discharge through deflector.
- If chamber doesn't clear and the flywheel is still jammed, repeat above process.
- Be certain chipping chamber is clear before trying to process more material into the chipper.

SECTION V - MAINTENANCE AND STORAGE

IMPORTANT: The knife should be checked for sharpness and the nuts and bolts attaching them to the flywheel for tightness every 8-10 hours of operation.

IMPORTANT: Every time you perform maintenance or any kind of service or check on the knife, be sure to check the gap between the knife and wear plate for proper setting.

NOTE: A knife gauge has been provided with your machine. It is 1/16th" thick and should be used to set the correct gap between the knife and wear plate.

If the cutting mechanism strikes any foreign object or if your machine should start making an unusual noise or is vibrating, stop the engine, disconnect spark plug wires from the spark plugs. Allow the engine to cool before you;

- Inspect and examine for obvious damage.
 - Check for loose parts, bolts, and nuts.
 - When not in use, your chipper should be stored out of the reach of children. Be sure there are no gasoline
1. 1. fumes in the storage area. For long periods of storage (over winter), refer to the engine owner's manual.
 2. 2. After every 8 hours of operation, lubricate the chipper side and drive side bearings. To do this, wipe all dirt, etc., from the grease fittings with a clean cloth, then apply no more than 3 shots of quality general-purpose grease with a hand-pumped grease gun. Over lubrication can also damage bearings. Also, check the bearing collar set screws regularly to be sure they are tight. If they are loose, reset them with Loctite 243, obtainable at any hardware store.
 3. 3. You will find information included referring to operation and maintenance of the chipper engine. Look it over carefully. **BE CERTAIN TO SERVICE THE ENGINE BEFORE YOU START IT.**
 4. 4. When the steel chipping knife needs replacing or sharpening, refer to the section on removal, sharpening and re-installation.
 5. 5. Care must be exercised when sharpening the knife to maintain the correct bevel and a straight edge. Refer to sharpening directions. When you install a knife, the clearance between the knife and wear plate must be checked and set. This clearance or gap should be set to 1/16" .
 6. 6. To adjust this clearance, loosen the four nuts and bolts holding the wear plate in place. The wear plate can be slid up or down (in or out) to achieve the correct gap setting.
 7. 7. Take the knife gauge and slide between the knife and wear plate. If the gap is set correctly, the knife gauge will lightly touch both the knife and wear plate. If the gap is too small, you will not be able to get the gauge between the knife and wear plate. If the gap is too large, there will be excess room between knife gauge, knife and wear plate. Tighten the nuts and bolts when the wear plate is in the correct position. Be certain the flywheel rotates without hitting anything before starting the chipper.
 8. 8. If the gap between the wear plate and the knife is not set correctly, you will have excessive vibration when chipping and the blade will seem to be dull. This should be checked every 8-10 hours of operation. If at any time it becomes necessary to disassemble the chipper for repairs, the chipper disk must be re-installed in exactly the same position on the rotor shaft.

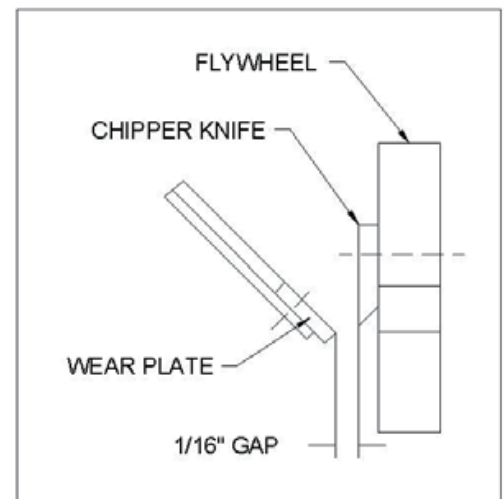

NOTE: PROPER GAP SETTING IS CRITICAL TO THE PROPER OPERATION OF YOUR MACHINE.

REMOVAL, SHARPENING AND RE-INSTALLATION OF CHIPPER KNIFE

How to remove the knife

- Stop the engine.
- Open the upper disk housing.
- Rotate the chipper disk until the four countersunk screws and lock nuts attaching the knife to the flywheel are visible through the access doors.
- Remove all four screws and nuts.

Knife sharpening

- You should never attempt to sharpen the chipper knife (or knives) freehand.
- It is extremely important that the 45 degree angle be maintained consistently for proper performance.
- The chipper knife should be taken to a machine shop for proper sharpening.
- Excessive heat generated during the sharpening process will damage knives and weaken the metal. Be sure the knife is not overheated.

Knife information

- The chipper knife should be checked routinely for sharpness.
- Using a dull knife will decrease performance and cause excessive vibration that will cause damage to the chipper.
- How many times a knife can be sharpened is determined by how much material needs to be taken off to sharpen or to compensate for dents or gouges.
- A new chipper knife has 18mm measurement between the short side bevel edge and the knife mounting holes.

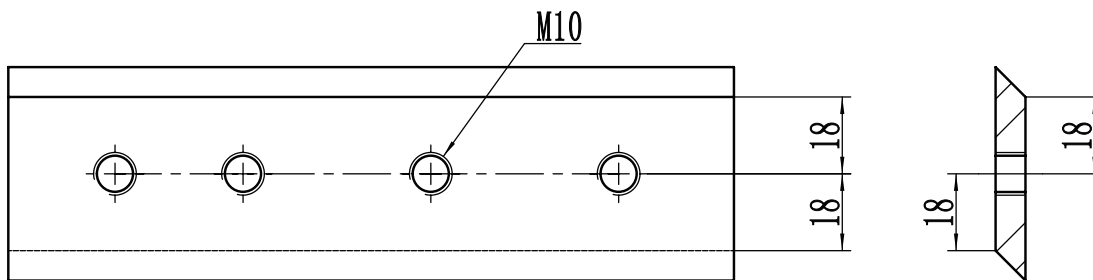

- The knife should never be sharpened to the extent that more than 2.5mm is taken off this measurement.
- Once this measurement is below 16.5mm the knife should be replaced.
- If you are unable to remove dents or gouges with these guidelines, replace the knife.

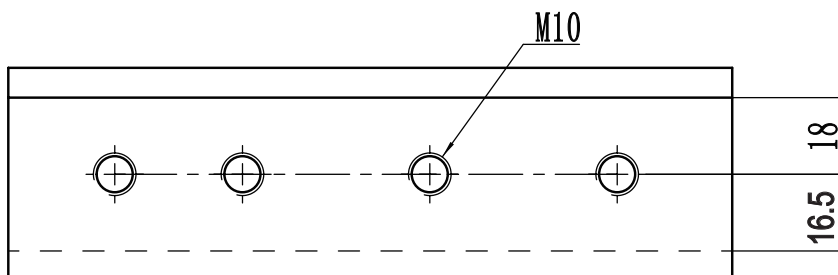

Knife installation

- Clean chipper disk where knife is going to be attached.
- Visually inspect the chipper disk slot and knife mounting area and be sure they are clean and that the knife will be able to mount flush against the chipper disk.
- Visually inspect and clean the knife.
- Hand tighten the knife to the chipper disk with bolts and nylock locking nuts. If you are installing a new knife, use the new hardware that comes with the knife when attaching it to the chipper disk.
- Tighten the center nut and bolt.
- Tighten the outer nut and bolt.
- Tighten the inner nut and bolt.
- Double check all four for tightness one more time.

Wear plate

- The wear plate should have a square, 90-degree edge, and be free of dents or gouges.
- The wear plate can be sharpened by hand, but as with the knife, do not overheat during the sharpening process. This will change the characteristics of the steel and it should be replaced.
- Check the gap between the knife and wear plate every time any adjustments are done to either piece, or every 8-10 hours of operation.

After any blade or wear plate maintenance or adjustment, rotate the chipper disk by hand. Watch and listen carefully for any unusual noises, clicking or vibration. If any of these are detected, inspect the machine for damage, repair or replace any damaged parts and check for any loose parts and retighten.

KNIVES MUST BE CHECKED AND MAINTAINED!

KNIVES MUST BE SHARP!

BE SURE TO REINSTALL THE KNIFE CORRECTLY AND DOUBLE CHECK FOR TIGHTNESS!

Changing oil

- Your chipper is equipped with an oil drain valve to make changing the oil easy.
- The valve is located on the engine, on the towing side of the machine.
- Place engine level.
- Disconnect spark plug wires and keep it away from spark plugs. Disconnect battery (if equipped with electric starter) at negative terminal.
- With engine OFF but still warm open oil drain valve and drain oil into appropriate receptacle.
- Note: To open valve, push in and turn counterclockwise.
- Close oil drain valve.
- Remove oil fill cap if equipped).
- Fill to FULL mark on dipstick with new oil. Do not overfill.
- Note: Engine holds approximately 1-1/2 quarts (48 ounces) when changing oil and filter.
- Replace oil fill cap and dipstick

INSTRUCTIONS FOR ADJUSTING OR REPLACING BELT

Belt adjustment

The belt on your chipper should deflect 3/8" under three pounds of pressure as shown in figure 1 below. If it doesn't, adjust per the following directions.

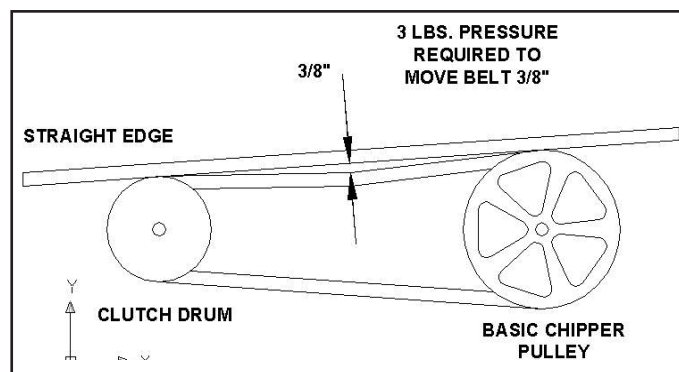

- Remove belt guard.
- Loosen engine bolts.
- Tighten or loosen the nut on the belt tensioner until you have the correct tension as shown in figure 1.
- Retighten engine bolts.
- Check alignment of the clutch (item #47) with the drive pulley (item #22) by placing a straightedge across both faces as shown in figure 2. If adjustment is necessary, correct alignment by moving rotor pulley in or out on the rotor shaft. Do not make adjustment by moving the clutch on the engine shaft.
- Replace belt guard

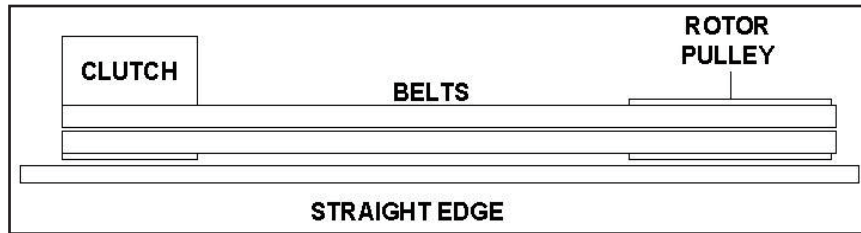

Belt replacement

- To replace the belt, follow the above belt adjustment directions.
- After you have loosened the engine bolts, remove the old belts and replace it with new belts. Always replace both belts as they come in a matched set.
- This is required for proper operation.
- Set belt tension and alignment per above directions.

NOTE: Check and re-tighten belts after initial break-in period, one hour of use.

CENTRIFUGAL CLUTCH TECH TIPS

The shoes and springs on the clutch are normal wear items. If you notice decreased performance of the clutch they should be checked and replaced if necessary.

The clutch on your machine is designed for rugged, dependable service, however, it is important to understand the limitations of a clutch. A clutch is designed to provide load free starting of the engine, and slippage under excessive overloading of the driven application. These features help protect the engine from damages such as broken crankshafts and starters.

The clutch obtains its power from engine RPM's. The lower the engagement speed, and the higher the maintained engine speed, the more torque the clutch can transfer to the driven unit. Do not operate at less than full RPM's.

- At engine start-up, the engine of your chipper operates under no load until approximately 1000-1200 RPM'S at which speed the centrifugal clutch engages and begins driving the rotor.
- Proper rotor speed is 2400 RPM +/- 200 RPM.
- Do not tamper with the engine's governor setting. The governor controls the maximum safe operation speed and protects the engine. Over-speeding the engine is dangerous and will cause damage to the engine and to the other moving parts of the machine.
- See your authorized dealer for engine governor adjustments.
- Become familiar with successful operating conditions and avoid those that can overload and damage the machine.
- Do not overload or attempt to chip material beyond manufacturers recommendation.
- Personal injury or damage to the machine could result.
- Learn to recognize the sound of the machine when it is overloaded. If the machine becomes jammed by overloading or any other cause, stop the machine immediately.
- If you jam the machine and do not stop the engine, it can:
 - Burn the belt.
 - Ruin the clutch.
- Only your operator experience will tell you how fast you can successfully feed limbs into the machine.
- Clutch damage can be costly and it may not be covered under warranty. For this reason, it is important that you immediately shut off the machine if it becomes jammed.

CLUTCH MAINTENANCE

The centrifugal clutch on this machine is permanently lubricated and does not require oil or grease. If, after long periods of use, the drum wobbles excessively, replace the drum assembly. Always replace shoes and springs in sets. Whenever shoes are changed, replace all springs.

Clutch removal

1. Remove clutch from shaft by removing bolt and washers.
2. Slide clutch off shaft.
3. Remove key from keyway.

Disassembly of existing clutch

1. Remove retainer ring and slide off drum assembly.
2. Unhook one spring from its shoe. Use tape wrapped pliers to avoid nicking spring.
3. Carefully note position of shoes. Remove shoes from hub.

Reassemble

1. Locate shoes correctly on hub for rotation required.
2. Place one end of each spring over a shoe pin, stretch spring just enough to clear pin on the other shoe. Use tape wrapped pliers to avoid nicking spring. Avoid over stretching that may damage spring. Repeat for all shoes.
3. Replace washer on hub shaft.
4. Reassemble drum to hub, secure with retaining ring.
5. Locate key in keyway of hub.
6. Slide clutch onto crankshaft, then washers.
7. Secure hub by tightening cap screw and allen head set screws.

Installation of a new clutch

1. Clean shaft and remove any burrs.
2. Apply anti-seize compound to the shaft.
3. Place key in keyway on shaft.
4. Slide clutch onto shaft, secure with bolt, flatwasher and lockwasher.
5. Tighten two allen head set screws.

TROUBLESHOOTING

SYMPTOM	PROBLEM	CORRECTION
Clutch overheats. Belt burns. Flywheel won't turn.	Clutch is slipping or flywheel is jammed or stopped.	Immediately stop engine. Remove spark plug wires. Turn flywheel by hand to be sure it turns freely Check belt tension. Clear chipper chamber.
Chipping action seems too slow or flywheel stalling.	Engine speed is too slow. Belts are slipping.	<ul style="list-style-type: none">• Run engine at full throttle.• Check for loose or missing belt & tighten.
When chipping, log seems to vibrate excessively & "hammers" hands.	Knife is dull. Gap between knife & wear plate is too great.	<ul style="list-style-type: none">• Remove knife & sharpen -be sure to maintain same bevel of 45 degrees.• Adjust gap as per instructions.
Chipper knife is hitting wear plate.	The gap between the knife and wear plate is set incorrectly.	<ul style="list-style-type: none">• Adjust gap per directions in the front of this section.
Engine runs but flywheel doesn't rotate.	Inner shoes of clutch worn. Retaining springs weak or broken. Loose drive belt.	<ul style="list-style-type: none">• Replace worn or broken clutch parts.• Check belt tension.• Clear chipper chamber.

LUBRICATION AND MAINTENANCE

OPERATION HOURS	PROCEDURE	COMMENTS
Break in	<ul style="list-style-type: none"> • Change engine oil and filter after first five hours. • Check belt tension. • Check all nuts and bolts for tightness. 	<ul style="list-style-type: none"> • Follow oil recommendations per the engine & owner's manual. • Adjust per directions. • Tighten if necessary.
8 hours	<ul style="list-style-type: none"> • Check engine oil. • Check chipper knife for sharpness. • Check knife and wear plate gap. • Clean air filter. • Grease bearings in basic chipper. * 	<ul style="list-style-type: none"> • Per recommendations, do not overfill. • See knife information. • See gap setting information. • Per engine recommendations. • Use high quality multipurpose lithium grease.
40 hours.	<ul style="list-style-type: none"> • Change engine oil. ** • Check tire pressure. • Remove and sharpen or replace chipper knife. • Sharpen wear plate. 	<ul style="list-style-type: none"> • Per recommendations, do not overfill. • Add or adjust as required. • See knife information. • See wear plate information.
100 hours	<ul style="list-style-type: none"> • Replace belt. • Change engine oil. 	<ul style="list-style-type: none"> • Order replacement belts. • Per recommendations, do not overfill.
200 hours	<ul style="list-style-type: none"> • Change engine oil filter. • Clean and adjust, or replace spark plugs. 	<ul style="list-style-type: none"> • Per recommendations in engine manual. • Per recommendations in engine manual.

* No more than 3 shots from a hand grease gun. Do not over-grease as this may damage the bearing.

** Lubrication schedule may vary depending on working environment. Overly dirty and dusty situations will require more frequent oil changes to protect the engine.

PARTS LISTS

No.	Description	Part#	Qty	No.	Description	Part #	Qty.
1	Chassis	101.101B.008	1	48	Fender	101.101B.048	2
2	Wheel axis	101.101B.009	2	49	Engine	101.101B.049	1
3	Tire 4.8-8	101.101B.004	2	50	Safety chain	101.101B.050	2
4	Dust cover	101.101B.010	2	51	Tow bar	101.101B.051	1
5	Anvil mounting plate	101.101B.011	1	52	Coupler	101.101B.052	1
6	Disc housing	101.101B.012	1	53	Jockey wheel	101.101B.053	1
7	Protective ring	101.101B.013	2	54	Hex bolt M10x60	101.101B.054	4
8	Emergency Shutoff	101.101B.005	2	55	Flat washer 10	101.101B.055	19
9	Limit switch cover	101.101B.014	1	56	Lock nut M10	101.101B.056	10
10	Buckle	101.101B.015	1	57	Hex bolt M12x80	101.101B.057	2
11	Fixed Blade	101.101B.001	1	58	Flat washer 12	101.101B.058	30
12	Spring	101.101B.016	1	59	Lock nut M12	101.101B.059	22
13	Emergency stop bar	101.101B.017	1	60	Split pin 4x45	101.101B.060	2
14	Stop bar support	101.101B.018	2	61	Hex slotted nut M24x1.5	101.101B.061	2
15	Switch cover	101.101B.019	1	62	Spring washer 10	101.101B.062	14
16	Switch mounting plate	101.101B.020	1	63	Flat washer 14	101.101B.063	10
17	Rubber mounting plate	101.101B.021	1	64	Carriage bolt M10x45	101.101B.064	4
18	Rubber chip baffle	101.101B.022	1	65	Hex bolt M12x30	101.101B.065	15
19	Feeding hopper	101.101B.023	1	66	Hex bolt M12x70	101.101B.066	2
20	In-feed to frame rubber	101.101B.024	1	67	Hex bolt M10	101.101B.067	1
21	Flywheel Blade	101.101B.002	2	68	Hex bolt M8x20	101.101B.068	14
22	Bearing cover	101.101B.025	1	69	Flat washer 8	101.101B.069	24
23	Locating bush	101.101B.026	2	70	Lock nut M8	101.101B.070	14
24	UCFU208 bearing	101.101B.006	2	71	Spring washer 8	101.101B.071	10
25	Bearing mounting plate	101.101B.027	2	72	Hex bolt M10x20	101.101B.072	8
26	Chipper disk	101.101B.028	1	73	Hex socket screw M8x45	101.101B.073	3
27	Locating bush	101.101B.029	1	74	Hex nut M8	101.101B.074	3
28	Flat key	101.101B.030	1	75	Hex bolt M14x45	101.101B.075	6
29	Pulley	101.101B.031	1	76	Spring washer 14	101.101B.076	8
30	Pulley gasket	101.101B.032	1	77	Hex bolt M8x25	101.101B.077	2
31	Disk cover	101.101B.033	1	78	Hex bolt M5x12	101.101B.078	8
32	Junction plate 1	101.101B.034	1	79	Spring washer 5	101.101B.079	8
33	Rotating plate	101.101B.035	1	80	Flat washer 5	101.101B.080	8
34	Junction plate 2	101.101B.036	1	81	Hex bolt M6x50	101.101B.081	4
35	Handle	101.101B.037	1	82	Flat washer 6	101.101B.082	21
36	Handle shaft	101.101B.038	1	83	Lock nut M6	101.101B.083	15
37	Spring	101.101B.039	1	84	Hex bolt M6x16	101.101B.084	4
38	Handle support	101.101B.040	1	85	Spring washer 6	101.101B.085	4
39	Discharge chute	101.101B.041	1	86	Hex bolt M8x16	101.101B.086	4
40	Deflector	101.101B.042	1	87	Hex bolt M8x20	101.101B.087	11
41	Star bolt M8x20	101.101B.043	2	88	Hex bolt M6x25	101.101B.088	2
42	Belt cover	101.101B.044	1	89	Hex bolt M12x165	101.101B.089	1
43	V-belt 17x900	101.101B.003	2	90	Hex bolt M10x30	101.101B.090	1
44	Clutch gasket	101.101B.045	1	91	Engine shaft bolt	101.101B.091	1
45	Clutch	101.101B.007	1	92	Hex bolt M10x70	101.101B.092	1
46	Engine flat key	101.101B.046	1	93	Hex bolt M10x45	101.101B.093	1
47	Locating bush	101.101B.047	1	94	Hex bolt M14x65	101.101B.094	2

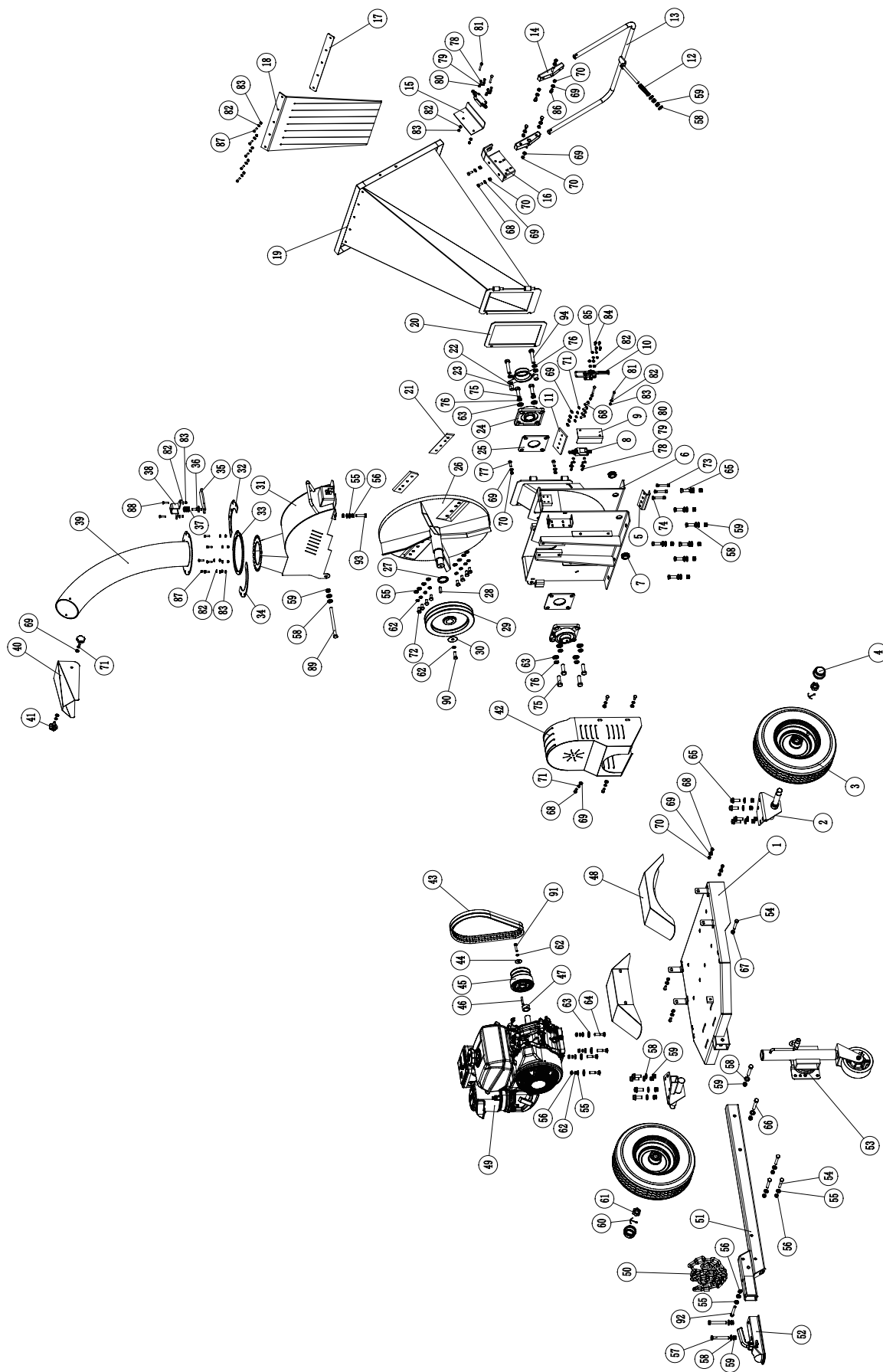



BRABEREQ.COM
WGSALES@BRABEREQ.COM

PHONE: 604-850-7770
FAX: 604-850-7774
TOLL FREE PHONE: 1-877-588-3311
TOLL FREE FAX: 1-800-665-7334