

Technical sheet :

# **TMT 55 HT**

---



	Technical characteristics		Metric
1.1	Manufacturer		Manitou
1.2.1	Reach out equipment		Telescopic boom
1.3	Power source		Diesel
1.4	Operator type		Seated
1.5	Max. capacity	Q	2500 kg
	<b>Weight</b>		
2.1	Service weight		2660 kg
	<b>Wheels</b>		
3.2	Dimensions of front wheels		31 x 15,5 - 15"
3.3	Dimensions of rear wheels		31 x 15,5 - 15"
3.5	Number of front wheels / rear wheels		3 / 1
3.5.2	Drive wheels (front / rear)		2 / 1
	<b>Dimensions</b>		
4.4	Max. lifting height	h3	3430 mm
4.5	Height telescopic boom extended	h4	3915 mm
4.20	Length to face of forks	l2	2.85 m
4.21	Overall width	b1	2.57 m
4.22	Forks section / width / length	s / e / l	44 mm x 102 mm / 1219 mm
4.28	Max. Reach	l4	1310 mm
4.35	Turning radius	Wa	2.74 m
	<b>Performances</b>		
5.1	Travel speed (laden)		11 km/h
5.10	Service brake		Hydrostatic
5.11	Transmission type		Hydrostatic
	<b>Engine</b>		
7.1	Engine brand / norm		Kubota - Tier 4 final
7.2	Engine power according to ISO 1585		37 kW
7.3	Rated speed		2700 rpm
7.4	Capacity of cylinders		2434 cm³
	<b>Miscellaneous</b>		
8.2	Working hydraulic pressure for attachments		245 Bar
8.3	Oil flow rate for attachments		46 l/min

## Dimensional drawing

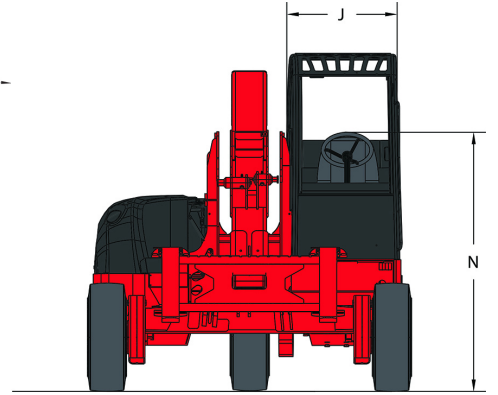
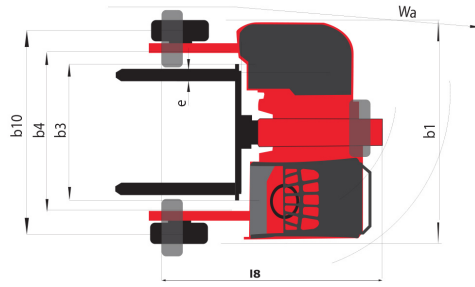
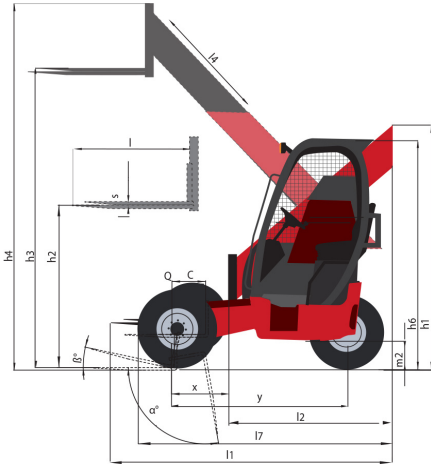

# Load chart

Machine on stabilizers with forks Metric

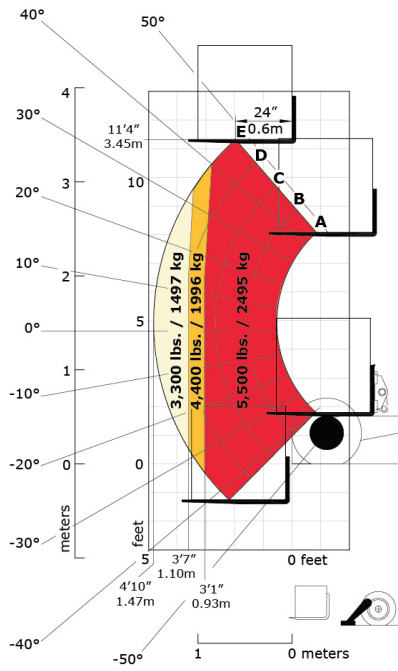

Machine on tyres with forks Metric

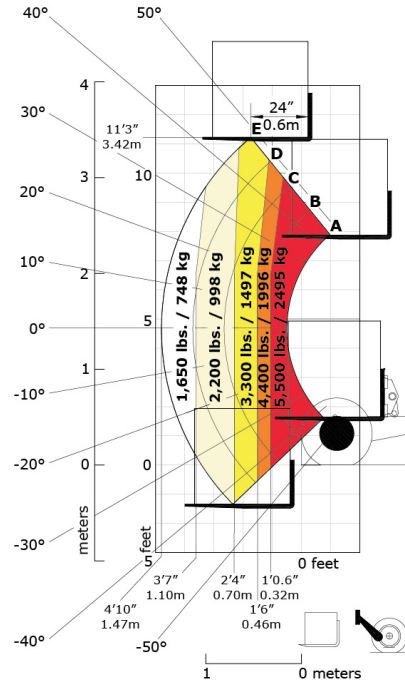

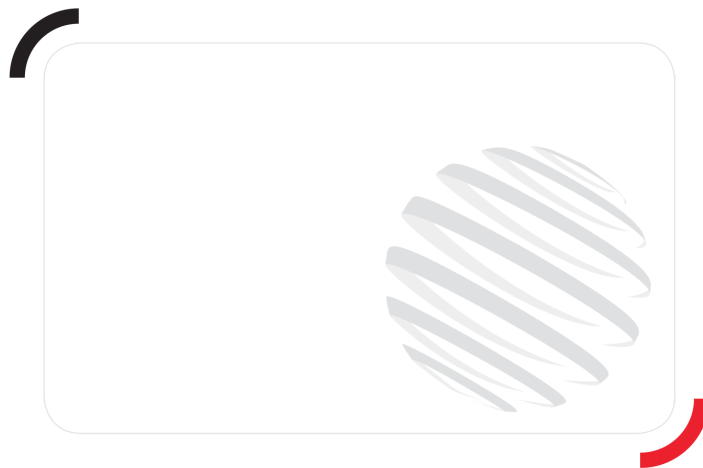

Siège Social

430 rue de l'Aubinière - 44150 Ancenis Cedex - France

Tel: +33(0)2 40 09 10 11 - Fax: +33 (0)2 40 09 10 97

[www.manitou.com](http://www.manitou.com)



This brochure describes versions and configuration options for Manitou products which may be fitted with different equipment. The equipment described in this brochure may be standard, optional or not available depending on version. Manitou reserves the right to change the specifications shown and described at any time and without prior warning. The manufacturer is not liable for the specifications given. For more information, contact your Manitou dealer. Non-contractual document. Product descriptions may differ from actual products. List of specifications is not comprehensive. The logos and visual identity of the company are the property of Manitou and may not be used without authorisation. All rights reserved. The photos and diagrams contained in this brochure are provided for information only.

MANITOU BF SA - Limited company with board of directors - Share capital: 39,668,399 euros - 857 802 508 RCS Nantes