

Technical sheet :

# **MC 25-4 ST5**

---



Technical characteristics			Metric
1.1	Manufacturer		Manitou
1.2	Model Name		MC 25-4 ST5
1.3	Power source		Diesel
1.4	Operator type		Seated
1.5	Max. capacity	Q	2500 kg
1.6	Load centre of gravity	c	500 mm
1.8	Load distance, centre of drive axle to fork	x	621 mm
1.9	Wheelbase	y	1900 mm
Weight			
2.1	Service weight		4290 kg
2.2	Weight on front axle (laden) / rear axle (laden)		5970 kg / 820 kg
2.3	Weight on front axle (Unladen) / rear axle (Unladen)		1780 kg / 2510 kg
Wheels			
3.1	Tyres type		Pneumatic
3.2	Dimensions of front wheels		12,5/80-18/12 SL R4
3.3	Dimensions of rear wheels		27x10-12 SKS
3.5	Number of front wheels / rear wheels		2 / 2
3.5.2	Number of drive wheels		4
3.6	Front wheel gauge	b10	1159 mm
3.7	Rear wheel gauge	b11	1176 mm
Dimensions			
4.1	Tilt of Mast Forward (deg) / Backward (deg)	$\alpha / \beta$	12 / 10
4.7	Height of overhead guard (cabin)	h6	2155 mm
4.7	Overall height of low overhead guard (Buggie version)	h6*	1990 mm
4.8	Seat height/stand height	h7	1094 mm
4.19	Overall length	l1	4195 mm
4.20	Length to face of forks	l2	3045 mm
4.21	Overall width	b1	1450 mm
4.22	Forks section / width / length	s / e / l	40 mm x 100 mm / 1200 mm
4.23	Fork carriage ISO 2328 (class/form) A/B		FEM 2A
4.24	Fork carriage width	b3	1260 mm
4.31	Ground clearance below mast	m1	300 mm
4.32	Ground clearance at centre of wheelbase	m2	310 mm
4.33	Aisle Width for pallets 1000 x 1200 crossways	Ast	5426 mm
4.35	Turning radius	Wa	3405 m
Performances			
5.1	Travel speed (laden / unladen)		12 km/h / 24.50 km/h
5.2	Lifting speed (laden / unladen)		0.47 m/s / 0.46 m/s
5.3	Lowering speed (laden / unladen)		0.50 m/s / 0.30 m/s
5.5	Drawbar pull (Laden)		3100 daN
5.7	Gradeability (laden)		51 %
5.10	Service brake		Hydraulic brakes by loss of pressure
Engine			
7.1	Engine brand / model / norm		Kubota / D1803 CRT E5B / Stage V
7.2	Engine power according to ISO 1585		37 kW
7.3	Rated speed		2700 rpm
7.4	Number of cylinders / Capacity of cylinders		3 - 1826 cm <sup>3</sup>
7.5	Fuel consumption according to VDI cycle		4.61 l/h
Miscellaneous			
8.1	Type of drive control		Electronic
8.2	Working hydraulic pressure for attachments		200 Bar
8.3	Oil flow rate for attachments		42 l/min
8.4	Measured/guaranteed mean noise level at the ear of the operator		< 79 dB(A)

## Dimensional drawing

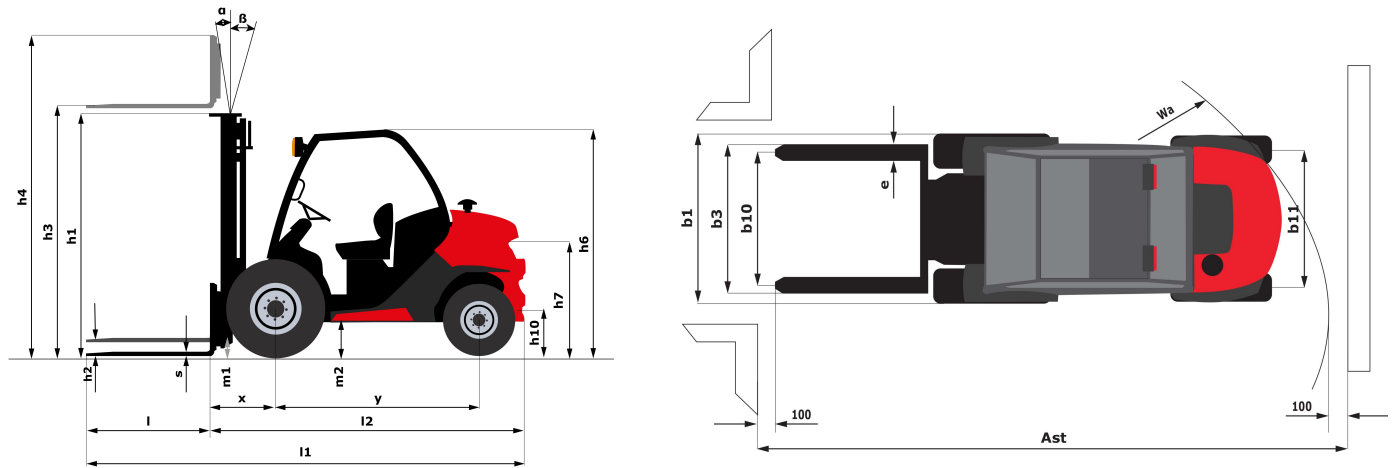

## Characteristics of masts and residual capacities

Full Visibility Duplex		FVD 33	FVD 37	FVD 45
h2 - Free lift	mm	112	112	112
h1 - Height mast lowered *	mm	2338	2598	3038
h3 - Lifting Height	mm	3300	3700	4500
h4 - Height mast extended *	mm	4090	4490	5290
α / β - Mast inclination (front / rear)	°	12 / 10	12 / 10	12 / 10
Residual capacity without attachment (Industrial load chart)	kg	2500	1450	800
Residual capacity with hooked-on side shift (Industrial load chart)	kg	2500	1450	800
Height at max capacity	mm	3000	3000	3000
Height at max capacity with hooked-on sideshift	mm	3000	3000	3000

Free Lift Triplex		FLT 34	FLT 37	FLT 40	FLT 43	FLT 47	FLT 55
h2 - Free lift	mm	1210	1310	1410	1510	1660	1920
h1 - Height mast lowered *	mm	1988	2088	2188	2338	2438	2788
h3 - Lifting Height	mm	3400	3700	4000	4300	4700	5500
h4 - Height mast extended *	mm	4236	4536	4836	5168	5536	6408
α / β - Mast inclination (front / rear)	°	12 / 10	12 / 10	12 / 10	12 / 10	12 / 10	6 / 6
Residual capacity without attachment (Industrial load chart)	kg	1900	1500	1350	800	700	5000
Residual capacity with hooked-on side shift (Industrial load chart)	kg	1800	1450	1350	700	700	5000
Height at max capacity	mm	3000	3000	3000	3000	3000	3000
Height at max capacity with hooked-on sideshift	mm	3000	3000	3000	3000	3000	3000

Full Visibility Triplex		FVT 33
h2 - Free lift	mm	124
h1 - Height mast lowered *	mm	1878
h3 - Lifting Height	mm	3300
h4 - Height mast extended *	mm	4079
α / β - Mast inclination (front / rear)	°	12 / 10



Siège Social

430 rue de l'Aubinière - 44150 Ancenis Cedex - France

Tel: +33(0)2 40 09 10 11 - Fax: +33 (0)2 40 09 10 97

[www.manitou.com](http://www.manitou.com)



This brochure describes versions and configuration options for Manitou products which may be fitted with different equipment. The equipment described in this brochure may be standard, optional or not available depending on version. Manitou reserves the right to change the specifications shown and described at any time and without prior warning. The manufacturer is not liable for the specifications given. For more information, contact your Manitou dealer. Non-contractual document. Product descriptions may differ from actual products. List of specifications is not comprehensive. The logos and visual identity of the company are the property of Manitou and may not be used without authorisation. All rights reserved. The photos and diagrams contained in this brochure are provided for information only.

MANITOU BF SA - Limited company with board of directors - Share capital: 39,668,399 euros - 857 802 508 RCS Nantes