

Technical sheet :

4200 V



| Capacities | | Metric |
|--|-----|-------------------------|
| Rated Operating Capacity | | 1905 kg |
| Unladen weight | | 5291 kg |
| Weight and dimensions | | |
| Overall Operating Height - Fully Raised | h27 | 4745 mm |
| Height to Hinge Pin - Fully Raised | h28 | 3647 mm |
| Overall Height to Top of ROPS | h17 | 2083 mm |
| Dump angle at full height | a5 | 31 ° |
| Dump height | h29 | 2916 mm |
| Overall length with bucket | l16 | 4026 mm |
| Dump reach at full height | | 1003 mm |
| Rollback at ground | | 31 ° |
| Seat to ground height | h30 | 1046 mm |
| Wheelbase | y | 1387 mm |
| Overall width less bucket | b1 | 2019 mm |
| Bucket Width | e1 | 2134 mm |
| Ground clearance | m4 | 185 mm |
| Overall length - Less Bucket | l2 | 3086 mm |
| Departure angle | a2 | 19 ° |
| Clearance Circle - Front without Bucket | b19 | 1290 mm |
| Clearance Circle - Rear | wa1 | 1791 mm |
| Performances | | |
| Travel Speed with Two-Speed Option - Maximum | | 18.70 km/h |
| Travel speed (unladen) | | 10.53 km/h |
| Wheels | | |
| Standard tyres | | 14x17.50 HD |
| Engine | | |
| Engine brand | | Deutz |
| Engine model | | TCD 3.6 |
| Gross Power (kW) | | 74 kW |
| Net Power (kW) | | 97.20 kW |
| Max. torque / Engine rotation | | 442 Nm / 2200 rpm |
| Battery | | 12 V |
| Alternator | | 130 kW |
| Starter (kW) | | 2.30 kW |
| Hydraulics | | |
| High-Flow Auxiliary Hydraulics - Option | | 154 l/min |
| Tank capacities | | |
| Fuel tank | | 39.40 l |
| Reservoir Capacity Hydraulics | | 63.40 l |
| Displacement | | 3.60 l |
| Noise and vibration | | |
| Environmental noise (LwA) | | 101 dB(A) |
| Noise at driving position (LpA) | | 85 dB(A) |
| Whole-Body Vibration (ISO 2631-1) | | 0.79 m/s ² |
| Vibration to whole hand/arm | | < 1.20 m/s ² |

Dimensional drawing

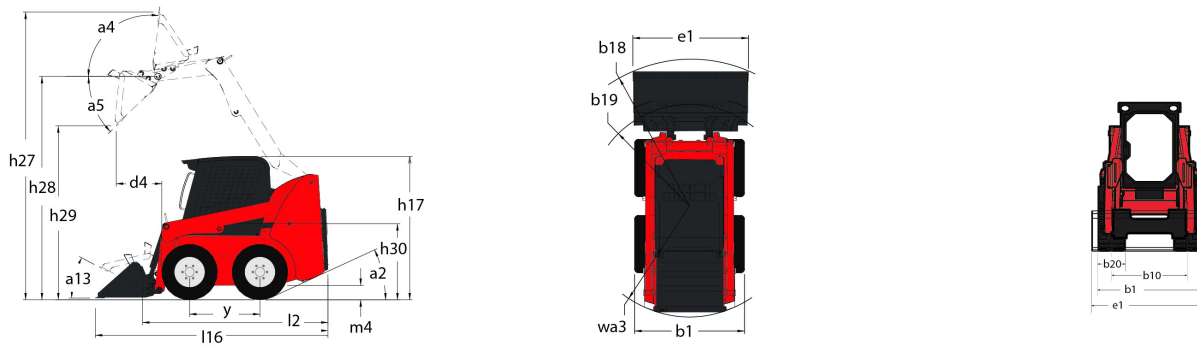

Equipment

| | |
|--|----------|
| — | |
| Integral Access Plate (removable) | Standard |
| Lifting function | |
| All-Tach® Attachment Mounting System | Standard |
| Auxiliary Hydraulics | Standard |
| High-Flow Auxiliary Hydraulics | Standard |
| Power-A-Tach® Attachment Mounting System | Standard |
| Lighting | |
| Work Lights - Front and Rear | Standard |
| Motorization/Power | |
| Engine Auto-Shutdown System | Standard |
| Engine Block Heater | Standard |
| Swing-Out Cooler | Standard |
| Turbo-Charged Engine | Standard |
| Two-Speed Drive | Standard |
| Operator station | |
| Adjustable Arm Rests / Control Towers 1 | Standard |
| Air conditioning with manual adjustment | Standard |
| Air suspension seat | Standard |
| Cab Enclosure | Optional |
| Foot and Hand Throttles 2 | Standard |
| Heating | Standard |
| High-Back Adjustable Seat | Standard |
| Horn | Standard |
| Joystick controls | Standard |
| ROPS/FOPS Level II Overhead Guard | Standard |
| Other options | |
| Hydrostatic Drive - Servo | Standard |
| Selectable Self-Leveling Hydraulic Lift Action 4 | Standard |
| Safety | |
| Anti-Vandalism Protection | Standard |
| Back-Up Alarm | Standard |
| Brake Control (Auto / Manual) | Standard |
| Hydraloc™ Safety System | Standard |
| Lift Arm Support Device | Standard |
| Operator Restraint Bar | Standard |
| Secondary functions | |
| Full Instrumentation | Standard |
| Hydraglide™ Ride Control 3 | Standard |



Siège Social

430 rue de l'Aubinière - 44150 Ancenis Cedex - France

Tel: +33(0)2 40 09 10 11 - Fax: +33 (0)2 40 09 10 97

www.manitou.com



This brochure describes versions and configuration options for Manitou products which may be fitted with different equipment. The equipment described in this brochure may be standard, optional or not available depending on version. Manitou reserves the right to change the specifications shown and described at any time and without prior warning. The manufacturer is not liable for the specifications given. For more information, contact your Manitou dealer. Non-contractual document. Product descriptions may differ from actual products. List of specifications is not comprehensive. The logos and visual identity of the company are the property of Manitou and may not be used without authorisation. All rights reserved. The photos and diagrams contained in this brochure are provided for information only.

MANITOU BF SA - Limited company with board of directors - Share capital: 39,668,399 euros - 857 802 508 RCS Nantes