

Farm King

OPERATOR AND PARTS MANUAL

Conventional Auger

8" & 10" x 61' Model



Table of Contents

Introduction5

Safety.....6

- Safety6
- General Safety.....7
- Start-up Safety7
- Operation Safety7
- Transport Safety8
- Service and Maintenance Safety8
- Storage Safety8
- Safety Signs9
- Safety Sign Installation9

Assembly..... 11

- Assembly Instructions 11

Operation 14

- Theory of Operations..... 16

Maintenance 18

- Storage 19

Bolt Torque 19

- Checking Bolt Torque 19

Parts Drawings.....20

- Tube Assembly Drawing.....20
- Tube Assembly Parts List.....21
- Undercarriage, Axle and Lift Arm Assembly Drawing24
- Undercarriage, Axle and Lift Arm Assembly Parts List25
- 8" Bridging Assembly Drawing.....27
- 10" Bridging Assembly Drawing28
- Bridging Assembly Parts List29
- Cable Assembly Drawing30
- Cable Assembly Parts List31
- Direct Drive Assembly Drawing.....32
- Direct Drive Assembly Parts List.....33
- Clamp-on Motor Mount Assembly Drawing.....34
- Clamp-on Motor Mount Assembly Parts List.....35
- Clamp-on Motor Mount Kit Instructions36

• Winch Drawing.....	38
• Winch Parts List.....	39
• PTO Assembly Drawing.....	42
• PTO Assembly Parts List.....	43
• Gearbox Drawing.....	44
• Gearbox Parts List.....	45
• Reverse Gearbox Drawing	46
• Reverse Gearbox Parts List	47
• Belt Drive Gearbox Drawing	48
• Belt Drive Gearbox Parts List	49
• Reverse Shift Belt Drive Gearbox Drawing.....	50
• Reverse Shift Belt Drive Gearbox Drawing.....	51
Shipping Kit and Bundle Numbers	52
Warranty	54

Manufacturer's statement: for technical reasons Buhler Industries Inc. reserves the right to modify machinery design and specifications provided herein without any preliminary notice. Information provided herein is of descriptive nature. Performance quality may depend on soil fertility, applied agricultural techniques, weather conditions and other factors.

Introduction

The Farm King conventional augers deliver numerous well-proven design features for more convenience, efficiency and safety. A longer bottom end below the gearbox allows the auger further into the bin.

These augers are well balanced for easy handling. A belt tightener and improved hinged belt-guards provide you with added convenience and an extra measure of safety. Beefy, wide-stance undercarriages and lift-systems with automotive-type hubs and bearings are all Farm King standards. Strength and stability come with square tube construction. Farm King gives you all the drive options:

- Direct PTO
- Belt Drive PTO
- Gas Engine Drive
- Electric Motor Drive (belt and direct)

All belt drive engine models have self-levelling motor mounts. Reliable safety clutch winches are used. The double flighting intake rotates in a brass bushing on all conventional auger intake guards. A new, narrow safety guard and removable clevis hitch allows for easier penetration into smaller openings. A storage bracket holds the clevis hitch when not needed. Sealed lubrication in the top drive assembly makes it resistant to heat, dust, debris and moisture. It also reduces maintenance requirements and adds to the longevity of the chain and sprockets.

Keep this manual handy for frequent reference. All new operators or owners must review the manual before using the equipment and at least annually thereafter. Contact your Farm King Dealer if you need assistance, information, or additional copies of the manual. Visit our website at www.buhlerindustries.com for a complete list of dealers in your area.

The directions left, right, front and rear, as mentioned throughout this manual, are as seen facing in the direction of travel of the implement.

Safety

Safety Instructions

Remember, YOU are the key to safety. Good safety practices not only protect you, but also the people around you. Make these practices a working part of your safety program. Be certain that everyone operating this equipment is familiar with the recommended operating and maintenance procedures and follows all the safety precautions. Most accidents can be prevented. Do not risk injury or death by ignoring good safety practices.

The alert symbol is used throughout this manual. It indicates attention is required and identifies hazards. Follow the recommended precautions.



The safety alert symbol means...
ATTENTION! BECOME ALERT! YOUR SAFETY IS INVOLVED!



CAUTION

The caution symbol indicates a potentially hazardous situation that, if not avoided, may result in minor or moderate injury. It may also be used to alert against unsafe practices.



WARNING

The Warning Symbol indicates a potentially hazardous situation that, if not avoided, could result in death or serious injury, and includes hazards that are exposed when guards are removed. It may also be used to alert against unsafe practices.



DANGER

The Danger Symbol indicates an imminently hazardous situation that, if not avoided will result in death or serious injury. This signal word is to be limited to the most extreme situations, typically for machine components that, for functional purposes, cannot be guarded.

General Safety Instructions

- Have a first-aid kit available for use and know how to use it.
- Have a fire extinguisher available, stored in a highly visible location, and know how to use it.
- Wear appropriate protective gear. This list may include but is not limited to:
 - hard hat
 - protective shoes with slip resistant soles
 - protective glasses or goggles
 - heavy gloves
 - wet weather gear
 - hearing protection
 - respirator or filter mask
- Read and understand the Operator's Manual and all safety signs before operating, servicing, adjusting, repairing, or unplugging the equipment.
- Do not attempt any unauthorized modifications to your Farm King product as this could affect function or safety, and could affect the life of the equipment.
- Inspect and clean the working area before operating.
- Keep hands, feet, clothing, and hair away from moving parts.
- Ensure bystanders are clear of the area before operating.

Start-Up Safety

- Do not let inexperienced operators or children run this equipment.
- Place all tractor and machine controls in neutral before starting.
- Operate only with ROPS and seatbelt equipped tractors.
- Do not operate inside a building unless there is adequate ventilation.
- Ensure all shields are in place and in good condition before operating.
- Stay clear of PTO shaft and machine when engaging PTO.
- The auger must be on a level surface and wheels free to move when raising or lowering. Everyone should be kept clear during these operations.
- Make certain electric motors are grounded.

Operation Safety

- Do not permit riders.
- Do not wear loose fitting clothing during operation.
- Empty the auger before moving to prevent upending.
- Do not allow anyone other than the operator close to the Auger when in operation.
- Never stand under the auger while raising or lowering.
- When filling tall bins, tanks, or granaries, it is advisable to anchor the auger to the bin or building to prevent it from being tipped over by the wind or a sudden movement.
- Never operate a Conventional Auger with the intake end off the ground.
- Never operate over 540 PTO rpm speed.
- Never raise the intake end of the auger above waist high, as the balance shifts forward, and the auger will tip over.
- Stay away from overhead obstructions and power lines during operation and transporting.
- Electrocutation can occur without direct contact.

Transport Safety

- Review Transport Safety instructions in tractor manual before moving.
- Check with local authorities regarding transport on public roads. Obey all applicable laws and regulations.
- Do not tow equipment that does not have brakes at speeds over 20 mph (32km/h).
- Do not tow equipment that does not have brakes that, when fully loaded, has a mass (weight) over 3300 lb (1.5 t) and more than 1.5 times the mass (weight) of the towing unit.
- Make sure the SMV (Slow Moving Vehicle) emblem and all the lights and reflectors that are required by the local highway and transport authorities are in place, are clean, and can be seen clearly by all overtaking and oncoming traffic.
- Never have the equipment in operation during transport.
- Always transport the Conventional Auger in the down position, carrying the weight of the auger on the winch cable and not on the track stops.
- Take extreme caution in maneuvering on or around tight corners so as not to catch the end of the auger on trees, buildings, power lines, etc.
- The equipment should never be towed without the safety chain securely attached to the auger and the towing vehicle.
- When moving the auger on the road, always use a red flag, or if absolutely necessary to move at night, accessory lights for adequate warning to operators of other vehicles.
- Always travel at a safe speed.
- Inflate transport tires to recommended pressure.

Service and Maintenance

- Stop engine, set brake, remove ignition key, and wait for all moving parts to stop before servicing, adjusting, repairing, or unplugging.
- Support the equipment with blocks or safety stands before working beneath it.
- Follow good shop practices including:
 - keep service area clean and dry
 - be sure electrical outlets and tools are properly grounded
 - use adequate light for the job.
- Use only tools, jacks, and hoists of sufficient capacity for the job.
- Replace and secure all shields removed during servicing before operating.
- Use heavy leather gloves to handle sharp objects.
- Failure to follow proper procedures when mounting a tire on a wheel or rim can produce an explosion, which may result in serious injury or death.

Storage Safety

- Store the unit in an area away from human activity.
- Do not permit children to play on or around the stored machine.
- Support the frame on stands and blocks to provide a secure base.
- When storing an Auger, park it on level ground so that the bottom end will never be over its center of gravity.
- Block the wheels of the Auger so that it will not move and tear the jack from it's mount.
- When storing the auger, the intake end should be tied or weighted to prevent tipping.

Safety Signs

- The following illustration shows the approximate location and detail of safety signs.
- Keep all safety signs clean and legible and replace any that are damaged or missing.
- When original parts are replaced, any safety signs affixed to those parts should be replaced as well. Replacement safety signs are available from your local dealer.

Installation

- To install safety signs, ensure the installation area is clean and dry. Decide on the exact position before you remove the backing paper. Remove the smallest portion of the split backing paper and align over the specified area. Carefully press in place.
- Slowly peel back the remaining paper and smooth the remaining portion in place. Small air pockets can be pierced with a pin and smoothed out.



CA-18

- Replace safety signs immediately should they become damaged, torn or illegible. Obtain replacements from your authorized dealer using the part numbers shown.

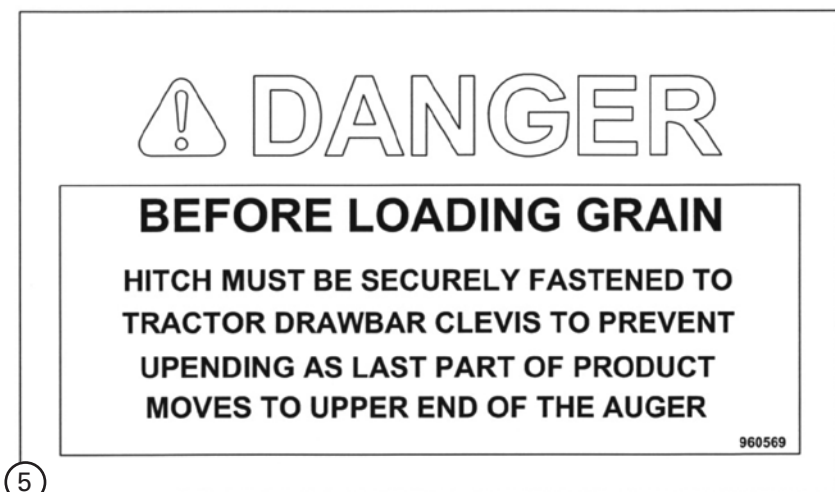
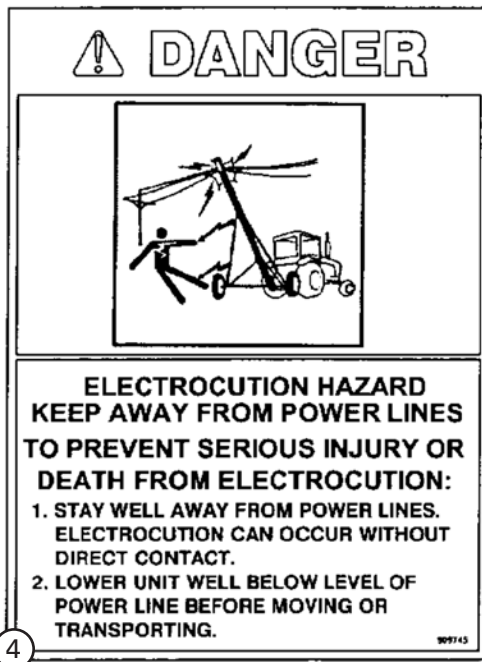
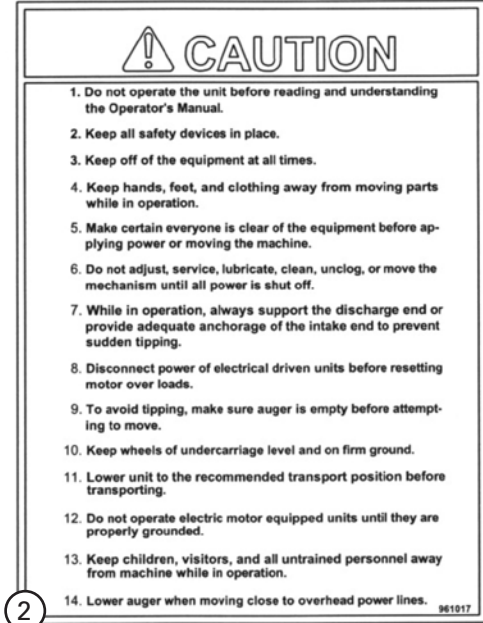

Assembly Instructions

1. Assemble the top section (#3) to the center section (#2) making sure the flighting is aligned and locked with a hex bolt and lock nut (8" – 3/8" x 2" grade 8, 10" – 1/2" x 2-3/4" grade 8). The drivelines for the two sections are connected using a 1-5/16" SQ. x 5-1/2" coupler (#70). Similarly assemble the bottom section (#1) to the center section. Use hex bolts, lock washers and hex nuts to fasten the auger rings together (8" – 3/8" x 1", 10" – 1/2" x 1-1/4"). Align all three sections before tightening the bolts. Be sure to tighten bolts evenly – first one side and then the other. Bolt the intake assembly (#13) to the bottom of the auger using 3/8" x 2" hex bolts, lock washers and hex nuts.
2. Page 22: The gearbox is shipped without oil. Before you mount the gearbox on the auger, remove the lid and fill the gearbox about 1/3 full with SAE80-90 oil. (Oil should be just touching the bottom of the gears, do not overfill). Use gasket glue when replacing the cover to reduce the chance of leaks. The gearbox may be used on either the left or the right side. Check to see that the breather plug on the gearbox lid will be on the top and the drain plug will be at the bottom when the gearbox is bolted to the auger. Connect the gearbox to the splined coupler on the driveline and bolt on the gearbox using 1/2" x 1" hex bolts and lock washers.

Bolt the gearbox plate (#54) to the top of the gearbox with the ring on the drive side. The extension shield holder (#55) bolts on top of the gearbox plate with the welded bolt turned towards the top of the auger. Use the same hardware as for the gearbox.

3. Page 22: Mount the drive line shields (#8) starting at the top of the auger before you lift the auger. The final extension shield (#7) will be mounted after the auger is assembled. Bolt the extension shield to the shield holder (#55) using a 5/16" flat washer, lock washer and hex nut.
4. Pages 29-30: Bridging should be assembled on the main auger tubes before raising the auger.

8" x 61' auger - The two bridging brackets (#4) are bolted to the mounts welded to the center section using 1/2" x 1-1/2" hex bolts, lock washers and hex nuts. Attach the cross braces (#5) to the top of the bridging yokes using 3/8" x 1-1/4" hex bolts, lock washers and hex nuts. Attach the bridging cables (#13) to the yokes using 3/8" cable clamps and 3/8" I.D. (10 ga.) flat washers. Bolt cables to the bottom section and tension at the top using a nut and flat washer. The main tubes must be straight or bowed up slightly before lifting auger. Any downward bow will result in very loud flighting noise.



WARNING

Do not tighten the cable clamps on the bridging yokes until after the cables are tight before lifting the auger.

10" x 61' auger - The main bridging yoke (#20) is bolted to the lower bridging mount on the center section using 1/2" x 1-1/2" hex bolts, lock washers and hex nuts. Attach the tie bar (#21) to the top of the main bridging yoke using 3/8" x 1-1/4" hex bolts, lock washers and hex nuts. The upper bridging yoke (#15) bolts to the welded mount near the top of the center section using 1/2" x 1-1/2" bolts. Mount both sets of cables (#18) and (#19). The longer cable goes from just above the gearbox, across both bridging yokes, to the top section. The shorter cable goes from just behind the undercarriage pivot pin, across the main bridging yoke, down to the welded cable brackets just below the upper bridging yoke. Bolt the cable yokes (#16) to the bottom of each cable using 1/2" x 2" hex bolts, lock washers and hex nuts. Bolt the yokes to the cable brackets welded to the main tubing with the same hardware. Use the bottom hole in the

yoke if possible. The other holes can be used if the cable stretches after a few years. Tighten the cables using a flat washer and hex nut. The main tubes must be straight or bowed up slightly before lifting auger. Any downward bow will result in very loud fighting noise.

**ALERT**

Use 3/8" I.D. (10 ga.) flat washers on all cable clamps. Tighten the cable clamps on the bridging yokes after the cables are tight and before lifting the auger.

5. Page 22: Raise the top end of the auger tube assembly. Bolt the pulley holder (#25) to the bottom of the track using 3/8" x 1" hex bolts, lock washers and hex nuts. Turn as shown in drawing. Slide the track roller assembly onto the track with the cast rollers and cable pulleys turned to the bottom of the auger. Bolt the track stop (#21) to the track using 3/8" x 1-1/4" hex bolts, lock washers and hex nuts. Track stop bolts about 6" above the pulley holder at the bottom of the track.
6. Page 26: Mount the two undercarriage arms (#1) and (#2) to the pivot pin under the welded gearbox mount using 1-1/2" washers (#37) and 5/16" x 2-1/4" cotter pins (#38). Bolt the undercarriage arms to the axle (#5) using hex bolts, lock washers and hex nuts (8" – 5/8" x 3-1/2"; 10" – 5/8" x 4-1/2") Bolt on the left (#3) and right (#4) cross brace tubes between the undercarriage and axle. The right hand cross brace (#4) has the winch bracket. Bolt to the undercarriage using 3/4" bolts, lock washers and hex nuts (8" – 3-1/2", 10" – 4-1/2"). The other end of the cross brace bolts to the inside of the welded brackets on the axle tube using 5/8" x 1 3/4" hex bolts, lock washers and hex nuts.

Bolt the lift arm extension (#8) to the track roller using a 3/4" x 6" bolt and lock nut. Bolt the lift arm extension to the top of the two lift arms (#6) and (#7) using 5/8" x 5-1/2" bolts, lock washers and hex nuts. The bottom of the lift arms bolts between the welded brackets on the cross brace tubes using 3/4" x 2-1/2" bolts and lock nuts. Join the two lift arms with a cross brace (#58) and two plates (#57). Use 3/8" x 3" bolts, lock washers and hex nuts for the 8" and 4" bolts for the 10".

7. Page 26: Bolt the idler mounting plate (#49) to the undercarriage arms just above the ends of the cross brace tubes using 3/8" hex bolts, lock washer and hex nuts (8" – 3"; 10" – 4"). The edge with the cable pulley faces down. Fit the slots in the winch bracket onto the right hand cross tube and slide against the welded stop. The slots in the winch bracket at 90° to the cross tube are turned up. Bolt in place using two connector plates and 3/8" x 1-1/4" hex bolts, lock washers and hex nuts. Bolt the winch (#9) to the winch bracket (#12) on the right hand cross tube (#4) using 3/8" x 1" hex bolts, lock washers and hex nuts. Flat washers are supplied for bolts, which go through slotted holes.
8. Page 26: Bolt the swivel pulley holder (#40) to the loops at the top and inside of the undercarriage using 5/16" x 2" hex bolts, lock washers and hex nuts. The pulley holder is offset on the shaft. Turn the pulley so the offset is towards the same side as the drive.
9. Page 32: Thread the cable (#1) as shown in the drawing. From the winch the cable goes around the cable pulley on the idler plate. From there you go around the swivel pulley at the top of the undercarriage. Loop around the cable pulleys as shown in the drawing. The upper two cable pulleys are the ones in the track roller. The lower two cable pulleys are the ones at the bottom of the track. The end of the cable is clamped to the cable anchor welded to the track roller. Clamp the cable to the winch spool using the clamps supplied with the winch.

10. Page 26: A clevis holder (#46) bolts to the top end of one undercarriage arm using a 3/8" hex bolt, lock washer and hex nut (8" – 3"; 10" – 4"). This holder is used as a place to leave the intake swivel clevis when it is removed prior to inserting the auger in a bin.
11. Page 26: Mount the wheels (#36) and tires on the axle using 1/2" wheel bolts and torque bolts to 80 ft/lbs (108 N-m).
12. Page 34: All 61' augers are available as PTO direct drive only.
 - Bolt the PTO hanger (#9) to the welded bracket on the tube using 3/8" x 1" cap screws, lock washers and hex nuts. A pin (#7) holds the PTO in place during transport.
 - Mount the PTO guard holder (#14) to the welded ring on the gearbox plate using a 4" I.D. clamp (#15) with 5/16" x 1-1/4" hex bolts, lock washers and hex nuts.
 - Slide the flexible PTO guard (#2) and the guard clamp (#3) onto the PTO shaft. Attach the PTO shaft using a key (8" – 1/4"; 10" – 3/8"), set screws and clamp bolt. Securely tighten the set screws and clamp bolt. After mounting the PTO, clamp on the flexible PTO guard (#2) using a 5/16" x 1-1/4" hex bolt, lock washer and hex nut.
13. Re-check and tighten all bolts. Of particular importance are:
 - Cable clamps and winch.
 - Bolts on track roller assembly.
 - Bolts on lift arm joining axle and extension tube.
 - Bolts joining undercarriage, cross tubes and axle.
 - Gearbox mounting bolts.
 - Track stop bolts.
 - All bolts on shields.
 - Wheel bolts.
 - Set screws and clamp bolts holding on the PTO shaft.
 - Auger tube flange bolts.
14. NOTES:
 - Gearbox is shipped without oil. Add oil as described in section 2.
 - Do not exceed 600 rpm flying speed when operating auger.
 - An external chain tightener is supplied with all augers.
 - High position: it is dangerous to move auger in raised position in vicinity of electrical lines.
 - Keep all shields and guards in place.
 - Turn off power when servicing or unplugging auger.
 - Check that intake guard bolts are tight and that the swivel clevis pin has the hitch pin in place before transporting the auger.

Operation Instructions

- All augers may be elevated up to 45°: however, for best operating efficiency, 35° should not be exceeded. At angles over 35° the capacity and life of the auger decreases.
- Never operate an empty auger for over one minute, as the flighting and housing will experience excessive wear.
- To position the auger, always tow or move the auger in the down position to a point as close as possible to the bin or barn.



ALERT

Always keep the wheels level. Raise the auger to the desired height and back the auger into position. As an auger is emptied the head becomes heavy, the tail becomes light, and the auger could tip.



ALERT

Never place blocks under the wheels to increase the elevation of auger.

- Be sure the wheels are free to move and no one is standing close to the auger when raising or lowering. Never attempt to raise or lower the auger while it is in operation.
- The auger is equipped with a safety brake winch. The auger may be raised or lowered by simply turning the winch handle in the proper direction until the desired discharge height is obtained.
- Never have less than three wraps of cable on the drum of the winch.



ALERT

Arrow on winch shows proper direction of rotation. Improper rotation may cause winch brake failure.



ALERT

All wiring should be done by a competent electrical contractor to ensure the electric motor is receiving the correct voltage and the cable will carry the correct load.

- The life of a motor is greatly reduced if it is run at too high or too low voltage. Also, a motor cannot develop full power if the cable is too small. The electrical supply to each motor should include an enclosed safety switch or circuit breaker of the correct size to protect the motor from being overloaded. The switch should be under a padlock to prevent the motor from being turned on by accident while working on or moving the auger. This will also prevent unauthorized people or children from operating the motor. A magnetic starter should be used to shut off the motor in case of low voltage, loss of power, or overloading the motor.

- The electric motor must then be started manually.
- Power take-off drives are designed for tractors with 540 PTO rpm and should not be run by tractors with 1000 PTO rpm.

**CAUTION**

Always check to see that both ends of the PTO shaft are securely attached before using any PTO drive auger. This should always be done with the tractor shut off.

- To ensure a long life from a PTO tumbler shaft, operate the shaft at the least angle possible and always keep the tractor axle parallel to the side of the auger housing.

**ALERT**

Always maintain at least a 6" overlap on the tumbler shields. Be sure they turn freely and make certain everyone stands clear of the tractor, tumbler shaft, and auger before engaging PTO. Be sure ends are securely connected to the auger and tractor.

- Before engaging PTO, start tractor and idle engine. Engage PTO slowly and bring up to recommended speed of 500 PTO rpm.
- Before stopping auger (except in an emergency) let all grain empty out of the auger, idle engine then disengage PTO. Shut off tractor.

**ALERT**

When operating an auger for the first time when new or at the beginning of a season, run only partially full until flighting becomes polished. It is always a good idea to check the flighting for freedom of movement by turning pulley or tumbler shaft by hand before connecting to a power source. Other items to check are the head (spout) and intake cage for bird nests or other obstructions before starting the auger.

**ALERT**

Always lower auger before transporting and allow the weight of the auger to rest on the winch cable and not on the transport stops.

**ALERT**

When towing the auger, never exceed 32 km/h (20 mph).

- Use signal lights and a safety rated tow chain when towing an auger on a road. Check your local regulations for further safety devices in this regard.

Theory of Operations

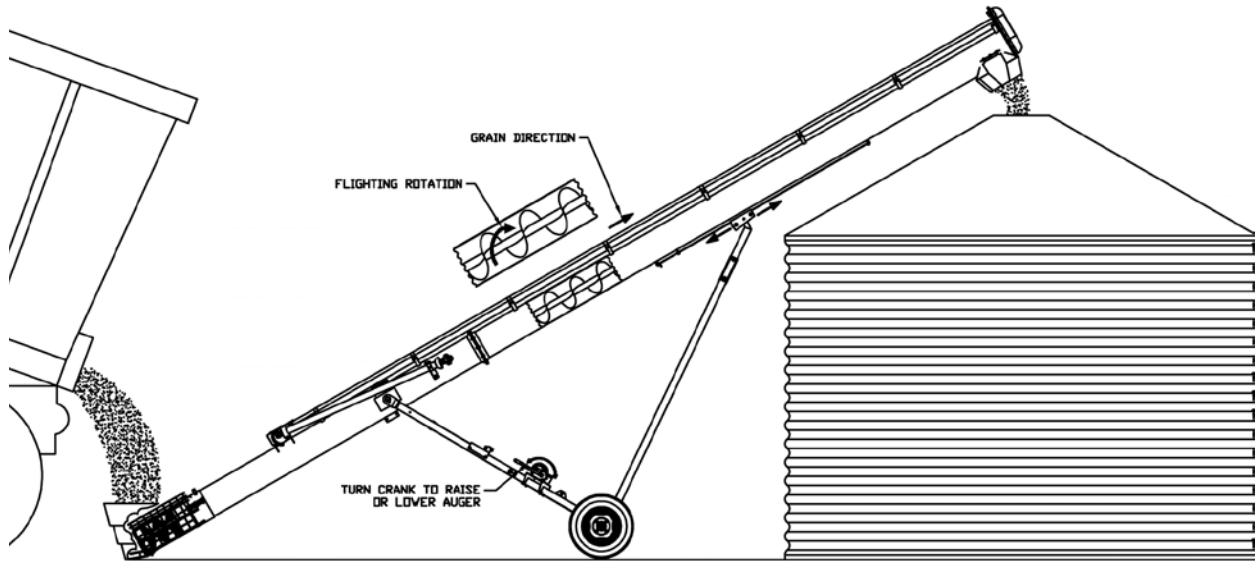

CA-41

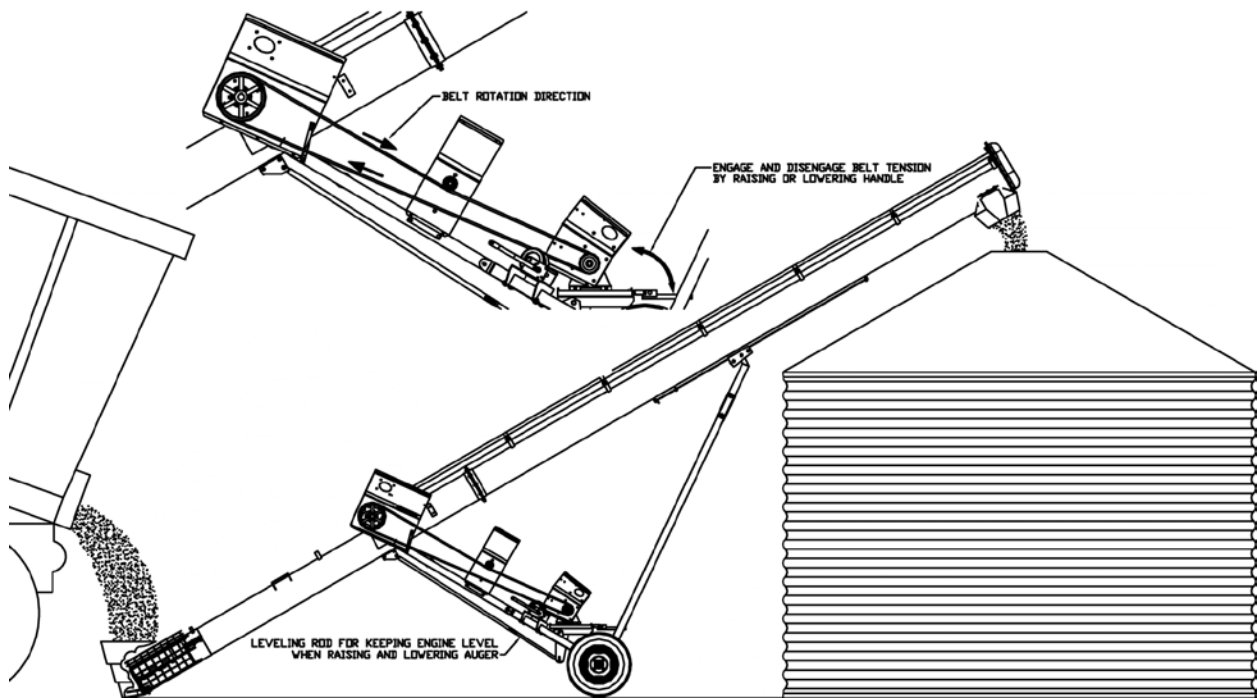

CA-42

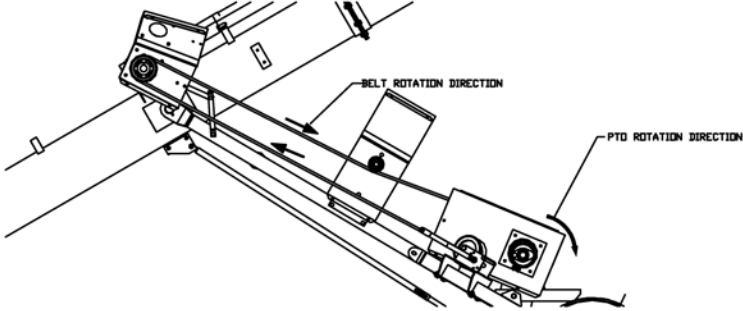
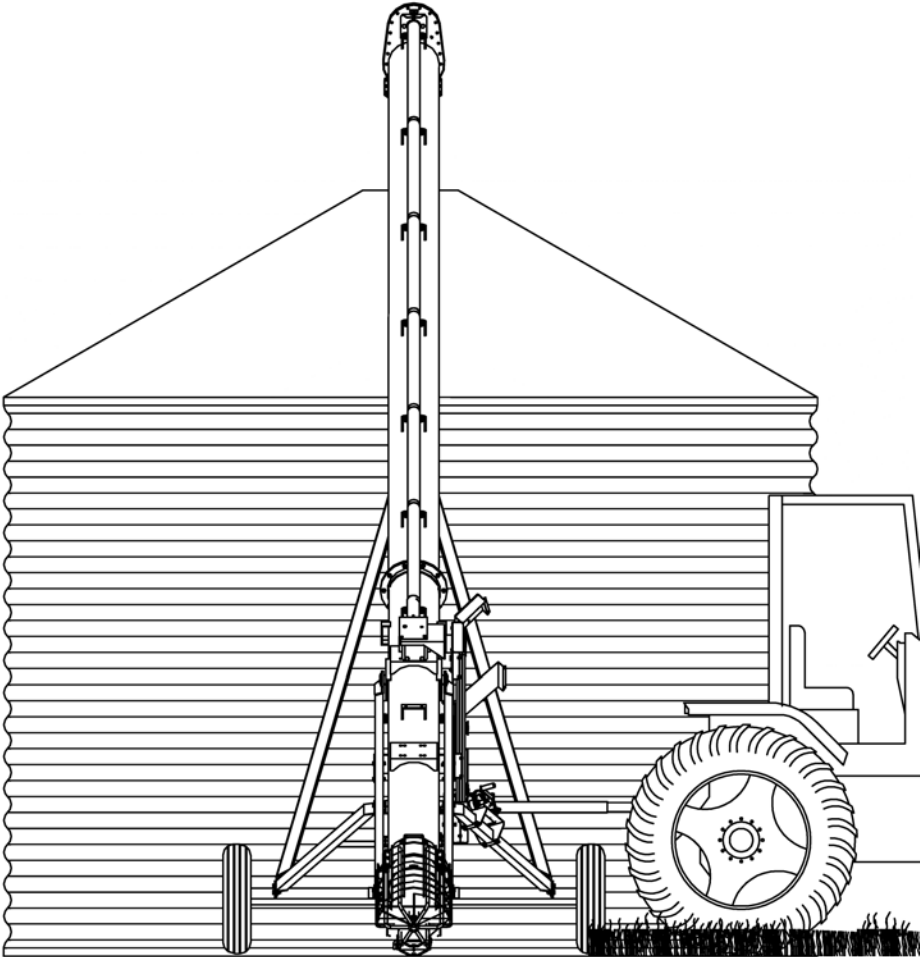

CA-43

Maintenance Instructions

- Check condition of winch cable occasionally and replace if it shows wear. The greatest wear will occur on the first few wraps around the drum of the winch.
- The main thing to check on the cable is for broken strands or rust, which penetrates the cable core. This is particularly important if the auger is more than a few years old.
- Oil the moving parts of the winch two times per year.
- Lubricate the PTO tumbler shaft universal joints every five hours. Grease the PTO shear yoke before using PTO for the first time.
- Oil the moving parts of the winch two times per year.
- Check the oil level of the gearbox one time per year and maintain the level at 1/2 full. Use SAE90.



ALERT

When replacing bearings or tightening a loose bearing collar, always tighten collar in the direction of shaft rotation using a center punch or a similar tool.

- The plastic chain guard at the top of the auger must be removed to inspect or replace the chain and sprockets. When replacing the plastic guard, clean off the residue from the old silicone and apply a fresh bead using a caulking gun. There must be about 2 lbs (0.9 kg) of grease in the guard. The bolts should be tightened in a criss-cross sequence to ensure proper seating of the guard. The bolts are a 1/4" grade 5 which should be torqued to about 9 ft-lbs (12 N-m) using a torque wrench.
- After every 40 hours of use, add approximately 10 squirts of grease to chain cover at the top of the auger.
- If the auger is towed extensively, the wheel bearings should be repacked at least semi-annually. Keep tire pressure at 37 psi maximum. (255 kPa)
- Regularly check the tightness of all cable clamps to avoid slipping.
- Inspect wire rope regularly for evidence of wear or corrosion. Such inspections should take place at progressively shorter intervals over the useful life of the rope, as wear tends to accelerate with use and/or age. Where wear is rapid, the outside of a wire rope will show flattened surfaces in a short time. A piece of cloth or rag, rubbed along the wire rope will help to reveal broken wires. The effects of corrosion are not easy to detect because the exterior wires may appear to be only slightly rusty, and the damaging effects of corrosion may be confined to the hidden inner wires where it cannot be seen. To prevent damage by corrosion, the rope should be kept well lubricated. Periodic cleaning of wire rope by using a stiff brush and kerosene or with compressed air or live steam and relubricating will help to lengthen rope life and reduce abrasion and wear on sheaves and drums.





Storage

- The auger should be stored in a dry place if possible. If stored outside, lower auger to its lowest position and tie the tail end down so that no one can accidentally overturn it.
- Clean auger thoroughly as dirt draws moisture and causes metal to rust. If the auger has been used to move fertilizer, clean thoroughly and apply oil or grease on entire flighting and inside the housing to stop and prevent further corrosion.
- Remove belts and store in a cool dry place if auger is to be left outdoors.
- At this time check all moving parts for wear and order replacement parts from your nearest dealer.
- When taking the auger out of storage, clean it thoroughly and check for obstructions at the inlet and outlet ends. Check the oil in the gearbox.
- Check all bolts and set screws.

Bolt Torque

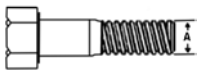
Checking Bolt Torque

The tables shown below give correct torque values for various bolts and hex bolts. Tighten all bolts to the torques specified in chart unless otherwise noted. Check tightness of bolts periodically, using bolt torque chart as a guide. Replace hardware with the same strength bolt.

Bolt Torque*						
						
Bolt Diameter (inches)	Grade 2 Bolts SAE 2		Grade 5 Bolts SAE 5		Grade 8 Bolts SAE 8	
"A"	(lb-ft)	(N.m)	(lb-ft)	(N.m)	(lb-ft)	(N.m)
0.25 (1/4)	6	8	9	12	12	17
0.313 (5/16)	10	13	19	25	27	36
0.375 (3/8)	20	27	33	45	45	63
0.438 (7/16)	30	42	53	72	75	100
0.5 (1/2)	45	61	80	110	115	155
0.563 (9/16)	70	95	115	155	165	220
0.625 (5/8)	95	128	160	215	220	305
.75 (3/4)	165	225	290	390	400	540
0.875 (7/8)	170	230	420	570	650	880
1	225	345	630	850	970	1320

Torque figures indicated above are valid for non-greased or non-oiled threads and heads unless otherwise specified. Therefore, do not grease or oil bolts or hex bolts unless otherwise specified in this manual. When using locking elements, increase torque values by 5%.

*Torque value for bolts and hex bolts are identified by their head markings.

Tube Assembly Drawing

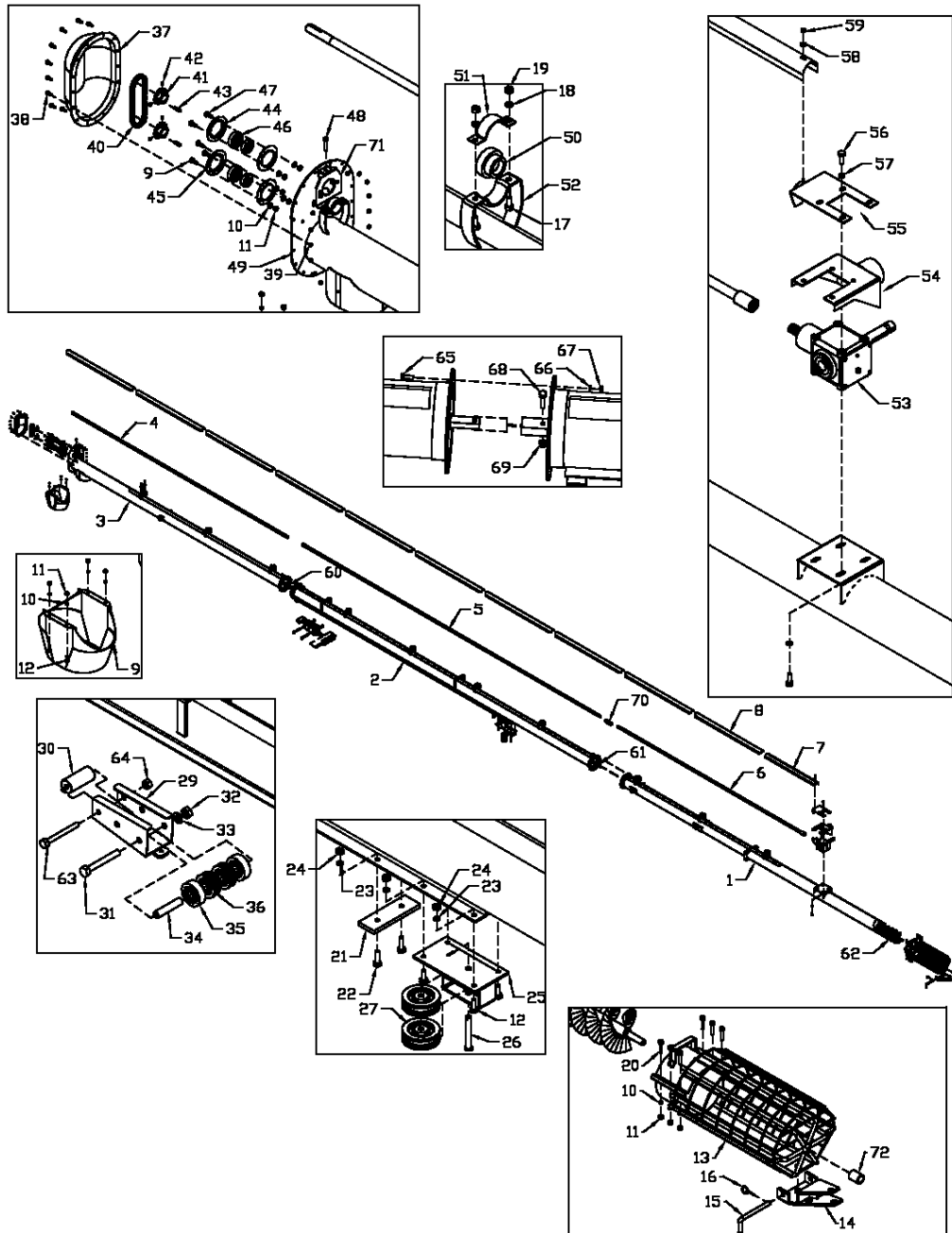

When Ordering Parts

Always give your dealer the Model, Color and Serial Number of your machine to assist him in ordering and obtaining the correct parts. Use the exploded view and tabular listing of the area of interest to exactly identify the required part.

Item	Part Number	Description
1	908967	Bottom Section Tube 8" x 20'
	962018	Bottom Section Tube 10" x 20'
2	908968	Center Section Tube 8" x 23' 6"
	962019	Center Section Tube 10" x 23' 6"
3	908969	Top Section Tube 8" x 16' 6"
	962020	Top Section Tube 10" x 16' 6"
4	962021	Top Drive Line Tube 17' 1/8"
5	962022	Center Drive Line Tube 23'- 5-7/8" Lg
6	961260	Bottom Drive Line Tube 14'- 8-7/8" Lg
	910054	Drive Line 62-5/8" Lg (10" x 61' Engine Belt Drive)
7	962023	Extension Drive Line Shield 47" Lg (8" x 61')
	962024	Extension Drive Line Shield 49" Lg (10" x 61')
8	961987	Drive Line Shield 62-1/2" Lg (8" x 61')
	961264	Drive Line Shield 48-1/4" Lg (10" x 61')
9	961339	10" Bolt On Spout
10	81593	3/8" Lock Washer (pl)
11	81592	3/8" Hex Nut (pl)
12	86170	3/8" x 1" Hex Bolt (pl)
13	903556	8" x 61' Intake Guard Weldment
	903558	10" x 61' Intake Guard Weldment
14	903248	Clevis Weld't (8")
	903294	Clevis Weld't (10")
15	903246	Clevis Pin 5/8" x 9" (8")
	903293	Clevis Pin 5/8" x 10-1/2" (10")
16	966729	3/16" Linch Pin
17	81549	5/16" x 3/4" Hex Bolt (pl)
18	81569	5/16" Lock Washer (pl)
19	81568	5/16" Hex Nut (pl)
20	811795	3/8" x 2" Hex Bolt (pl)
21	962025	Track Stop
22	86171	3/8" x 1-1/4" Hex Bolt (pl)
23	81593	3/8" Lock Washer (pl)
24	81592	3/8" Hex Nut (pl)
25	962026	Pulley Holder Weldment
26	961011	Clevis Pin 1/2" x 3-1/2" Lg
27	961846	Cable Pulley 1/2" Bore

Item	Part Number	Description
29	962027	Track Roller Frame
30	902365	Rear Track Roller
31	84215	3/4" x 6" Hex Bolt (pl)
32	81700	3/4" Hex Nut (pl)
33	81701	3/4" Lock Washer (pl)
34	962028	Track Spacer .995" O.D. x 4-9/16" Lg
35	961844	Track Roller 3-1/2" Dia. x 1" Bore
36	961845	Track Cable Pulley 3-1/2" Dia. x 1" Bore
37	961098	Plastic End Cover
38	967473	1/4" x 3/4" Flange Bolt (pl)
39	967474	1/4" Flange Nut (pl)
40	961997	#80 Chain 36 Link (8")
	961181	#80 Chain 38 Link (10")
41	961998	#80 20T Sprocket 1-3/8" Bore
42	985639	3/8" x 1/2" Socket Set Screw
43	967041	5/16" Sq. x 1-1/2" Key
44	961091	2-Hole Flange (1-3/8")
45	961675	3-Hole Flange (1-3/8")
46	965917	1-3/8" Bearing
47	9812387	3/8" x 1" Carriage Bolt
48	967291	3/8" x 2" Full Thread Bolt (pl)
49	961308	8" x 61' Tube End Plate
	904787	10" x 61' Tube End Plate
50	965917	1-3/8" Bearing
51	961990	1-3/8" Bearing Cap
52	961989	Bearing Stand
53	BU50510	Gearbox
	907207	Gearbox (1061 BD)
	961086	Reverse Shift Gearbox (Optional)
	907413	Reverse Shift Gearbox (Optional 1061 BD)
54	961348	Gearbox Plate
55	961346	Extension Drive Line Shield Holder
56	81619	1/2" x 1" Hex Bolt (pl)
57	81637	1/2" Lock Washer (pl)
58	81570	5/16" B.S. Flat Washer (pl)
59	81568	5/16" Hex Nut (pl)
60	962029	Top Section Flighting 8" x 16'-11-1/2" Lg
	962030	Top Section Flighting 10" x 16'-11-1/2" Lg
61	962031	Center Section Flighting 8" x 23'- 8-3/8" Lg
	962032	Center Section Flighting 10" x 23'- 8-3/8" Lg
62	905243	Bottom Section Flighting 8" x 21'- 9-1/2" Lg

Item	Part Number	Description
	961255	Bottom Section Flighting 10" x 21'- 9-1/2" Lg
63	812087	5/8" x 6" Hex Bolt (pl)
64	812482	5/8" Hex Nut (pl)
65	86170	3/8" x 1" Hex Bolt (pl) (8")
	81620	1/2"x 1-1/4" Hex Bolt (pl) (10")
66	81593	3/8" Lock Washer (pl) (8")
	81637	1/2" lock Washer (pl) (10")
67	81592	3/8" Hex Nut (pl) (8")
	81636	1/2" Hex Nut (pl) (10")
68	9812483	3/8" x 2" Hex Bolt Gr. 8 (pl) (8")
	9812368	1/2" x 2-3/4" Hex Bolt Gr.8 (pl) (10")
69	812363	3/8" Lock Nut (pl) (8")
	812364	1/2" Lock Nut (pl) (10")
70	961648	1-5/16" Sq. Hollow Coupler 5-1/2" Long
71	903478	Chain Tightener Bracket
72	960461	Brass Bushing 1-3/8" x 1-3/4" Lg (8")
	967915	Brass Bushing 1-5/8" x 1-3/4" Lg (10")

Undercarriage, Axle and Lift Arm Assembly Drawing

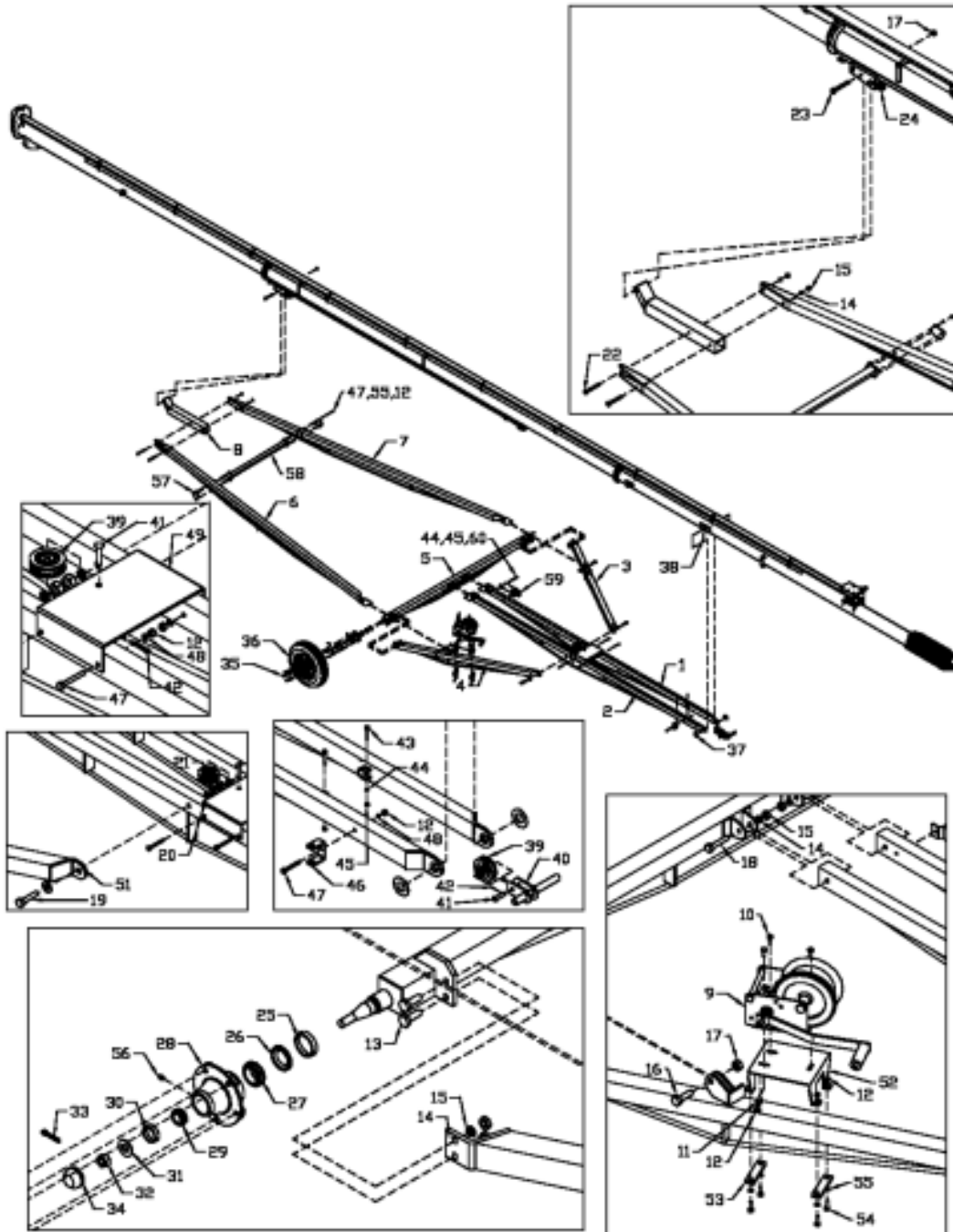

Item	Part Number	Description
1	F0718	L.H. Undercarriage Tube 183" Long (8" x 61')
	F0723	L.H. Undercarriage Tube 183" Long (10" x 61')
2	F8851	R.H. Undercarriage Tube 183" Long (8" x 61')
	F9933	R.H. Undercarriage Tube 183" Long (10" x 61')
3	962035	L.H. Cross Brace Tube 85-5/8" Long (8" x 61')
	962086	L.H. Cross Brace Tube 82-1/4" Long (10" x 61')
4	903416	R.H. Cross Brace Tube 85-5/8" Long (8" x 61')
	903417	R.H. Cross Brace Tube 82-1/4" Long (10" x 61')
5	962039	Axle 114" Long (8" x 61')
	962040	Axle 114" Long (10" x 61')
6	F8853	R.H. Lift Arm Tube 173" Long
7	F8852	L.H. Lift Arm Tube 173" Long
8	962043	Lift Arm Extension
9	961945	Winch
10	86170	3/8" x 1" Hex Bolt (pl)
11	84000	3/8" B.S. Flat Washer (pl)
12	81592	3/8" Hex Nut (pl)
13	84270	5/8" x 1-3/4" Hex Bolt (pl)
14	81677	5/8" Lock Washer (pl)
15	81676	5/8" Hex Nut (pl)
16	84346	3/4" x 2-1/2" Hex Bolt (pl)
17	812365	3/4" Lock Nut (pl)
18	81669	5/8" x 3-1/2" Hex Bolt (pl) (8" x 61')
	81672	5/8" x 4-1/2" Hex Bolt (pl) (10" x 61')
19	810149	3/4" x 3-1/2" Hex Bolt (pl)
	811790	3/4" x 4-1/2" Hex Bolt (pl) (10" x 61')
20	81701	3/4" Lock Washer (pl)
21	81700	3/4" Hex Nut (pl)
22	81674	5/8" x 5-1/2" Hex Bolt (pl)
23	84215	3/4" x 6" Hex Bolt (pl)
24	962044	Track Roller Assembly
25	968412	Inner Cup (LM48510)
26	968430	Oil Seal (SE14)
27	967208	Inner Cone (LM48548)
28	968403	Hub (5-Bolt W/Cups - H516)
	968431	H516 Hub Assembly
29	968406	Outer Cone (LM11949)
30	968405	Outer Cup (LM11910)
31	9812416	3/4" S.A.E. Flat Washer (br)
32	81834	3/4" Slotted Hex Nut (br)
33	9812486	1/8" x 1-1/2" Cotter Pin

Item	Part Number	Description
34	968409	Dust Cap (DC12)
35	968404	1/2" Wheel Bolt (pl)
36	F0110	Wheel 15" x 5" x 5-Bolt
37	967135	1-1/2" Rim Washer 10ga (pl)
38	967913	5/16" x 2-1/4" Cotter Pin (pl)
39	961846	3 1/2" Cast Cable Pulley w/ 1/2" Bore
40	961333	Pulley Holder (7" & 8")
	961334	Pulley Holder (10")
41	961010	1/2" x 2-1/8" Clevis Pin (pl)
42	9812430	1/8" x 1" Cotter Pin (pl)
43	810640	5/16" x 2" Hex Bolt (pl)
44	81569	5/16" Lock Washer (pl)
45	81568	5/16" Hex Nut (pl)
46	903392	Clevis Holder
47	81583	3/8" x 3" Hex Bolt (pl) (8")
	81587	3/8" x 4" Hex Bolt (pl) (10")
48	81637	1/2" Lock Washer (pl)
49	962060	Idler Mounting Plate (8")
	962064	Idler Mounting Plate (10")
51	81702	3/4" Flat Washer (pl)
52	903413	Winch Bracket 8-1/4" x 19-1/2"
53	903414	Connector Plate 3/8" x 1-1/4" x 5-1/2"
54	81546	3/8" x 1-1/4" Hex Bolt (pl)
55	81593	3/8" Lock Washer (pl)
56	967900	1/4" Grease Fitting
57	905152	X-Brace Plates 4" x 4-1/2"
58	905154	X-Brace Weldment 2" x 3" x 44-1/2"
59	909277	Manual Holder
60	812744	5/16" x 3-1/2" Hex Bolt (pl)

8" x 61' Bridging Assembly Drawing

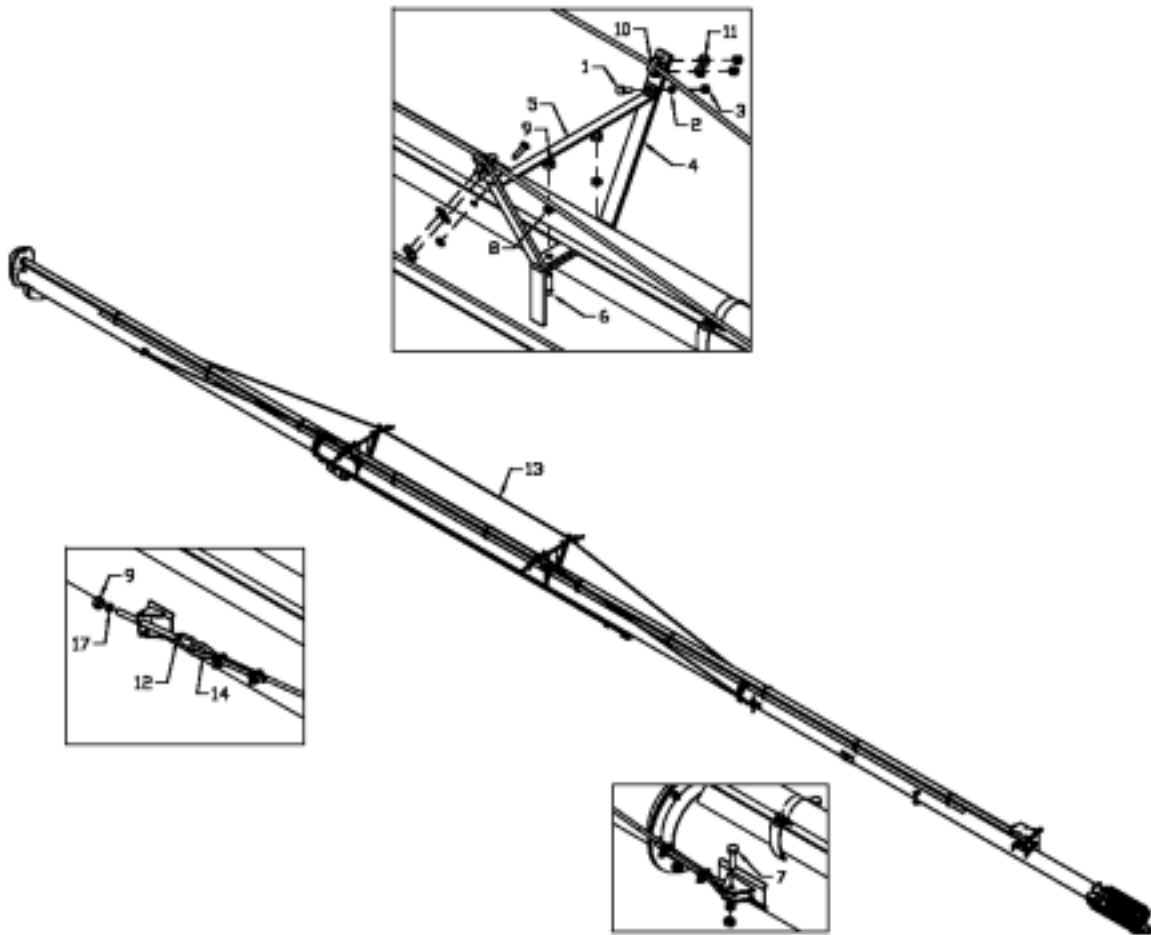

CA-22

10" x 61' Bridging Assembly Drawing

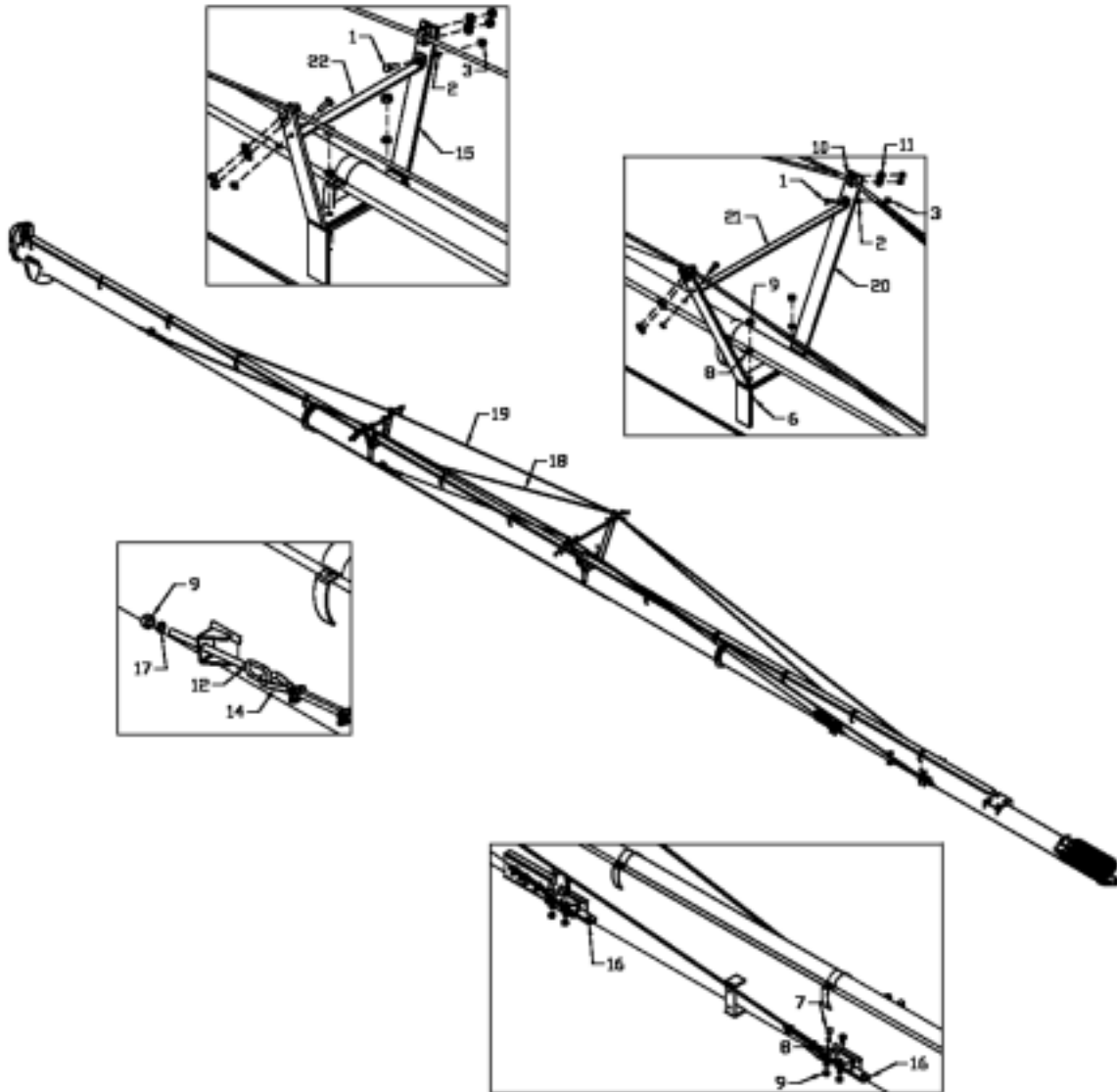

CA-23

Item	Part Number	Description
1	86171	3/8" x 1-1/4" Hex Bolt (pl)
2	81593	3/8" Lock Washer (pl)
3	81592	3/8" Hex Nut (pl)
4	F7027	Bridging Bracket Weldment
5	961532	Bridging Cross Brace
6	84277	1/2" x 1-1/2" Hex Bolt (pl)
7	811791	1/2" x 2" Hex Bolt (pl)
8	81637	1/2" Lock Washer (pl)
9	81636	1/2" Hex Nut (pl)
10	964264	3/8" Cable Clamps
11	964001	1" O.D. x .438" I.D. x 10ga Flat Washer (pl)
12	960031	Cable Tightener 1/2" x 7-7/8"
13	962047	Bridging Cable 3/8" x 37'-11" Assembled (8" x 61')
	962046	3/8" x 39'-7" Cable Only (8" x 61')
14	964267	3/8" Thimble
15	907054	Bridging Bracket Weldment
16	960244	Cable Yoke 1/4" x 1-1/2" x 10"
17	81638	1/2" B.S. Flat Washer (pl)
18	961265	Inner Cable 3/8" x 25' - 6" Lg Assembled (10" x 61')
	961266	3/8" x 27'-2" Cable Only (10" x 61')
19	962048	Outer Cable 3/8" x 43'- 7" Lg Assembled (10" x 61')
	962049	3/8" x 45'- 3" Cable Only (10" x 61')
20	961257	Bridging Yoke 62-1/2"
21	961258	Bridging Tie Bar 31"
22	902830	Bridging Tie Bar 18-3/16" Long

Cable Assembly Drawing

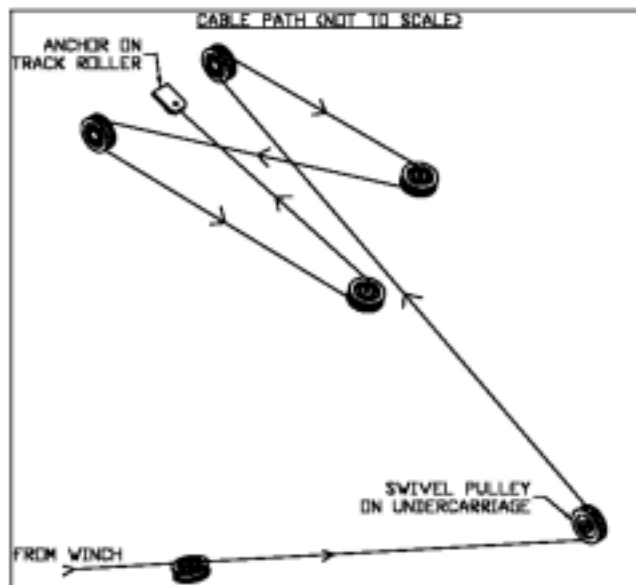
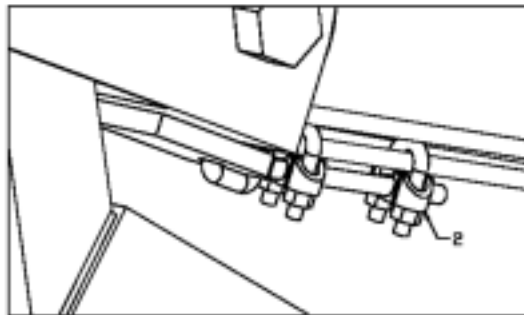
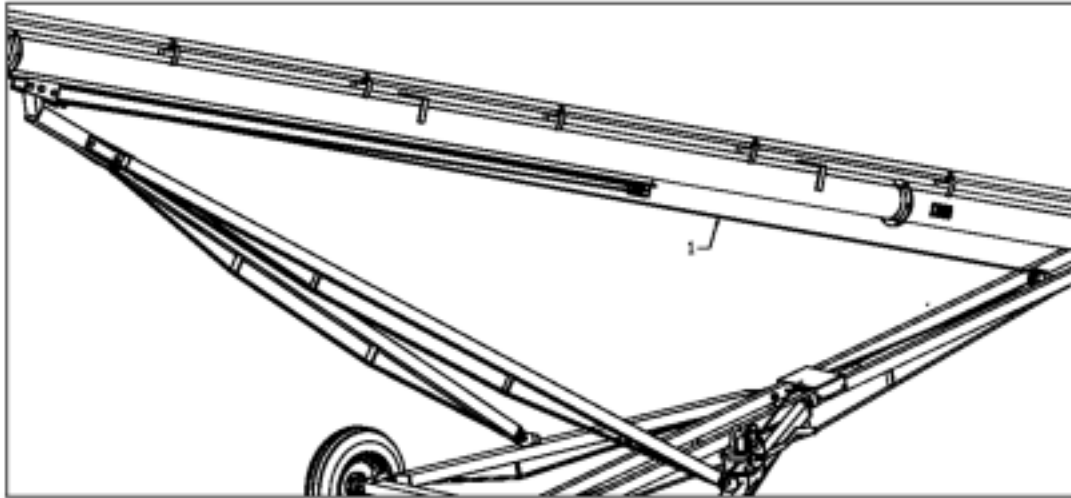

Item	Part Number	Description
1	962045	5/16" Cable 107' Long
2	961763	5/16" Cable Clamp

Direct Drive Assembly Drawing

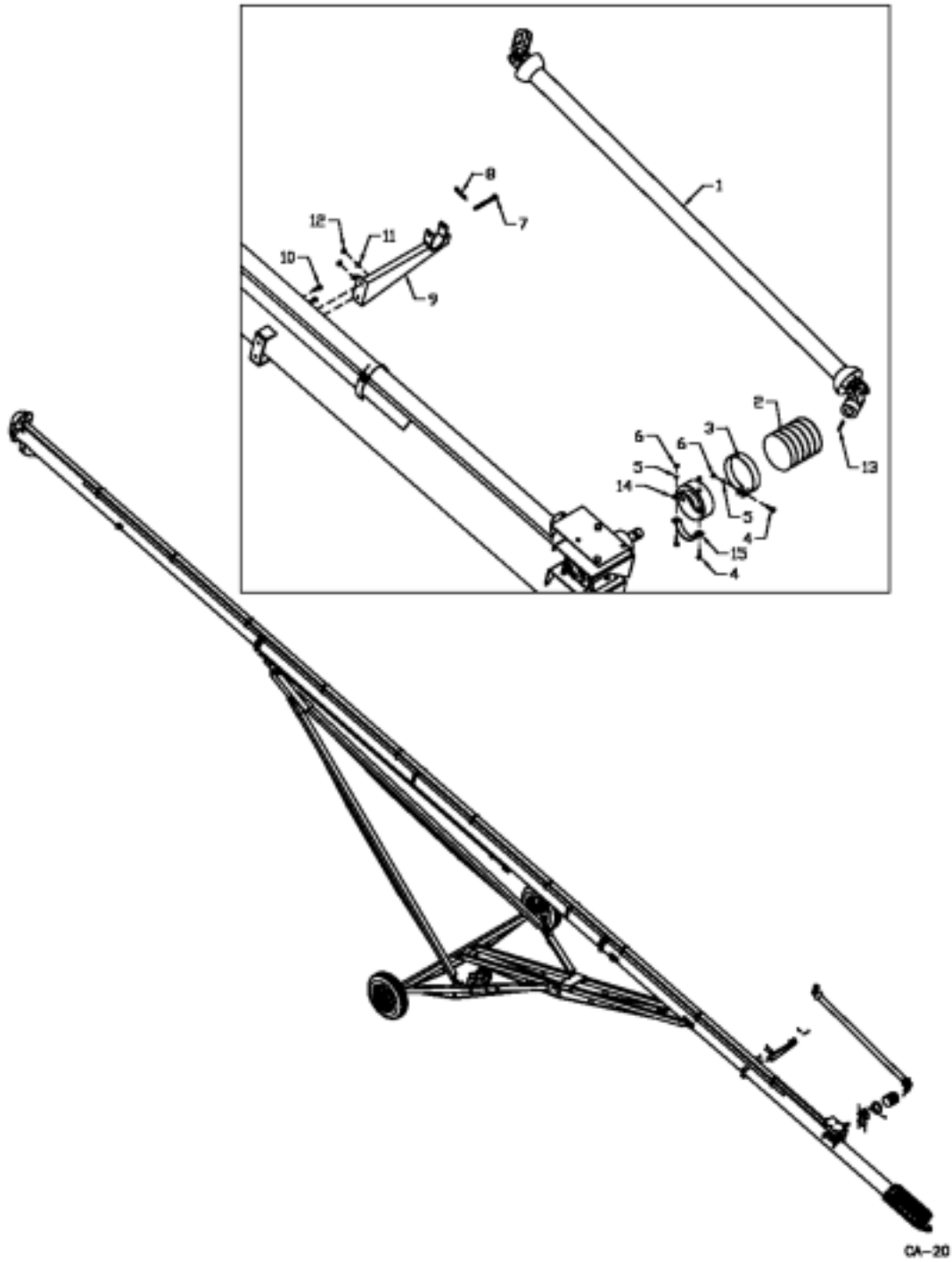

Item	Part Number	Description
1	F0466	8" & 10" PTO Shaft
2	961201	6" Plastic Tube 6-1/2" Long
3	961200	6 1/4" x 1-1/4" Guard Clamp
4	81553	5/16" x 1-1/4" Hex Bolt (pl)
5	81569	5/16" Lock Washer (pl)
6	81568	5/16" Hex Nut (pl)
7	961539	3/8" x 4-1/2" Pin
8	12780	#7 Hair Pin Clip
9	961790	PTO Hanger
10	86170	3/8" x 1" Hex Bolt (pl)
11	81593	3/8" Lock Washer (pl)
12	81592	3/8" Hex Nut (pl)
13	968807	3/8" x 3/8" x 2" Key
14	961202	PTO Guard Holder w/ 4" I.D. Clamp
15	961896	4" I.D. Clamp

Clamp-on Motor Mount Assembly Drawing

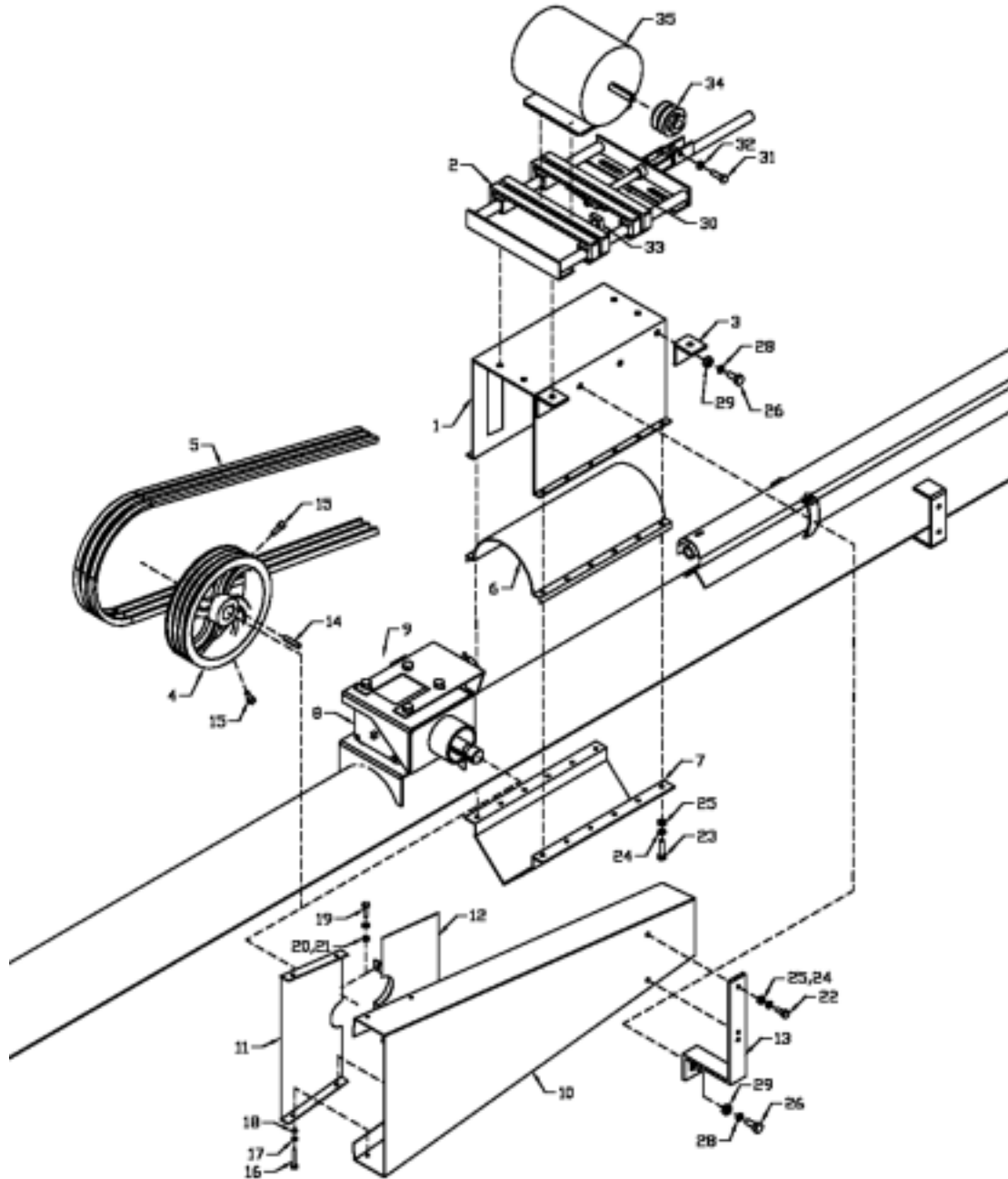

CA-24

Item	Part Number	Description
1	961196	8" Motor Mount Stand
	961184	10" Motor Mount Stand
2	907360	Motor Mount Weldment
	907361	Motor Mount Assembly
3	961186	Angle Iron
4	961187	12" Triple Sheave (1-1/2" bore)
5	973417	B-83 V-Belt (3 required)
6	961164	8" Round Clamp
	961191	10" Round Clamp
7	961165	8" V-Clamp
	961192	10" V-Clamp
8	BU50510	Gearbox
	907207	Gearbox (1061 BD)
	961086	Reverse Shift Gearbox (Optional)
	907413	Reverse Shift Gearbox (Optional 1061 BD)
9	906093	Gearbox Plate
10	F1871	Belt Guard (42-1/2" long)
11	961157	10" Bolt-on Guard Insert
12	961158	10" Clamp-on Guard Insert
13	961162	Guard Bracket (21" long)
14	968807	3/8" sq. x 1-1/2" key
15	81213	3/8" x 1" Sq. Hd. Set Screw
16	81525	1/4" x 3/4" Hex Bolt
17	81545	1/4" Lock Washer
18	81544	1/4" Hex Nut
19	81552	5/16" x 1-1/4" Hex Bolt
20	81569	5/16" Lock Washer
21	81568	5/16" Hex Nut
22	86170	3/8" x 1" Hex Bolt
23	81578	3/8" x 1-3/4" Hex Bolt
24	81593	3/8" Lock Washer
25	81592	3/8" Hex Nut
26	81620	1/2" x 1-1/4" Hex Bolt
27	81638	1/2" Flat Washer
28	81637	1/2" Lock Washer
29	81636	1/2" Hex Nut
30	961973	12" Adjusting Rod
31	981601	7/16" x 2" Hex Bolt
32	86273	7/16" Lock Nut
33	811852	3/4" Square Nut (pl)
34*		Motor Sheave (Supplied by customer)
35*		Electric Motor (Supplied by customer)

*See instructions for correct Sheave and Motor sizes on next page.

Clamp-on Motor Mount Kit Instructions

1. All 61' augers are supplied with direct drive only. Bolt the motor mount stand (#1) and the two clamps (#6) and (#7) together on the tube with 3/8" x 1-3/4" cap screws, lock washers and hex nuts. Bolt the two angle irons (#3) to the side of the stand so they are flush with the top of the stand.



ALERT

The angle irons and the two extra holes on the side of the stand near the center must be on the same side as the guard.

2. Bolt the electric motor (#34) to the motor mount and mount a triple sheave (both supplied by customer). Do not tighten bolts until both sheaves are aligned. The electric motor must be a 1725 rpm. Motor sizes are: 8" x 61' - 15 H.P. 10" x 61' - 20 H.P. Pulley size: 3-1/2" for 8" & 10".
3. Mount the 12" triple sheave on the gearbox using key and set screws supplied. After aligning the two sheaves with the auger tube, tighten motor mount bolts and pulley set screws. Mount belts on the sheaves. The motor mount handle acts as a belt tightener.
4. Bolt the guard insert (#11) to the belt guard (#10) using 1/4" x 3/4" cap screws, lock washers and hex nuts. The guard assembly is then clamped to the ring on the gearbox plate using clamp (#12) and 5/16" x 1-1/4" cap screws, lock washers and hex nuts.

The other end of the guard is held on by a guard bracket (#13) which bolts to the guard using 3/8" x 1" bolts and to the motor mount stand (#1) using a 1/2" x 1-1/4" bolt. Center the guard on the motor sheave before tightening guard.

Winch Drawing

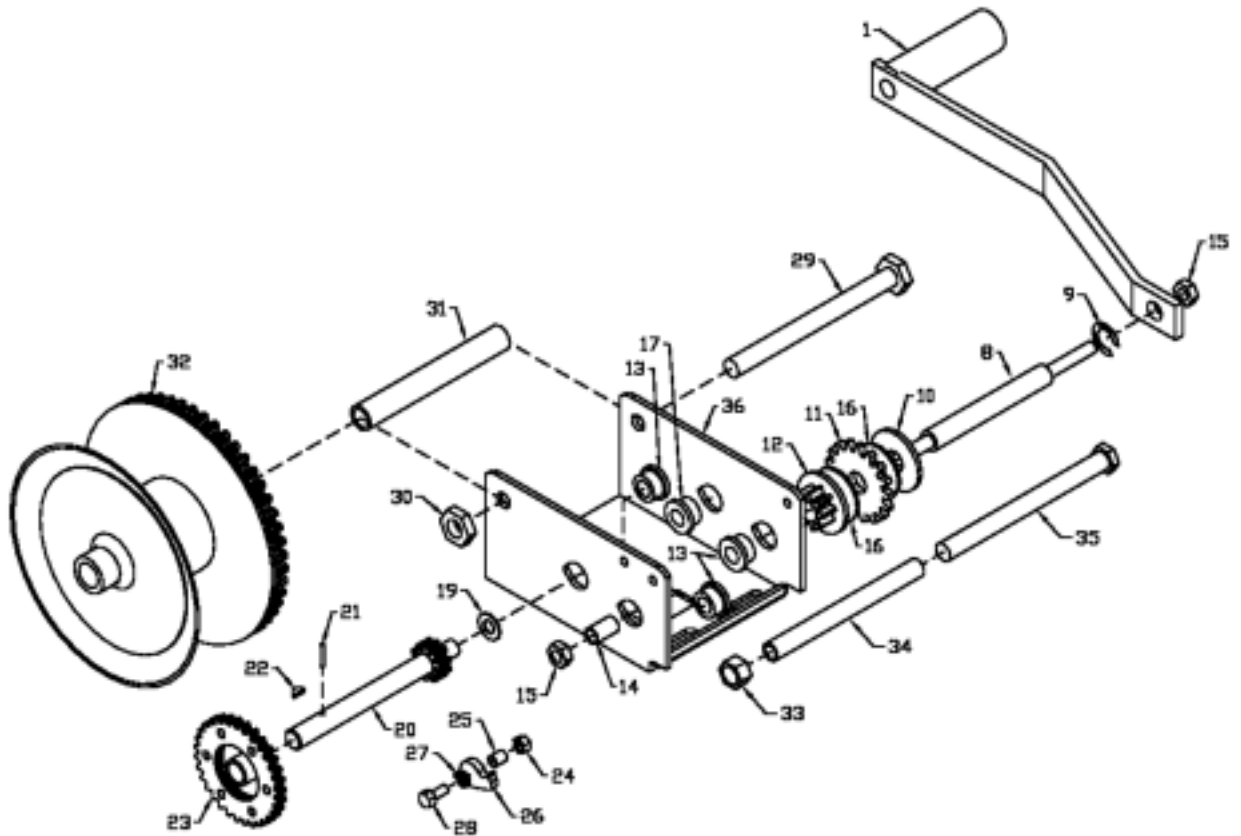

CA-28

Item	Part Number	Description
1	2461S01	Handle
	5621S01	Cable Keeper Kit
4		Bolt
5		Cable Clamp
6		Lockwasher
7		Nut
	1565S01	Input Shaft Kit
8		Input Shaft
9		Retaining Ring
10		Brake Disc
11		Ratchet Gear
12		Pinion Gear
13		Bushing
14		Spacer
15		Nut
16	1578S00	Friction Disc
	1569S01	Intermediate Shaft Kit
17		Bushing
19		Washer
20		Intermediate Shaft
21		Roll Pin
22		Woodruff Key
23		Gear
	6730S00	Ratchet Kit
24		Nut
25		Spacer
26		Ratchet Pawl
27		Spring
28		Shoulder Bolt

Item	Part Number	Description
29*		Drum Bolt
30*		Lock Nut
31*		Drum Spacer
32*		Drum Assembly
33*		Lock Nut
34*		Frame Spacer
35*		Bolt
36*		Frame
	906537	Bushing Kit
13		Bushing
17		Bushing

*Not available

PTO Assembly Drawing

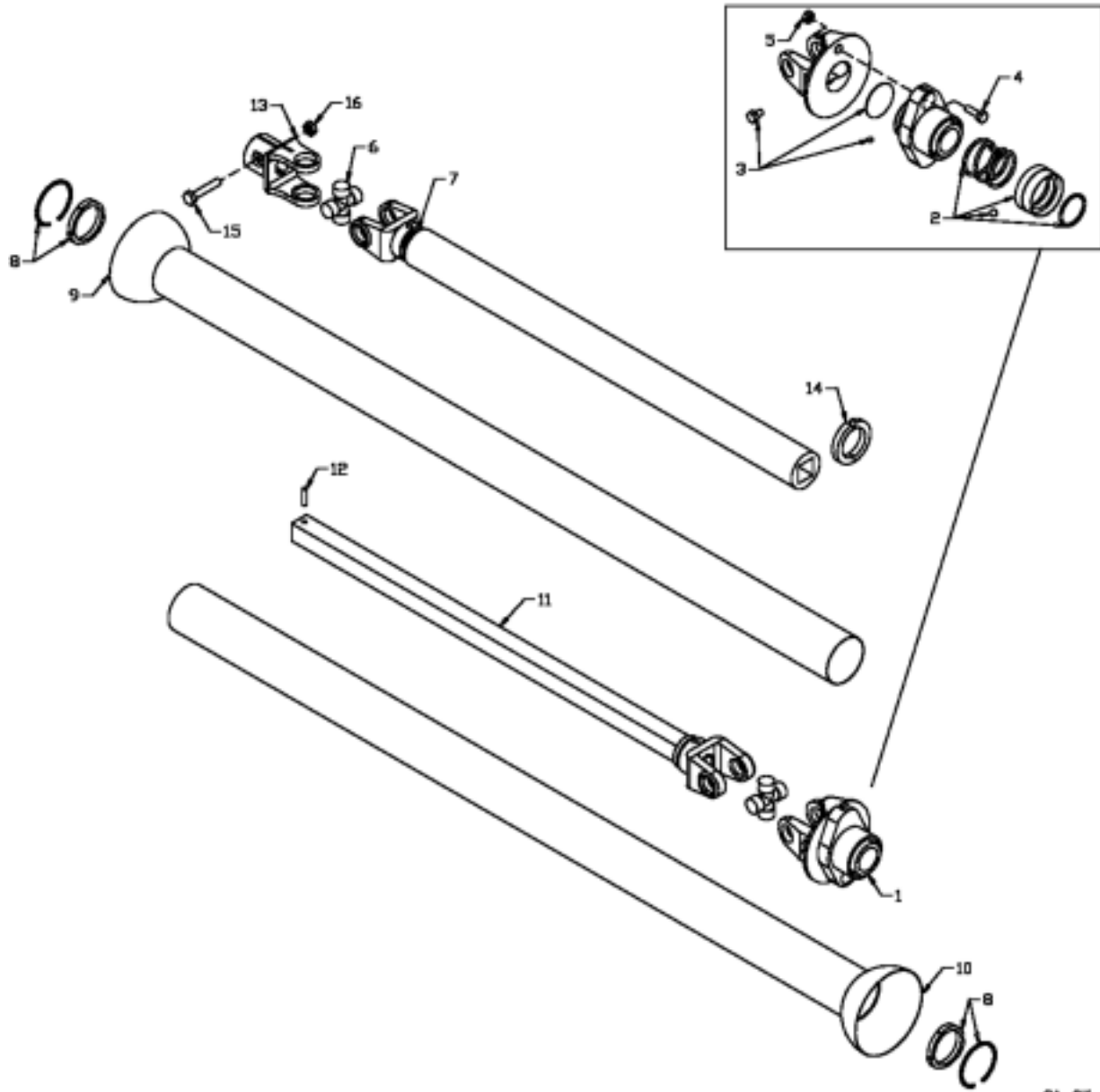

Item	Part Number	Description
	F0466	Shaft Complete
	908960	Tractor Half of PTO (Shear)
	908958	Implement Half of PTO
1	936324	Shear Assembly
2	936168	Spring-Lok Repair Kit (Collar, Spring, Ret. Ring, 2 - 3/8" Balls)
3	936248	Shear Assembly Repair Kit (3/8" x 1/2" Bolt, Grade 5 - One Required)
4	86170	3/8" x 1" Shear Bolt, Grade 5 - One Required
5	812363	3/8" Lock Nut
6	936093	Repair Kit
7	936325	Yoke & Tube
8	936320	Nylon Bearing Repair Kit
9	908956	Inner Guard
10	907397	Outer Guard
11	936329	Yoke & Shaft
12	936315	1/4" x 1" Roll Pin
13	936376	Clamp Yoke
14	936316	Shield Bearing
15	81628	1/2" x 3-1/4" Hex Bolt
16	812364	1/2" Lock Nut

Gearbox Drawing

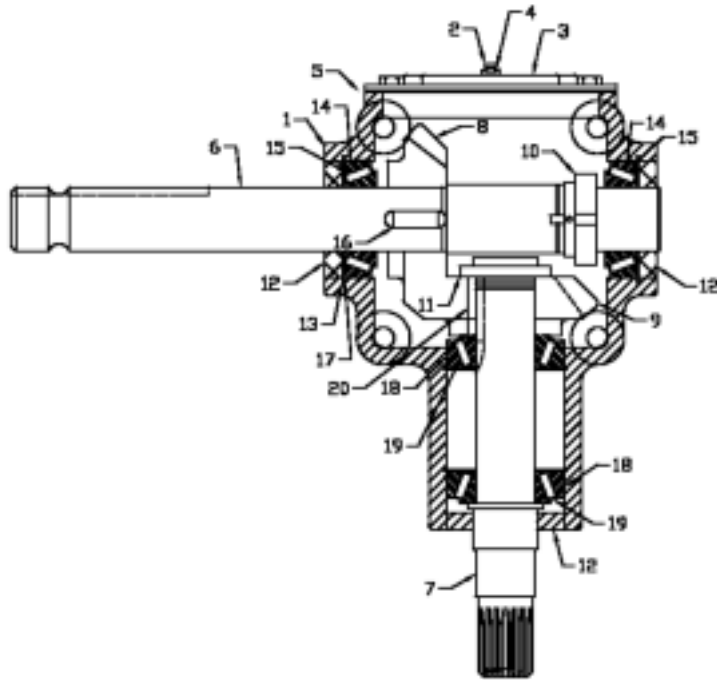

CA-29

Item	Part Number	Description
	BU50510	Gearbox Complete
1	BU50310	Gearbox Casting Only
2	BU500089-3	Pipe Plug
3	BU50457	Gearbox Cover
4	BU500167-1	Relief Valve
5	BU50458	Gearbox Gasket
6	BU50509	Cross Shaft
7	BU50502	Pinion Shaft
8	BU50329	Bevel Gear 1-1/2" B
9	BU50331	Bevel Gear 1-3/8" B
10	BU50428	Adjusting Nut
11	BU50444	Adjusting Nut
12	BU50422-1	Oil Seal (3 Used)
13	BU50415	Retainer Ring (4 Used)
14	BU575902	Bearing Cup (2 Used)
15	BU575901	Bearing Cone (2 Used)
16	BU50429	Key
17	BU50210X	Shim Set
18	BU575907	Bearing Cup (2 Used)
19	BU575906	Bearing Cone (2 Used)
20	BU50417-1	Key

Reverse Gearbox Drawing

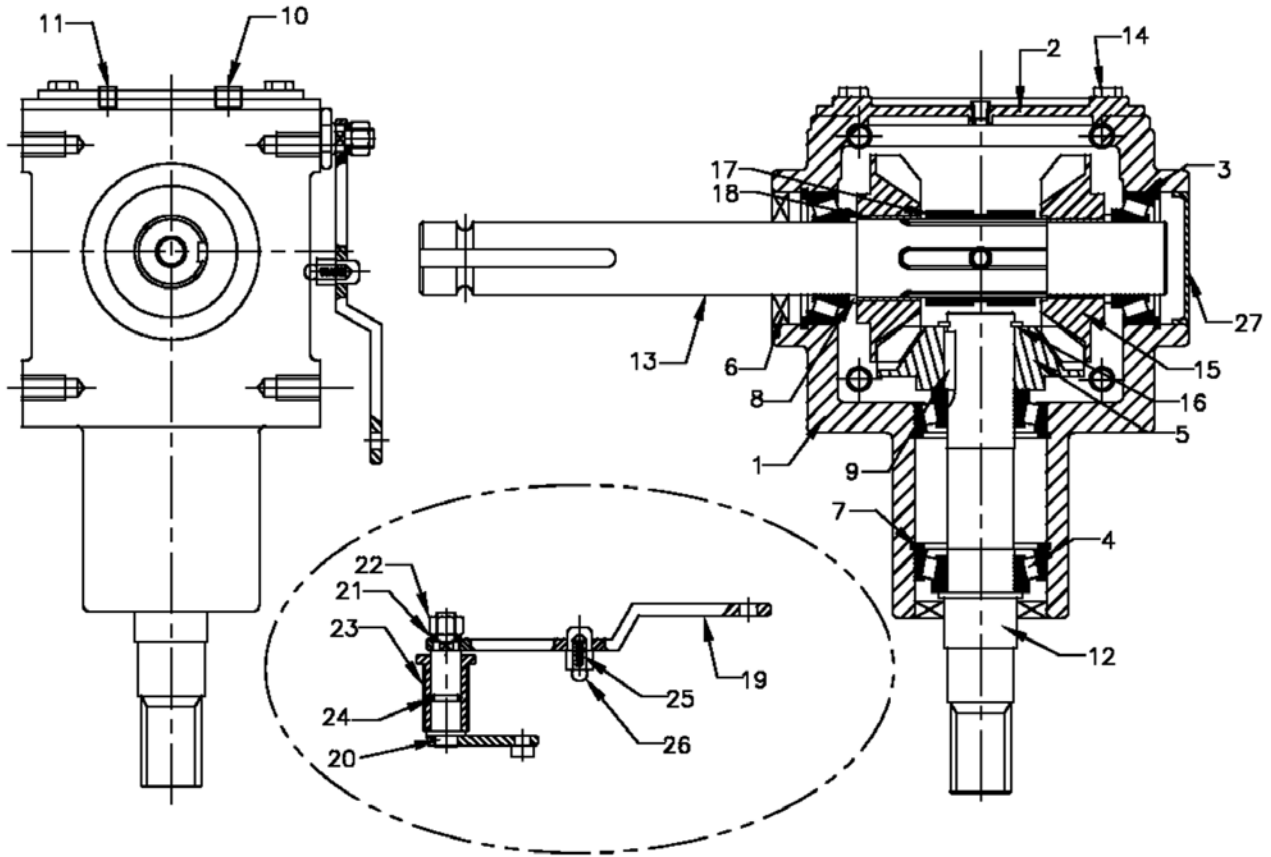

CA-31

Item	Part Number	Description
	961086	Gearbox Complete
1	906690	Case
2	906691	End Cap
3	906692	Bearing (13620 & 13687)
4	906693	Bearing (14276 & 14137)
5	906694	Gear
6	906695	Seal
7	906696	Snap Ring
8	906697	Shim
9	906698	Key
10	906699	ZG 1/8" - 27 Vent Plug
11	906700	3/8" NPT Solid Plug
12	906701	Output Shaft
13	906702	Input Shaft
14	906703	Bolt 5/16" UNC x 3/4"
15	906704	Gears
16	906705	Snap Ring
17	906706	Dog
18	906707	Bronze Bushes
19-26	906708	Complete Lever Assembly
27	907453	Stamping Cap

Belt Drive Gearbox Drawing

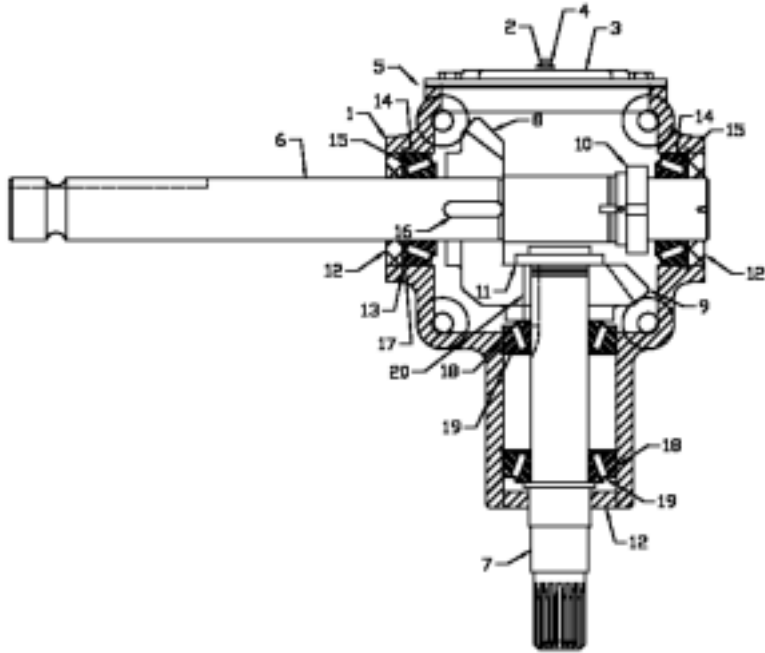

CA-38

Item	Part Number	Description
	907207	Gearbox Complete
1	BU50310	Gearbox Casting Only
2	BU500089-3	Pipe Plug
3	BU50457	Gearbox Cover
4	BU500167-1	Relief Valve
5	BU50458	Gearbox Gasket
6	24970	Cross Shaft
7	BU50502	Pinion Shaft
8	BU50329	Bevel Gear 1-1/2" B
9	BU50331	Bevel Gear 1-3/8" B
10	BU50428	Adjusting Nut
11	BU50444	Adjusting Nut
12	BU50422-1	Oil Seal (3 Used)
13	BU50415	Retainer Ring (4 Used)
14	BU575902	Bearing Cup (2 Used)
15	BU575901	Bearing Cone (2 Used)
16	BU50429	Key
17	BU50210X	Shim Set
18	BU575907	Bearing Cup (2 Used)
19	BU575906	Bearing Cone (2 Used)
20	BU50417-1	Key

Reverse Shift Belt Drive Gearbox Drawing

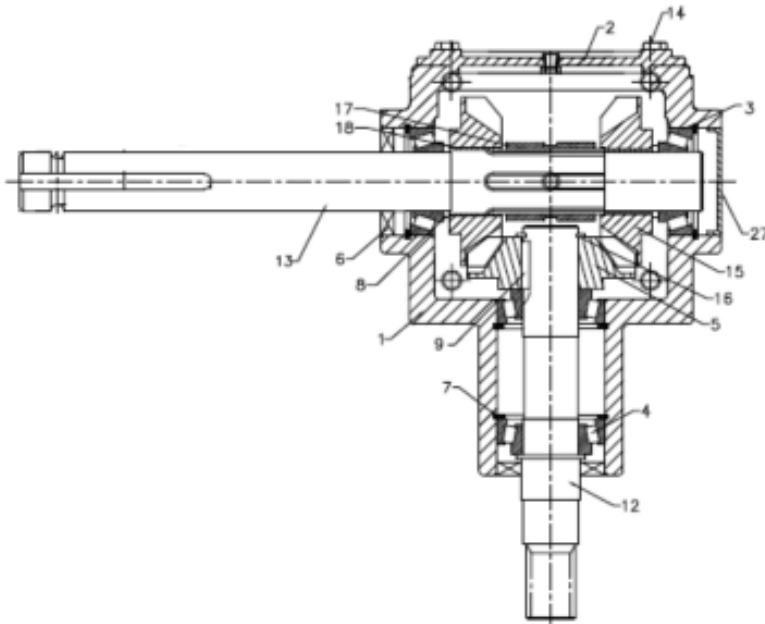

Item	Part Number	Description
1	986-01	Case
2	986-02	End Cap
3	986-03	Bearing (13620 & 13687)
4	986-04	Bearing (14276 & 14137)
5	986-05	Gear
6	986-06	Seal
7	986-07	Snap Ring
8	986-08	Shim
9	986-09	Key
10	986-10	ZG 1/8"- 27 Vent Plug
11	986-11	3/8" NPT Solid Plug
12	986-12	Output Shaft
13	ES1-10124	Input Shaft
14	986-14	Bolt 5/16" UNC x 3/4"
15	986-15	Geers
16	986-16	Snap Ring
17	986-17	Dog
18	986-18	Bronze Bushes
19	986-19	Shifter Lever
20	986-20	Shifter Mechanism
21	986-21	Shim Kit (10.3 x 21 x 1.5)
22	986-22	Nut M10
23	986-23	Screw Thread Bushing
24	986-24	O-Ring
25	986-25	Spring
26	986-26	Steel Ball (0.315)
27	986-27	Stamping Cap

Shipping Kit and Bundle Numbers

The following is a list of Kit Numbers for this product and the Bundle Numbers, Descriptions, and Quantities for each Kit.

Quantity	Bundle Number	Description
----------	---------------	-------------

C861D - 8" x 61' Direct Drive Auger		
1	F0654	Top Section Tube
1	F0653	Center Section Tube
1	F0652	Bottom Section Tube
1	F0718	L.H. Undercarriage Arm
1	F8851	R.H. Undercarriage Arm
1	F8852	L.H. Lift Arm
1	F8853	R.H. Lift Arm
1	F8854	Axle
1	F0699	Undercarriage X-Brace
1	F0700	Crate of Parts

C1061D - 10" x 61' Direct Drive Auger		
1	F9515	Bridging
1	F9929	Top Section Tube
1	F9930	Center Section Tube
1	F9931	Bottom Section Tube
1	F0723	L.H. Undercarriage Arm
1	F9933	R.H. Undercarriage Arm
1	F8852	L.H. Lift Arm
1	F8853	R.H. Lift Arm
1	F9936	Axle
1	F0698	Undercarriage X-Brace
1	F0702	Crate of Parts

Quantity	Bundle Number	Description
C1061E - 10" x 61' Four-Belt Engine Drive Auger		
1	F9515	Bridging
1	F0943	Top Section Tube
1	F9930	Center Section Tube
1	F0941	Bottom Section Tube
1	F0723	L.H. Undercarriage Arm
1	F9933	R.H. Undercarriage Arm
1	F8852	L.H. Lift Arm
1	F8853	R.H. Lift Arm
1	F9936	Axle
1	F8909	X-Tube Bundle
1	F0942	Belt Guard Bundle
1	F0945	Outer Tightener Tube
1	F0944	Crate of Parts

Optional Bundle Numbers

The following is a list of options available for the Kits listed above.

Quantity	Bundle Number	Description
1	F3005	13" Poly Spout
1	F211	Big Daddy Flex Hopper
1	F001	Safety Light Kit
1	F0013	Reflective Safety Decal Kit
1	Y0029	Light Kit

Farm King Limited Warranty

This document limits your warranty rights.

Base Limited Warranty

Buhler Industries Inc. provides this warranty only to original retail purchasers of its product. Buhler Industries Inc. warrants to such purchasers that all Buhler Industries Inc. manufactured parts and components used and serviced as provided for in the Operator's Manual shall be free from defects in materials and workmanship for a period following delivery to the original retail purchaser of 12 months (80 days for commercial applications). This limited warranty applies only to those parts and components manufactured by Buhler Industries Inc. Parts and components manufactured by others are subject to their manufacturer's warranties, if any.

Buhler Industries Inc. will fulfill this limited warranty by, at its option, repairing or replacing any covered part that is defective or is the result of improper workmanship, provided that the part is returned to Buhler Industries Inc. within thirty (30) days of the date that such defect or improper workmanship is, or should have been, discovered. Buhler Industries Inc. reserves the right to either inspect the product at the buyer's location or have it returned to the factory for inspection. Parts must be returned through the selling representative and the buyer must prepay transportation charges.

Buhler Industries Inc. will not be responsible for repairs or replacements that are necessitated, in whole or part, by the use of parts not manufactured by or obtained from Buhler Industries Inc. Under no circumstances are component parts warranted against normal wear and tear. There is no warranty on product pump seals, product pump bearings, rubber product hoses, pressure gauges, or other components that require replacement as part of normal maintenance. Also: Buckets and Bucket Tines carry no warranty, Bent Spears carry no warranty, Snowblower Fan Shafts carry no warranty, Mower Blades carry no warranty, Portable Auger Parts Have Two (2) Year Warranty, Loader Parts Have Two (2) Year Warranty. The purchaser is solely responsible for determining suitability of goods sold. This warranty is expressly in lieu of all other warranties expressed or implied. Buhler Industries Inc. will in no event be liable for any incidental or consequential damages whatsoever. Nor for any sum in excess of the price received for the goods for which liability is claimed.

Repair Parts Limited Warranty

Buhler Industries Inc. warrants Farm King replacement parts purchased after the expiration of the Buhler Industries Inc. Limited Warranty, and used and serviced as provided for in the Operator's Manual, to be free from defects in materials or workmanship for a period of thirty (30) days from the invoice date for the parts. Buhler Industries Inc. will fulfill this limited warranty by, at its option, repairing or replacing any covered part that is defective or is the result of improper workmanship, provided that the part is returned to Buhler Industries Inc. within thirty (30) days of the date that such defect or improper workmanship is, or should have been, discovered. Such parts must be shipped to Buhler Industries Inc. at the purchaser's expense.

What is Not Covered

Under no circumstances does this limited warranty cover any components or parts that have been subject to the following: negligence; alteration or modification not approved by Buhler Industries Inc.; misuse; improper storage; lack of reasonable and proper maintenance, service, or repair; normal wear; damage from failure to follow operating instructions; accident; and/or repairs that have been made with parts other than those manufactured, supplied, and or authorized by Buhler Industries Inc.

Authorized Dealer and Labor Costs

Repairs eligible for labor under this limited warranty must be made by Buhler Industries Inc. or an authorized Farm King dealer. Buhler Industries Inc. retains the exclusive discretion to determine whether it will pay labor costs for warranty repairs or replacements, and the amount of such costs that it will pay and the time in which the repairs will be made. If Buhler Industries Inc. determines that it will pay labor costs for warranty work, it will do so by issuing a credit to the dealer's or distributor's account. Buhler Industries Inc. will not approve or pay invoices sent for repairs that Buhler Industries Inc. has not previously approved. Warranty service does not extend the original term of this limited warranty.

Warranty Requirements

To be covered by warranty, each Farm King new product must be registered with Buhler Industries Inc. within thirty (30) days of delivery to original retail purchaser. If the customer decides to purchase replacement components before the warranty disposition of such components is determined, Buhler Industries Inc. will bill the customer for such components and then credit the replacement invoice for those components later determined to be covered by this limited warranty. Any such replacement components that are determined not be covered by this limited warranty will be subject to the terms of the invoice and shall be paid for by the purchaser.

Warranty Claims:

Warranty requests must be prepared on Buhler Industries Inc. Warranty Claim Forms with all requested information properly completed. Warranty Claims must be submitted within a thirty (30) day period from date of failure repair.

Warranty Labor:

Any labor subject to warranty must be authorized by Buhler Industries Inc. The labor rate for replacing defective parts, where applicable, will be credited at 100% of the dealer's posted shop rate.

Exclusive Effect of Warranty and Limitation of Liability

TO THE EXTENT PERMITTED BY LAW, BUHLER INDUSTRIES INC. DISCLAIMS ANY WARRANTIES, REPRESENTATIONS, OR PROMISES, EXPRESS OR IMPLIED, AS TO THE QUALITY, PERFORMANCE, OR FREEDOM FROM DEFECT OF THE COMPONENTS AND PARTS COVERED BY THIS WARRANTY AND NOT SPECIFICALLY PROVIDED FOR HEREIN.

TO THE EXTENT PERMITTED BY LAW, BUHLER INDUSTRIES INC. DISCLAIMS ANY IMPLIED WARRANTIES OF MERCHANTABILITY AND FITNESS FOR A PARTICULAR PURPOSE ON ITS PRODUCTS COVERED HEREIN, AND DISCLAIMS ANY RELIANCE BY THE PURCHASER ON BUHLER INDUSTRIES INC.'S SKILL OR JUDGMENT TO SELECT OR FURNISH GOODS FOR ANY PARTICULAR PURPOSE. THE PURCHASER'S ONLY AND EXCLUSIVE REMEDIES IN CONNECTION WITH THE BREACH OR PERFORMANCE OF ANY WARRANTY ON PRODUCTS MANUFACTURED BY BUHLER INDUSTRIES INC. ARE THOSE SET FORTH HEREIN. IN NO EVENT SHALL BUHLER INDUSTRIES INC. BE LIABLE FOR INCIDENTAL OR CONSEQUENTIAL DAMAGES (INCLUDING, BY WAY OF EXAMPLE ONLY AND NOT LIMITATION, LOSS OF CROPS, LOSS OF PROFITS OR REVENUE, OTHER COMMERCIAL LOSSES, INCONVENIENCE, OR COST OF REPLACEMENT OF RENTAL EQUIPMENT). IN NO EVENT SHALL FARM KING'S CONTRACT OR WARRANTY LIABILITY EXCEED THE PURCHASE PRICE OF THE PRODUCT.

(Note that some provinces or states do not allow limitations on how long an implied warranty lasts or the exclusion or limitation of incidental or consequential damages, so the above limitations and exclusion may not apply to you.) This warranty gives you specific legal rights and you may also have other rights, which vary from province to province or state to state.

Buhler Industries Inc. neither assumes nor authorizes any person or entity, including its selling representatives, to assume any other obligations or liability in connections with the sale of covered equipment, or to make any other warranties, representations, or promises, express or implied, as to the quality, performance, or freedom from defect of the components and parts covered herein. No one is authorized to alter, modify, or enlarge this limited warranty, or its exclusions, limitations and reservations.

Corrections of defects and improper workmanship in the manner, and for the applicable time periods, provided for herein shall constitute fulfillment of all responsibilities of Buhler Industries Inc. to the purchaser, and Buhler Industries Inc. shall not be liable in negligence, contract, or on any other basis with respect to the subject equipment.

This limited warranty is subject to any existing conditions of supply which may directly affect Buhler Industries Inc.'s ability to obtain materials or manufacture replacement parts.

Buhler Industries Inc. reserves the right to make improvements in design or changes in specifications to its products at anytime, without incurring any obligation to owners of units previously sold.

Government Legislation:

Warranty terms and conditions are subject to provincial or state legislation.

Important Note: This warranty does not apply to rentals.

www.farm-king.com

Farm King

301 Mountain Street South
Morden, Manitoba Canada R6M 1X7
Ph.: 204.822.4467 | Fax: 204.822.6348
Toll Free: 888.524.1004
E-mail: info@buhler.com
www.farm-king.com

Equipment shown is subject to change without notice.
©2010 Buhler Trading Inc. Printed in USA. TSX:BUI

bühler | a division of Buhler Industries Inc.