



# STEIGER® & MAGNUM™

SERIES SCRAPER EDITION TRACTORS



STEIGER & MAGNUM SERIES SCRAPER EDITION TRACTORS

**CASE II**

**CASE II**



## STEIGER® & MAGNUM™

6 Steiger Tractor Models | 370–620 Rated Engine HP  
10 Magnum Tractor Models | 180–400 Rated Engine HP

### PROVEN WORKHORSES ON CONSTRUCTION SITES, MOVING EARTH AT THE LOWEST POSSIBLE COST PER YARD

Jobs keep getting bigger, with shorter deadlines and in tougher conditions. The whole time, you're asked to do more with less. You can always depend on Case IH tractors to pull their weight — and then some. Our patented SCR-only Tier 4B/Final emissions systems provide a unique combination of power and fuel efficiency. We designed our cabs and controls to help you get the most from long days. You get a lower cost per yard on the job site and reliable performance in every condition. Proven and field-tested throughout the lineup, Case IH tractors help improve your bottom line and ensure you're prepared for the challenges ahead.

“I like how the Steigers are also really narrow, so when we're hauling them, they're not hanging off the semis by two feet.”

Clayton Fechko, Medina, Ohio



**STEIGER & MAGNUM SERIES SCRAPER EDITION TRACTORS**

Serious Earthmoving Power . . . . . 4–9

Case IH FPT Engines . . . . . 10

Time-Tested Tier 4 Technology . . . . . 11

Productivity and Serviceability . . . . . 12–13

A Choice of Transmissions. . . . . 14–19

Productivity, Connectivity and Profitability . . . . . 20–21

Built to Work in the Dirt . . . . . 22–25

Work Smarter and in Comfort. . . . . 26–29

Legendary Steiger Power . . . . . 30–33

Class-Leading Magnum Power . . . . . 34–37

Support . . . . . 38

Specifications . . . . . 39–43



# POWER TO MATCH ANY SCRAPER

SCRAPER SIZE	TRACTOR SIZE*
8 yard	Magnum 180
10 yard	Magnum 200, 240
12 yard	Magnum 250, 280, 310
15 yard	Magnum 310, 340, 380 & Steiger 370, 420
16 yard	Magnum 340, 380 & Steiger 370, 420
17 yard	Steiger 420, 470, 500
18 yard +	Steiger 500, 540, 580, 620 (Commercial Scraper Models)

\*Model number is Rated HP. See specs for RPMs.

Construction managers now know what farmers have known for decades: **Case IH Steiger and Magnum tractors have the power you need to get the job done.** No matter your scraper needs, we have a tractor that will fit your operation.

### A GOOD RULE OF THUMB TO DETERMINE THE NEEDED ENGINE HP:

Each cubic yard takes about 18 HP. If pulling dual pans, it takes about 27 HP per cubic yard. Please note specific soil type and terrain may affect HP requirements. Work with your Case IH dealer to find your perfect match.





# STEIGER SERIES TRACTORS

STEIGER SCRAPER MODELS 370/420/470/  
500/540/580/620 | 370-620 ENGINE HP\*

With industry-leading peak horsepower and record-setting fuel efficiency, Steiger tractors tackle large-scale dirt work to help your fleet achieve maximum productivity.

## STANDARD FEATURES:

- 8.7L engine (370)
- 12.9L engine (420, 470, 500, 540, 580, 620)
- Engine Compression Brake
- PowerDrive Power Shift Transmission (370, 420, 470, 500, 540, 580, 620)
- Four standard hydraulic remotes
- 4-point cab suspension system

## OPTIONAL FEATURES:

- CVXDrive (370, 420, 470, 500, 540)

## OPTIONAL CONFIGURATIONS:

- Wheeled (All Models)
- Quadtrac® (470, 500, 540, 580, 620)
- Scraper Configuration (500W, 540W, 540QT, 580W, 580QT, 620W)



\*See specs for details.







# MAGNUM SERIES TRACTORS

MAGNUM MODELS 180/200/220/240/250/  
280/310/340/380/400 | 180–400 ENGINE HP\*

Magnum models are easily configurable to handle heavier load demands in scraper operations.

## STANDARD FEATURES:

- Up to 14% power growth
- Efficiently pull scrapers at speeds above 4 mph
- 4-point suspended cab
- Suspended axles
- Up to 435 peak HP
- Engine Compression Brake (250, 280, 310, 340, 380, 400)

## ENGINE OPTIONS:

- 6.7L engine (180, 200, 220, 240)
- 8.7L engine (250, 280, 310, 340, 380, 400)

## OPTIONAL FEATURES:

- PowerDrive Power Shift Transmission (180, 200, 220, 250, 280, 310, 340, 400)
- CVXDrive (180, 200, 220, 240, 250, 280, 310, 340, 380)



\*See specs for details.

# INDUSTRY-LEADING POWER AND PERFORMANCE CARED FOR BY CASE IH EXPERTS

Case IH Tier 4 B/Final engines by FPT — featuring common rail fuel systems and a patented Case IH FPT SCR-only emissions system — offer power, performance and fuel economy with no active exhaust cleaning required. They also deliver more low-end torque to allow the engine to lug down and recover more quickly.

## POWERFUL

- 6.7L, 8.7L and 12.9L engines with FPT technology provide leading fuel efficiency while maximizing power.
- **Up to 10% power growth** to maximize performance in the toughest conditions.
- Steiger 540, 580 and 620 models feature a two-stage turbocharger system with separate cooling system, delivering 40% faster response under load.

## EFFICIENT

- Patented Selective Catalytic Reduction (SCR) meets Tier 4 B-Final emission standards without compromising engine performance.
- Does not require additional emission components such as Diesel Particulate Filter (DPF) and Cooled Exhaust Gas Recirculation (CEGR).
- **No engine regeneration is required**, so you can stay up and running.

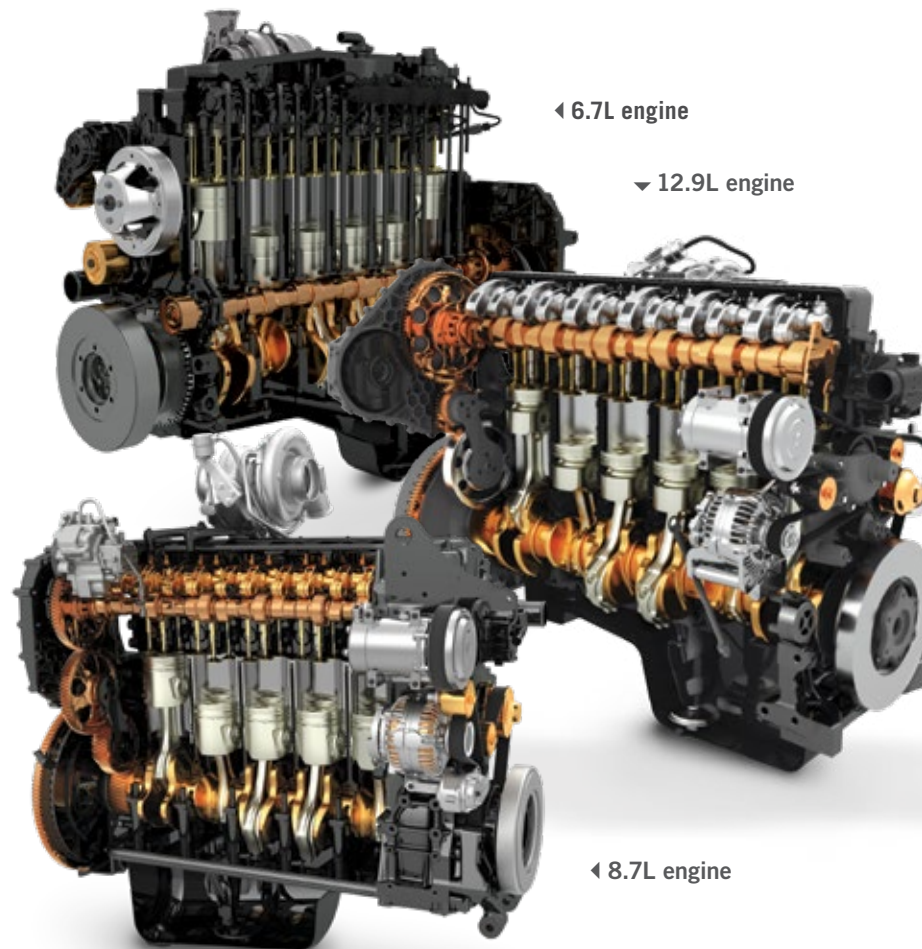

## SMART

- SCR technology provides simplified emission compliance.
- **EXCLUSIVE** Engine brake comes standard on 8.7L and 12.9L engines\*

## PROVEN

- SCR-only solution continues to perform in the field.
- Service data can be wirelessly sent to your local Case IH dealer for remote diagnostics and faster response time.





# PATENTED CASE IH EMISSIONS SOLUTIONS

Case IH FPT was the first to deliver innovative SCR-only technology. This patented technology lets Case IH achieve Tier 4 B/Final standards without adding EGR and DPF components to the powertrain system. Because Case IH FPT engines run cleaner and cooler, you reap the benefits of better fluid efficiency. In Nebraska Tractor Test Laboratory results<sup>1</sup>, that efficiency translated to 2.2% lower fluid operation costs across all wheeled Steiger tractor models compared to competitive models. Now that's High-Efficiency tractor technology that delivers results.

- Single SCR-only solution does it all with class-leading power that does not compromise efficiency.
- Patented SCR-only Tier 4 B/Final design delivers 95% NOx conversion efficiency vs. competitive systems that provide only 80% to 85% efficiency.
- Designed to optimize fuel efficiency.
- Case IH FPT SCR-only patented engines are the benchmark for engine technology in the agriculture and construction industry.

**POWERFUL. EFFICIENT. SMART. PROVEN.**

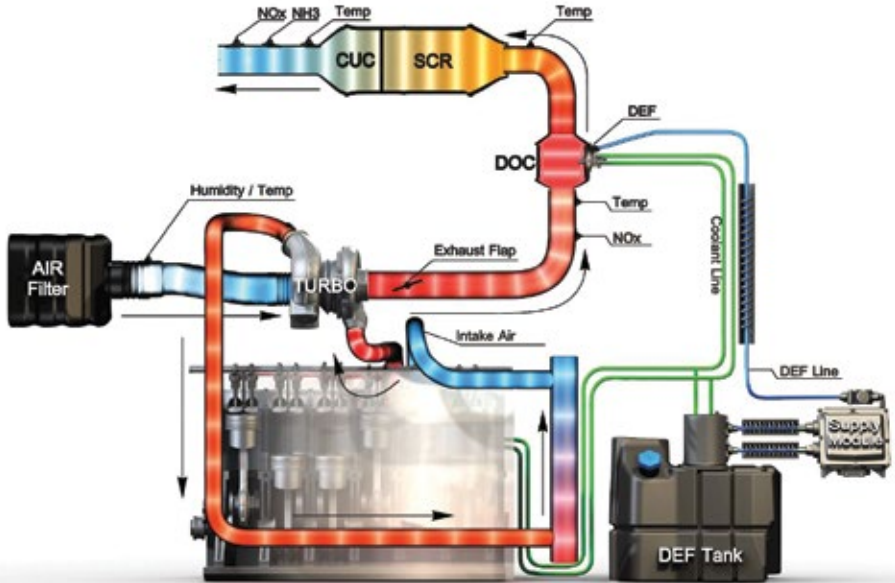

<sup>1</sup>Source: [tractortestlab.unl.edu/](http://tractortestlab.unl.edu/)

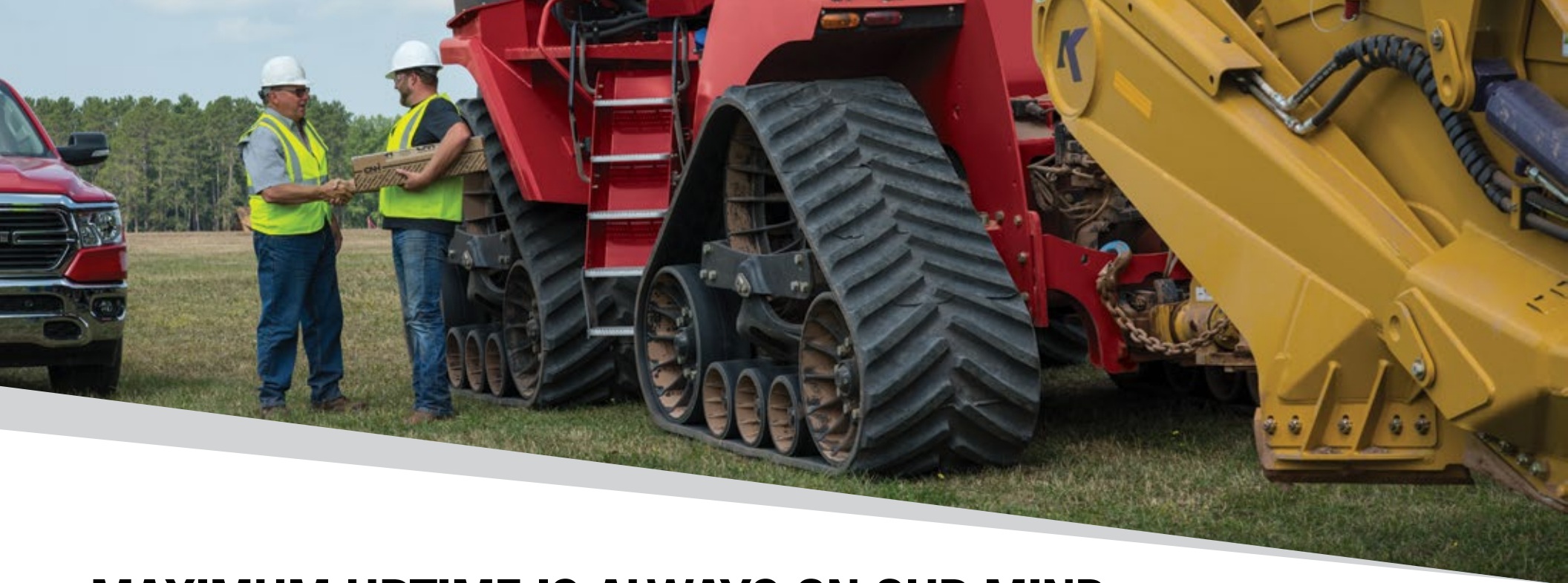

# MAXIMUM UPTIME IS ALWAYS ON OUR MIND

The job site doesn't account for downtime. For maximum productivity, you need to stay up and running. From the rugged frame construction to the heavy-duty powertrain, Case IH tractors are designed to keep you working. Case IH dealers are certified to maintain every component of your tractor, including the engines. When you buy a Case IH tractor, we want you to use it.

## QUICK AND EASY DAILY MAINTENANCE

- All transmission, hydraulic/axle and engine fluids are **serviced at ground level**.
- Exclusive 600-hour engine oil change intervals.
- **A right-hand service door and ladder** makes it easy to service components in and on the cab, clean cab glass and communicate with someone outside the right side of the tractor. The right-hand service door also provides access to the electrical cutoff switches during tractor storage.
- Does not require additional emission components such as Diesel Particulate Filter (DPF) and Cooled Exhaust Gas Recirculation (CEGR).
- **No engine regeneration is required**, so you can stay up and running.

## THE PROOF IS IN THE FINISH

Upgraded paint quality — **Class 6 automotive-grade paint provides 50% longer life and less fading**, increasing your resale value.

## FLEET-FRIENDLY FLUID OPTIONS

Thanks to fluid formulations from Case IH, equipment owners need only stock three key fluids for their fleets.

- Case IH Hy-Tran® Premium hydraulic and transmission fluid.
- Case IH No.1 Engine Oil™ SAE 10W-40 CK-4 Semi-Synthetic fluid.
- Case IH Extended Life OAT Coolant/Antifreeze fluid.



### A FUEL TANK THAT LASTS AS LONG AS THE TRACTOR

- With up to a **470-gallon fuel tank**, Steiger tractors have enough fuel capacity to operate a minimum of **15 hours on a single tank**.
- The **structural steel fuel tank** is built into the frame, adding **extra strength and durability** to the chassis.

### NEBRASKA TEST DATA\*: DRAWBAR FUEL EFFICIENCY

**“I was impressed it didn’t burn that much more fuel as we went up in speed. The [fuel] efficiency almost got better at the higher speeds.”**

– Kurt Druffel  
Pullman, Washington

### CASE IH STEIGER 620 TIER 4B VS. JOHN DEERE 9620R TIER 4B

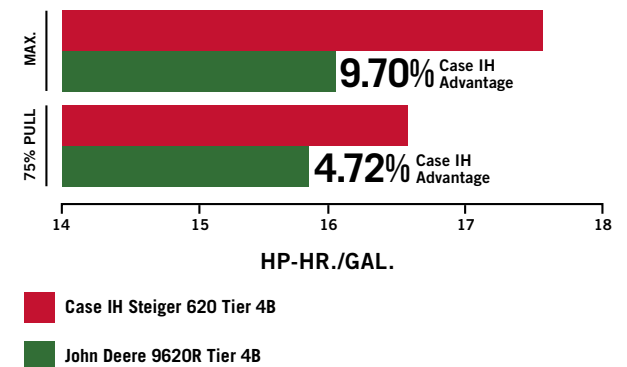

\*2.1% lower total operating cost by weighted average (\$0.0023/hp-hr.). Yearly costs assume usage of 685 hours and average of 75% power. Results from PTO dyno and drawbar tests combined (Nebraska Test 2092, September 2014 (370), Nebraska Test 2093, September/October 2014 (420), Nebraska Test 2094, September 2014 (470), Nebraska Test 2095, September/October 2014 (500), Nebraska Test 2096, September 2014 (540), Nebraska Test 2162, October 2016 (580), Nebraska Test 2164, September/October 2016 (580), Nebraska Test 2107, March/April 2015 (9370R), Nebraska Test 2108, April 2015 (9420R), Nebraska Test 2109, April 2015 (9470R), Nebraska Test 2111, April/May 2015 (9520R), Nebraska Test 2133, November 2015 (9570R), Nebraska Test 2135, November 2015 (9620R)).





# A CHOICE IN TRANSMISSIONS TO GET THE MOST FROM YOUR WORK

Equipped with a choice of two industry-leading transmissions, your Case IH tractor can perform in any application—leading to greater productivity for your fleet.

- The 19-speed PowerDrive Powershift transmission delivers smooth shifting and power transfer for maximum productivity. APM diesel saving technology and Skip Shift™ improve efficiency with faster cycle times.
- The CVXDrive Continuously Variable transmission gives you simple, no-fuss operation and precise speed without any compromise.



No matter the transmission you choose, perform transmission calibration from inside the cab to improve shifting performance.

Steiger Product Lineup							
STEIGER MODEL	370	420	470	500*	540*	580*	620*
Peak Engine Power	425	462	517	550	605	638	692
PowerDrive Transmission 	●	●	●	●	●	●	●
CVXDrive Transmission 	○	○	○	○	○	NA	NA

● Standard Transmission ○ Optional Transmission



**Magnum Product Lineup**

MAGNUM MODEL	180	200	220	240	250	280	310	340	380	400
Peak Engine Power	200	220	240	260	285	315	345	375	415	435
PowerDrive Transmission 	●	●	●	NA	●	●	●	●	NA	●
CVXDrive Transmission 	○	○	○	●	○	○	○	○	●	NA



# STEIGER POWERDRIVE TRANSMISSION

TRACTOR MODEL	HP	FPT ENGINE	AXLE	HYDRAULICS
Steiger 370 Wheeled	370	8.7 L	Heavy-duty planetary bar axles on wheeled models; flanged axle on Quadtrac models. Internal wet brakes on front and rear axles. Standard independent Auto Differential Locks provide maximum traction at all times with little to no operator effort. It works automatically, allowing you to focus on the task at hand.	Four remotes standard with up to eight optional remotes available. 57 gpm standard flow with up to 113 gpm optional. Standard laser/GPS interface.
Steiger 420 Wheeled	420	12.9 L		
Steiger 470 Wheeled	470			
Steiger 500 Wheeled & Quadtrac	500*			
Steiger 540 Wheeled & Quadtrac	540*			
Steiger 580 Wheeled & Quadtrac	580*			
Steiger 620 Wheeled	620*			





# MAGNUM POWERDRIVE TRANSMISSION

TRACTOR MODEL	HP	FPT ENGINE	AXLE	HYDRAULICS
Magnum 180 Wheeled	180	6.7L	Bar axle with internal wet disk brakes and hydraulically activated differential lock. Suspended front axle recommended. Independent auto differential locks provide maximum traction at all times with little to no operator effort. It works automatically, allowing you to focus on the task at hand.	Three remotes standard with up to five optional remotes available. 41 gpm standard flow on PowerDrive models.
Magnum 200 Wheeled	200			
Magnum 220 Wheeled	220			
Magnum 250 Wheeled	250	8.7L		Five remotes standard with up to six optional remotes available. 59 gpm standard flow with up to 83 gpm optional. Standard laser/GPS interface.
Magnum 280 Wheeled	280			
Magnum 310 Wheeled	310			
Magnum 340 Wheeled	340			
Magnum 400 Wheeled	396			





## CVXDRIVE: GIVING YOU MORE CONTROL OVER THE MOST EFFICIENT POWER AVAILABLE

CVXDrive represents the highest-horsepower continuously variable transmission in the industry — 613 peak horsepower on Steiger 540 HP models. The **CVXDrive operates like an automatic transmission** and provides all-new opportunities for your business. **Once the speed is set, the operator is free to focus on the application for improved performance.** And CVXDrive provides **steady speed change to maintain full power to the ground** at speeds as low as 3 feet per minute thanks to the efficient, four-range design. Even the toughest jobs don't stand a chance.



# STEIGER CVXDRIVE TRANSMISSION

TRACTOR MODEL	HP	FPT ENGINE	AXLE	HYDRAULICS
Steiger 370 Wheeled	370	8.7L	Heavy-duty planetary bar axles on wheeled models; flanged axle on Quadtrac models. Internal wet brakes on front and rear axles. Standard independent auto differential locks provide maximum traction at all times with little to no operator effort. It works automatically, allowing you to focus on the task at hand.	Four remotes standard with up to eight optional remotes available. 57 gpm standard flow with up to 113 gpm optional. Standard laser/GPS interface.
Steiger 420 Wheeled	420	12.9L		
Steiger 470 Wheeled & Quadtrac®	470			
Steiger 500 Wheeled & Quadtrac	500			
Steiger 540 Wheeled & Quadtrac	540			



# MAGNUM CVXDRIVE TRANSMISSION

TRACTOR MODEL	HP	FPT ENGINE	AXLE	HYDRAULICS
Magnum 180 Wheeled	180	6.7L	Bar axle with internal wet disk brakes and hydraulically activated differential lock. Suspended front axle recommended. Independent auto differential locks provide maximum traction at all times with little to no operator effort. It works automatically, allowing you to focus on the task at hand.	Four remotes standard with up to five optional remotes available. 43 gpm standard flow on CVXDrive models.
Magnum 200 Wheeled	200			
Magnum 220 Wheeled	220			
Magnum 240 Wheeled	240			
Magnum 250 Wheeled	250	8.7L	Bar axle with internal wet disk brakes and hydraulically activated differential lock. Suspended front axle recommended. Independent auto differential locks provide maximum traction at all times with little to no operator effort. It works automatically, allowing you to focus on the task at hand.	Four remotes standard with up to six optional remotes available. 59 gpm standard flow with up to 83 gpm optional. Standard laser/GPS interface.
Magnum 280 Wheeled	280			
Magnum 310 Wheeled	310			
Magnum 340 Wheeled	340			
Magnum 380 Wheeled	380			

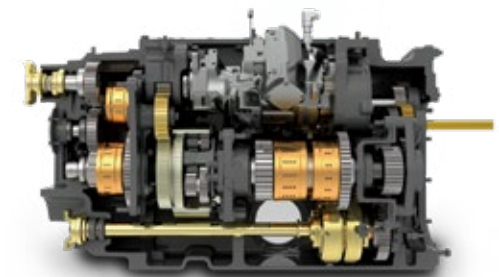



# BUILT TO WORK IN THE DIRT

## THE RIGHT HORSEPOWER FOR YOUR FLEET

The Steiger 620 delivers 10% power growth for 692 peak HP to handle the largest scrapers and heaviest loads. It has a two-stage turbocharger system: a small turbocharger provides responsiveness and a second, larger turbocharger offers maximum boost at high rpm. That means the Steiger 620 has the ability to pull up to three 18-yard scraper pans or one 26-yard scraper pan.

## TRI-POINT OSCILLATION

Tri-point Oscillation is engineered into every Steiger tractor to **provide the perfect mix of strength and balance when transferring power to the ground.** The steering cylinders are mounted low, and in direct line to the torsional stresses placed on the tractor. The large top link extends from the front frame to the rear frame to transfer dynamic loads efficiently.

Each individual track oscillates **10 degrees up and down to follow the ground contour** and provide more power in different terrain applications.

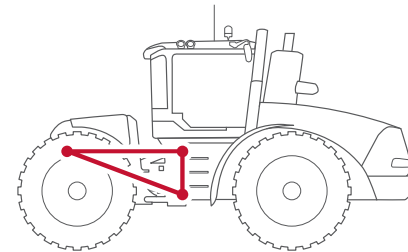

Tri-point Oscillation provides rigidity and strength for heaviest application.\*

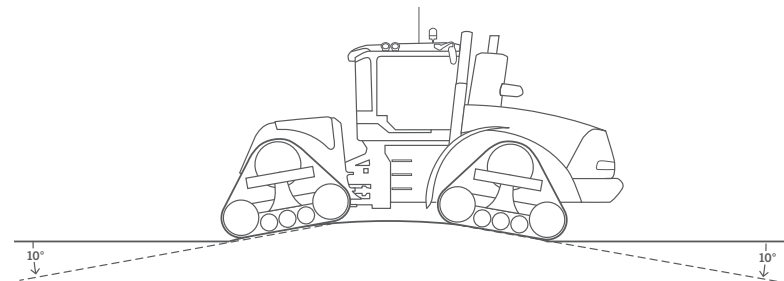

Total soil contact at all times.\*





# REDEFINING RUGGED POWER

## STEIGER STRONG

The longer wheelbase and built-in weight of a heavy frame on Steiger 470 tractors provide more power to the ground plus the heft and durability needed for earthmoving. The wide frame of 500, 540, 580 and 620 wheeled models set new productivity benchmarks for the industry. Features like **heavy-duty drivetrain components**, available **113-gallon-per-minute hydraulic flow** and **power growth up to 682 peak HP** have raised the bar as well.

## MORE POWER, MORE DURABILITY, MORE PROFIT

Steiger scraper tractors come with four standard hydraulic remotes with the option to add four more. **A quick-attach heavy-duty scraper drawbar is designed specifically for scraper demands.**

Steiger scraper tractors also feature all-new vertically aligned hydraulic valve couplers designed for **greater ease of attaching and detaching and improved hydraulic flow.**

## BUILT SPECIFICALLY FOR LAND SHAPING

**Case IH scraper tractors come standard with many features that have big benefits for earthmoving and land leveling.**

- All commercial Steiger scraper tractors have a larger 620 HP transmission
- Seat swivels 40 degrees to the right for unmatched visibility of your attachment
- Automatic differential locks
- 4-point fully suspended cab
- Backup alarm
- Tow cable
- 20,000-lb. scraper drawbar
- Antivandalism lockdown package
- Specifically designed with standard roll over protection/falling object protection structure (ROPS/FOPS) certified to 66,000 lb.

## CAB SUSPENSION FOR A SMOOTHER RIDE

Case IH **cab suspension systems stabilize cab motion** to give you a smooth ride — regardless of terrain. **Standard on all Steiger and Magnum wheeled, Quadtrac and Rowtrac™ models**, the system reduces jarring and bouncing to give you greater focus on the job and more control over your tractor. In addition, Steiger Commercial scraper tractor models come **standard with falling object protection (FOPS) and roll-over protection (ROPS)**.

## CRUISE THROUGH LONG DAYS IN THE INDUSTRY'S FIRST SUSPENDED CAB

- Exclusive **4-point cab suspension** stabilizes front-to-back, side-to-side and up-and-down motions.
- Enjoy a smooth ride regardless of terrain with **shock-absorbing components** at each corner of the cab.
- A combination of springs, dampers and mounts fully isolate the cab from chassis-created vibrations.
- The **fully suspended four-post cab suspension system** eliminates repeated jarring and bouncing.

## FOUR-POST CAB SUSPENSION

**A** Torsion Bar

**B** Panhard Rods

**C** Longitudinal Rods

**D** Substructure

**E** 4 Springs

**F** 4 Dampers

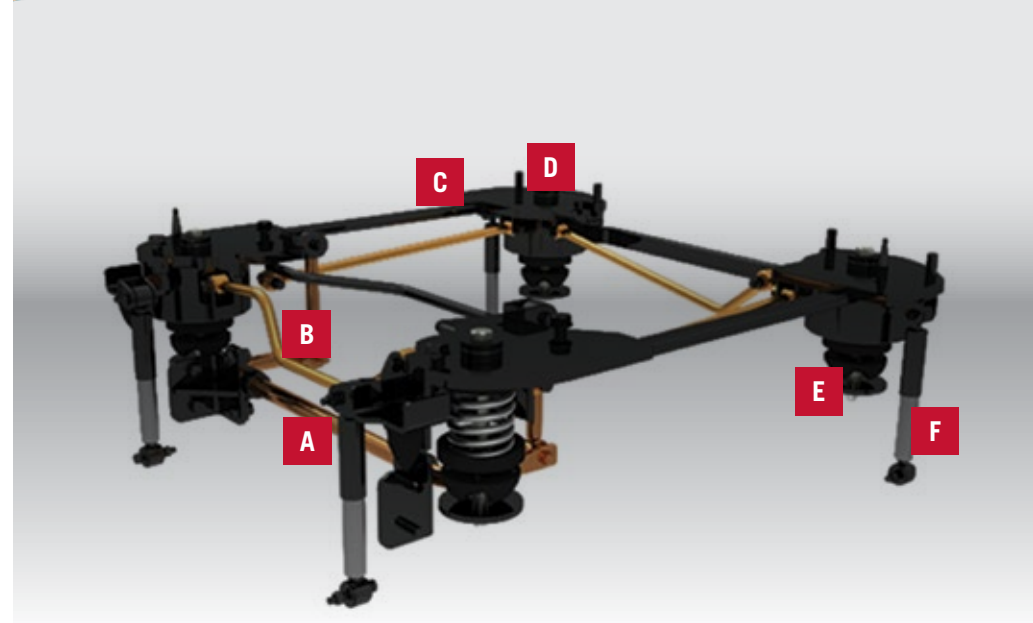



# LEGENDARY 4-TRACK DESIGN



Thanks to the size of its footprint and its five-axle design, the Steiger Quadtrac tractor's footprint allows an earlier start on the job than competitive track designs, as **proven in millions of hours of actual field use in commercial and agricultural applications.**

## CASE IH TRACK LEADERSHIP

Four individually driven tracks, each with three idler wheels, create more ground contact area for better flotation, traction and easier transport. **The design distributes loads evenly across the length of each track – even under load.**

In addition, all Steiger Quadtrac scraper tractors come equipped with a self-tensioning track system, which maintains the correct belt tension at all times for a longer track life.

## FULL POWER IN TURNS

Quadtrac tractors **keep full power in turns under load.** No additional power is required to turn. The articulated steering of a Steiger Quadtrac operates like a typical 4WD wheeled tractor, **preventing ridging and berming.**

## EASY MAINTENANCE TRACKS

Today's Case IH Steiger Quadtrac tractors also have an **undercarriage that is maintenance-free with clear caps and sight gauges.**



# MAGNUM POWER EXCELS ON YOUR JOB SITE

Thanks to class-leading power, Case IH Magnum series tractors offer unmatched performance in tough pulls. **You can count on increased productivity in your land leveling and scraper operations.** With up to 14% power growth, the powertrain of a Magnum tractor is designed to efficiently pull scrapers at speeds above 4 mph.

## **UNLIMITED POSSIBILITIES, MAXIMUM VERSATILITY: MAGNUM 180–240 TRACTORS**

Get the maximum benefit from your Magnum 180 to 220 tractor with the standard 19-speed PowerDrive powershift transmission (Magnum 240 CVXDrive only). Magnum 180 to 240 tractors **can be configured for use with front duals and are a perfect match for smaller scrapers.**

## **POWER FOR MORE LOADS IN A DAY: MAGNUM 250–400 TRACTORS**

Magnum 250 to 400 tractors have the power to take on the toughest tasks. Handle hard-pulling applications with 250 to 400 engine HP, and up to 14% power growth. **More built-in ballast improves traction, improves your tractive effort to fill the largest scrapers and places your tractor's horsepower to the ground.**

## **SMOOTH POWER TO THE GROUND – MAGNUM CVXDRIVE OPTION**

Experience the proven performance of the Case IH CVXDrive that performs like an automatic transmission. The CVXDrive uses Case IH current technology to deliver uninterrupted power to the ground. A four-range design efficiently delivers more power for tough jobs. The Case IH CVXDrive **automatically adjusts to match ground speed to any job-site conditions.**





# WORK SMARTER AND IN COMFORT, IN ANY CONDITIONS

Comfort is a priority when you spend long days on the job site, and Case IH delivers, thanks to input from our customers. **The Steiger Surveyor® cab offers unmatched comfort and visibility.** The cab is quiet, so you can talk on your phone or multitask as needed to run your business. **Full cab suspension comes standard on all Steiger and Quadtrac tractors.**

## RELIABLE PERFORMANCE, DAY IN AND DAY OUT

When you're on the job, uptime is the bottom line. You have to keep moving and so does your equipment. **Rugged frames, durable drivetrains and powerful, fuel-efficient engines** are the keys to durability and productivity.

## HARD WORK SHOULDN'T BE A PAIN IN THE NECK

Autoguidance systems give you more freedom in the cab to look back and check on implement operations. So your tractor's seat shouldn't force you to keep looking

forward. The Case IH industry-leading **40-degree, right-hand swivel seat** in Steiger tractors gives you an exclusive **360-degree full field of vision** that keeps you from having to strain your neck. The cab, radio and HVAC controls are on the upper right or can be put on armrest buttons, so everything is within reach.

## HELPING YOU KEEP THINGS UNDER CONTROL

Case IH tractors feature the Case IH Diesel-Saver Automatic Productivity Management™ (APM) system to help you maintain speed and precise control through the cut. APM automatically upshifts or downshifts as the load, grade or soil condition changes, **ensuring peak speed and fuel efficiency.** All Steiger 420–620 and Magnum 250–380 tractors have an engine brake that provides added control of your load on slopes.



- A** Luxury Leather, Heated/Ventilated Seat with 40-degree Swivel
- B** Luxury Leather Instructor Seat
- C** Molded Floor Mat
- D** Motorcycle-style Foot Pegs
- E** Wider, Larger Windshield Wipers
- F** Telescoping Steering Wheel with Memory Lock

- G** Instrument Cluster with Key Machine Information
- H** AFS Pro 1200 Display
- I** Ergonomic MultiFunction Handle Controls 95% of Tractor and Machine Operations
- J** Color-coded, Configurable, Electro-hydraulic Remotes (EHR)
- K** Encoder Knob enables quick adjustments of multiple settings from air conditioning to radio.
- L** Leather MultiControl Armrest

Not Shown:

RAM Device Mounts

USB Ports for System Data and 3 Pin Power Ports for 12V accessories

Storage/Cup Holders

Exclusive Front and Rear Independent, Automatic Differential Locks

**MAGNUM CVXDRIVE  
CAB SHOWN**



**A** Luxury Leather, Heated/Ventilated Seat with 40-degree Swivel

**B** Storage/Cup Holders

**C** Luxury Leather Instructor Seat

**D** Full Glass Door with No Center Pillar with Optional Wiper and Sun Shade

**E** Molded Floor Mat

**F** Motorcycle-style Foot Pegs

**G** Zone Controlled HVAC Airflow

**H** Telescoping Steering Wheel with Memory Lock

**I** Forward/Reverse Speed Control (CVXDrive) Throttle Control (PowerDrive)

**J** Redesigned, Ergonomic, Multifunction Handle

**K** Instrument Cluster with Key Machine Information

**L** AFS Pro 1200 and LCD with Anti-glare Screens

**M** Color-coded Electro-hydraulic Remotes

**N** Encoder Knob

**O** Multicontrol Armrest

**P** Ram Device Mounts

**Q** USB, 3 Pin/12-Volt Power and Data Ports Throughout the Cab

**R** 3-Point Hitch Control

# AN OPERATOR ENVIRONMENT ABOVE THE REST

When we designed our Magnum and Steiger cabs, our engineers started with a clean slate. We used **years of research and input from our most qualified expert: you.** The result is an interior that blends simplicity and luxury like you've never experienced in a tractor cab before.

- A** Shortcut keys provide one touch access to commonly used functions
- B** Exclusive front and rear independent, automatic differential locks
- C** Ninth programmable hot key button provides more shortcut options
- D** Configurable hot keys 1–4
- E** Configurable hot keys 5–8
- F** Configurable, color-coded electro-hydraulic remote (EHR) levers
- G** 12-in. AFS Pro 1200 display is just like using a smartphone or tablet

## **H** MULTIFUNCTION HANDLE

Redesigned and ergonomic multifunction handle puts 95% of the commonly used controls at your fingertips.

## **I** EXCLUSIVE SPLIT THROTTLE

Available with CVXDrive transmission and allows the operator to **set upper and lower engine RPMs to keep you in total control.**

## **J** MULTICONTROL ARMREST

Proven design now features an encoder for **complete control at your fingertips.**



# AFS CONNECT STEIGER QUADTRAC

Case IH industry-leading Quadtrac technology features four individually driven, positive drive, oscillating tracks. Each track maintains constant contact with the ground for a smooth ride, optimal ground pressure, superior flotation and better traction.



## D CVXDRIVE TRANSMISSION

Steiger was the **first articulated high-horsepower four-wheel-drive tractor with a continuously variable transmission**. Available in 17 configurations with up to 613 peak horsepower.

## E LED GRILLE-MOUNTED WORK LIGHTS

Operate whenever you need to with lights that provide **superior visibility at night**.

## EXCLUSIVE DUAL COOLING SYSTEMS

The Steiger 540, 580 and 620 tractors feature a **low-pressure cooling circuit system that provides increased power along with fuel efficiency**. The two-stage turbocharger system includes a small turbocharger that delivers low-RPM responsiveness and a second, larger turbocharger for maximum boost at high RPMs. Each turbocharger has its own load cooling system to provide 40% faster response under load.

## A AFS VECTOR PRO RECEIVER

Consolidated components **improve guidance consistency and line acquisition**.

## B INTUITIVE CVXDRIVE CONTROLS

**Exclusive split throttle design** for CVXDrive models is **easy to use**. Set your engine RPM and the CVXDrive transmission allows the engine to work throughout the entire range to achieve the perfect balance of power and efficiency.

## C TRI-STRIPE DECAL

Updated styling reflects the latest design seen only on new Case IH tractors and reminds us of three key points found in every AFS Connect Steiger: **easy-to-use technology, ultimate comfort with ergonomic control and superior power to the ground**.



## F BOLT ON WHEELS

Polyurethane bonded rollers bolt to the new axle hubs. **This reduces the time required for service and improves uptime**.

**G POWER ADJUSTABLE MIRRORS**

Electronic telescoping mirrors are controlled from the tractor cab for effortless adjustments.



**H LED LIGHTS**

New customizable LED lights provide enhanced front and side visibility, allowing you the freedom to customize which lights should be on or off as needed for your operation.

**I 360-DEGREE EGRESS LIGHTING**

Located at every angle around the tractor to give you better visibility upon exiting the cab in low-light situations.

**REMOTE EQUIPMENT MONITORING**

Access equipment information, as well as set equipment parameters, remotely on your mobile device.

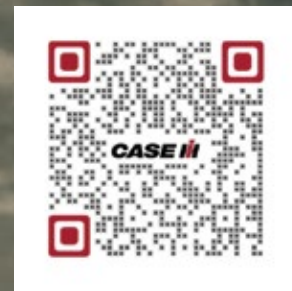

Scan to learn more about Steiger Series Tractors

**M STANDARD 4-POINT CAB SUSPENSION**

Stabilizes front-to-back, side-to-side and up-and-down motions creating a smooth ride regardless of terrain.

**J TRI-POINT OSCILLATION**

This standard feature on all AFS Connect Steiger tractors transfers more weight to the front, which provides 50/50 weight splits under load and provides improved performance pull.

**K CAST UNDERCARRIAGE SYSTEM**

Heavy-duty cast undercarriage designed by Case IH engineers for the rugged frame of Steiger tractors for enhanced durability and reliability.

**L EXCLUSIVE TRACK TECHNOLOGY**

Self-tensioning tracks eliminates the need for tools and keeps you up and running.



# AFS CONNECT STEIGER WHEELED

4WD force makes Steiger wheeled tractors ideal for tackling serious earthmoving. Plus, get more traction and less compaction with a longer wheelbase and the tallest factory-fit tires in the industry.

## A POWERDRIVE POWERSHIFT TECHNOLOGY

The time-tested and fluid-efficient PowerDrive powershift does more than just shift gears. With the latest Steiger enhancements, **it takes 20% less time to shift from first gear to 16th gear, saving you fuel, lowering operating costs and reducing fatigue.** And during shuttle operation, a producer can change direction 38% faster than before.

## B PROVEN ENGINES

The Case IH FPT engine has passed every challenge and is built with efficiency in mind. Case IH FPT 8.7L and 12.9L engines incorporate patented fluid-saving SCR-only technology that produces more power using less fuel. **And, with 600 hour oil-change intervals, achieve greater fluid efficiency and lower operating costs.**

## C CONFIGURABLE HYDRAULICS

AFS Connect Steiger tractors **provide up to 113 gpm hydraulic flow, allowing you to run at lower engine rpm in order to conserve fuel** without affecting operational performance. Up to eight remote valves are available.

## D PATENTED SCR SYSTEM

Eliminates the need for engine regeneration and provides increased fuel efficiency.

## E NEW FRONT CAB ROOF MOUNTED LED LIGHTS

New customizable LED lights provide **enhanced front and side visibility** giving you the ability to program them to meet your specific needs.

## F EXCLUSIVE SKIP SHIFT™ TECHNOLOGY

Faster cycle times and the ability to **quickly shift from low to high gears** for more efficient roading and loading.

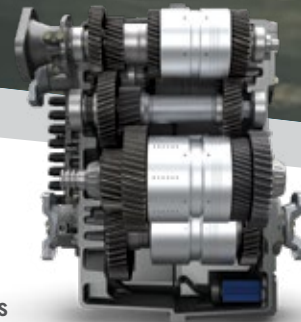

<sup>1</sup> Steiger 620 Tier 4B (Nebraska Test 2164, September/October 2016): maximum drawbar fuel efficiency at 17.63 hp-hr./gal. at rated engine RPM, and at 75% pull at rated engine RPM 16.61 hp-hr./gal.; compared with John Deere 9620R Tier 4B (Nebraska Test 2135, November 2015): maximum drawbar fuel efficiency at 16.07 hp-hr./gal. at rated engine RPM and at 75% pull 15.86 hp-hr./gal. Steiger 620 Tier 4B (Nebraska Test 2164, September/October 2016): maximum observed drawbar horsepower of 594.08 hp; compared with John Deere 9620R Tier 4B (Nebraska Test 2135, November 2015): maximum observed drawbar horsepower of 556.83 hp. Steiger 620 Tier 4B (Nebraska Test 2164, September/October 2016): maximum pull at 65,077 lb., compared with John Deere 9620R Tier 4B (Nebraska Test 2135, November 2015): maximum pull at 60,455 lb.



## **G** STANDARD ADVANCED STEERING SYSTEM

The Case IH Advanced Steering system that **gives an operator smoother and more precise control of the tractor and implement** at every speed now **comes standard on every Steiger tractor**. Transitioning between loading and unloading cycles is easier. And unlike previous systems that required four full rotations of the wheel to go lock-to-lock, this system only requires 3 1/2 turns. The steering now has **three modes of adjustment—slow, medium and fast—** so you can tailor the steering to your applications.



Scan to learn more about Steiger Series Tractors

## **H** STRUCTURAL STEEL FUEL TANK

Every AFS Connect Steiger fuel tank is made of durable structural steel, unlike competitive offerings. This important design difference **adds additional weight and strength to the Steiger chassis**.

## **I** STANDARD HEAVY-DUTY AXLES

All AFS Connect Steiger tractors feature massive heavy-duty axles that can **carry up to 66,000 lb. of gross vehicle operating weight**. These enormous axles are **5.5 in. in diameter with 18-bolt hubs and also feature unparalleled braking and hydraulic pressure** for feel and modulation. It all adds up to greater strength and durability. All new AFS Connect Steiger **500 and 540 models feature new heavier 5 in. bar axles** on both ag and scraper versions.

**H**

**C**

**I**

**J**

## **J** MOST POWERFUL WHEELS ON THE MARKET

It's one thing to produce a lot of horsepower. The **Nebraska Tractor Test Laboratory proved** the Steiger 620<sup>1</sup> wheeled tractor does that better than any other, and the Steiger 580<sup>2</sup> set the second-highest drawbar fuel economy ever recorded.\* But what really matters, and where the Steiger lineup excels, is moving this industry-leading power efficiently throughout the tractor and, ultimately, to the ground and implement being pulled. **Superior tractive capabilities using automatic differential locks reduce slippage in difficult field conditions.**

## **REMOTE EQUIPMENT MONITORING**

Access equipment information, as well as set equipment parameters, remotely on your mobile device.

<sup>1</sup> Steiger 620 Tier 4B (Nebraska Test 2162, October 2016): maximum drawbar fuel efficiency at 17.53 hp-hr./gal. and 75% of pull maximum power at 16.44 hp-hr./gal.; compared with John Deere 9570R (Nebraska Test, 2133 November 2015): maximum drawbar fuel efficiency at 15.71 hp-hr./gal. and 75% of pull maximum power at 15.42 hp-hr./gal. <sup>2</sup> Steiger 580 Tier 4B (Nebraska Test 2162, October 2016): drawbar horsepower at 495.25 hp; compared with John Deere 9570R (Nebraska Test, 2133 November 2015): drawbar horsepower at 450.82 hp.

# AFS CONNECT MAGNUM WHEELED

The AFS Connect Magnum series tractor has evolved styling and features to deliver exactly what you need to make your job easier and more productive.

## REDESIGNED FOR YOUR PRODUCTIVITY



### F STANDARD ADVANCED STEERING SYSTEM

The Case IH Advanced Steering system that gives an operator **smoother and more precise control** of the tractor and implement at every speed now comes standard on every Magnum tractor.

### E PATENTED SCR SYSTEM

Eliminates the need for engine regeneration.

### D TRI-STRIPE DECALS

**Updated styling** reflects the latest design seen on new Case IH tractors.

### A CAMERAS

The AFS Pro 1200 display has **four camera inputs**. Front and rear cameras are included with the luxury cab package. Connections for four cameras are standard.

### B LED LIGHTS ON HOOD AND CAB TOP

Operate whenever you need to with lights that provide **superior visibility at night**.

### C PROVEN ENGINES

The Case IH FPT engine has passed every challenge and is built with efficiency in mind, Case IH FPT 6.7L and 8.7L engines incorporate patented SCR-only technology for greater productivity that produce more power. And, with **600 hour oil-change intervals**, achieve **greater fluid efficiency and lower operating costs**.

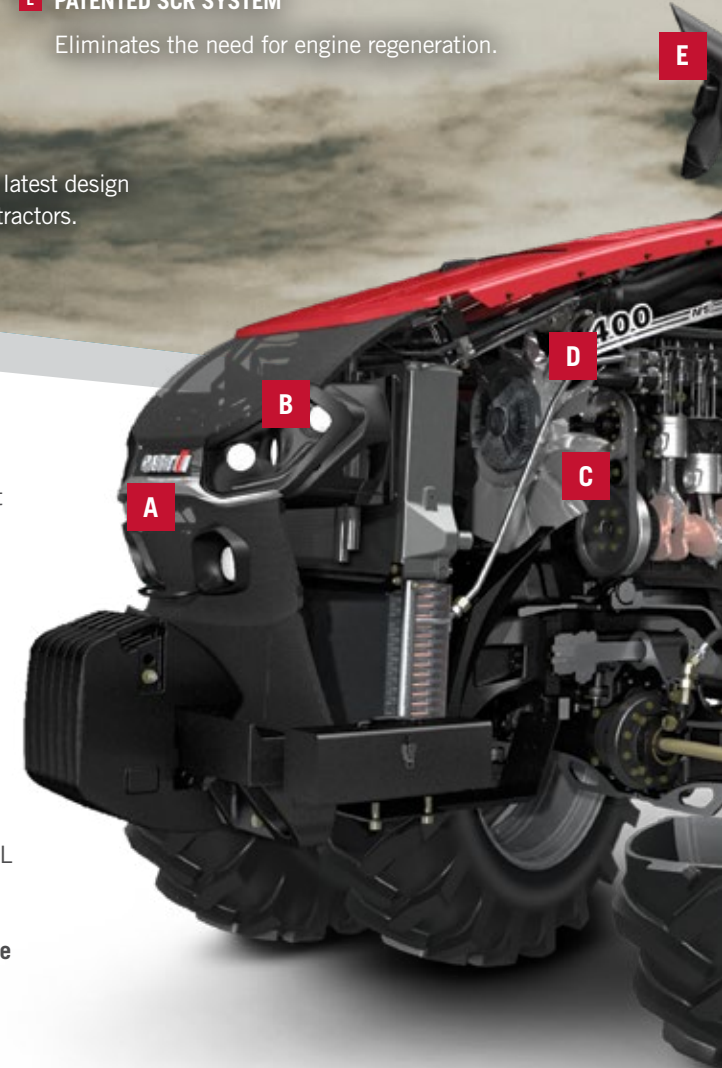

**G AFS VECTOR PRO RECEIVER**

Consolidated components **improve guidance consistency.**

**H MIRRORS**

Telescoping and heating (luxury cab) **mirrors are controlled from inside the tractor cab** for easy adjustments.

**I BREAKAWAY-STYLE MARKER LIGHTS**

Up your visibility with marker lights **designed to break away** if they encounter an obstacle but won't break off.

**J 360-DEGREE EGRESS LIGHTING**

Located at every angle around the tractor to give you **better visibility upon exiting the cab in low light situations.**

**K SEMI-ACTIVE CAB SUSPENSION**

Improved cab comfort reduces operator fatigue for a **smooth ride on long days in the field.**

**L CAST WHEEL SPACERS**

Machining minimizes tire runout and **improves hub retention.**

**M TIRE PRESSURE MONITORING SENSORS**

Monitor and view tire pressure through the AFS Pro 1200 display.



Scan to learn more about  
Magnum Series Tractors



# PRODUCTIVITY, CONNECTIVITY AND PROFITABILITY

AFS Connect provides an end-to-end solutions to remotely monitor and manage your fleet. Optimize your performance, productivity and flexibility. Visualize your equipment data to help you make better, more informed for your operation. Plus, with the AFS Connect app on your phone or tablet, you can successfully manage your fleet and operations anytime, anywhere.

**AFS Connect Steigers and Magnums are factory equipped with a subscription to AFS Connect.**



## THE AFS PRO 1200 DISPLAY

The AFS Pro 1200 features a crystal-clear, anti-glare, LCD, 12-in. touchscreen display that provides critical information in an **easy-to-understand format**. With just a few touches, you can view and fine-tune operator preferences, calibrate the tractor settings, as well as other key machine functions, **all while monitoring crucial job site data and boundaries**.

## FLEET MONITORING FOR OPTIMIZED PERFORMANCE

Monitor equipment and logistics to achieve peak performance. This includes **machine status, engine hours, idle time, operational time and fuel/DEF levels**. Maximize uptime by **configuring notifications on your phone or mobile devices** so you know exactly when parameters like speed, temperatures or fluid levels are less than, equal to or greater than limits you specify.

## BETTER TRACKING FOR GREATER EFFICIENCY

When it comes to running an efficient operation, **knowing when, how and where your equipment is being used is key to greater productivity**. And while keeping track of all of your equipment might have been a hassle in the past, new 24-hour vehicle history tracking, Geofence Boundaries and Curfew rules from AFS Connect make vehicle monitoring easy.

## FULL REMOTE VISIBILITY

**No matter where an operator is located, see exactly what they're seeing on the screen in the tractor cab**. Plus, you can work with your local Case IH dealer to **remotely diagnose maintenance and service issues** and identify the parts you need to stay up and running.



## EQUIPMENT INFORMATION AT YOUR FINGERTIPS

When you have questions about Case IH equipment maintenance, there's no time to lose to get back on the job. MyCaseIH.com is your all-new destination for **Case IH product support, including free operators manual downloads, AFS training videos, how-to tutorials and maintenance tips** to provide the information you need.

Create a free MyCaseIH account and use the same login credentials to access the features of AFS Connect and the AFS Connect app today!



## THE AFS CONNECT APP

- Use the **AFS Connect app** to monitor and manage your fleet in one place, all on your mobile device or tablet. Gain insights into equipment status, receive pertinent notifications and more to help keep your business working efficiently.





# SERVICEABILITY AND SUPPORT

Whether you are three miles or 300 miles away, get the support you need from your knowledgeable Case IH dealer. **New features on the AFS Connect Steiger tractor allow dealers to better support you and your fleet remotely — and in real time.** That means no more waiting for a service truck to drive to the farm to diagnose an issue or driving around looking for the right part. When you need service, dealer technicians are ready to help you eliminate unnecessary downtime.

- Ground-level access to engine, transmission, hydraulic and axle fluids makes maintenance easy.
- Quadtrac tractors are designed with a maintenance-free undercarriage with clear caps, self-tensioning track, no-grease zerks and debris ejection in mind.
- Industry-leading 600-hour oil change Intervals help keep you in the field longer.
- Extended service life brakes absorb more heat, so they last longer and in more extreme conditions.
- Case IH Dealers and Technicians are ready to handle any service issues to keep you going.

## KNOWLEDGEABLE DEALERS WHO WORK WITH YOU

Case IH dealers understand the need to optimize your equipment return on investment. Your dealer will work with you to configure an AFS Connect Steiger to fit your operation and provide the support you need to maximize its value. Go to [caseih.com](http://caseih.com) to build and price the tractor that fits your fleet.

STEIGER MODEL	470 WHEELED	500 WHEELED / QUADTRAC*	540 WHEELED / QUADTRAC*	580 WHEELED / QUADTRAC*	620 WHEELED*
<b>POWER</b>					
Engine Type	Tier 4 B/Final with Selective Catalytic Reduction (SCR)				
Engine HP at Rated RPM (per SAE)	470 hp @ 2,000 RPM	500 hp @ 2,100 RPM	535 hp @ 2,100 RPM	580 hp @ 2,100 RPM	620 hp @ 2,100 RPM
Peak Engine HP at 1900 RPM	517 hp @ 1,800 RPM	550 hp @ 1,900 RPM	605 hp @ 1,900 RPM	638 hp @ 1,900 RPM	682 hp @ 1,900 RPM
Cylinders / Number of Valves / Displacement	6 cyl. / 24 valves / 12.9L (787 cu. in.)				
Engine Aspiration	Wastegate turbocharger with air-to-air aftercooling		Two-stage turbocharging with air-to-water intercooling and air-to-water aftercooling		
<b>ELECTRICAL</b>					
Alternator / Battery	200 amp / 2 12-volt batteries			240 amp / 2 12-volt batteries	
<b>TRANSMISSION/PTO</b>					
Transmission – Standard / Optional	Full PowerDrive powershift 16F/2R w/16 Hi [25 mph (40 kph)] / CVXDrive™ CVT [25 mph (40 kph)]			Full PowerDrive powershift 16F/2R w/16 Hi [25 mph (40 kph)] / N/A	
PTO – Optional	1,000 RPM – 1 3/4 in shaft				
<b>AXLES</b>					
Axle Diameter – Wheeled / Quadtrac	5 in. (127 mm) planetary	4.5 in. (114 mm) compound planetary / flanged		5.5 in. (140 mm) compound planetary / flanged	
Axle Width – Wheeled / Quadtrac	120 in. (3 048 mm) / NA	120 in. (3 048 mm) / 88 in. (2 235 mm)			
Wheelbase	148 in. (3 759 mm)	154 in. (3 912 mm)			
Automatic Differential Lock	Standard				
<b>HYDRAULICS</b>					
Remote Valves – Standard / Optional	4 / Up to 8				
High Flow Hydraulic Pump (PFC)	57 gpm (216 L/min.)				
Total Tractor Hydraulic Flow with Parallel/Twin Flow Pumps	113 gpm (428 L/min.)				
Available Flow at Single Remote Valve	35 gpm (132 L/min.)				
<b>CAPACITIES</b>					
Fuel Tank – Wheeled / Quadtrac	310 gal. (1 170 L)			455 gal. (1 722 L) / 470 gal. (1 779 L)	
Diesel Exhaust Fluid (DEF) Tank	42 gal. (174 L)	66 gal. (250 L)			
Vertical Tongue	20,000 lb. (9 072 kg)				
<b>CAB</b>					
Volume (Size)	132 cu. ft. (3.7 cu. m)				
Glass	88.1 sq. ft. (8.18 sq. m)				
<b>WEIGHT</b>					
Wheeled Models – Base Shipping Weight	39,820 lb. (18 062 kg)	44,290 lb. (20 090 kg)	46,340 lb. (21 012 kg)	50,328 lb. (22 828 kg)	
Wheeled Models – Max. Gross Vehicle Weight	49,500 lb. (22 453 kg)	56,000 lb. (25 401 kg)	56,000 lb. (22 401 kg)	66,000 lb. (29 937 kg)	
Quadtrac Models – Base Shipping Weight	51,263 lb. (23 416 kg)	51,623 lb. (23 416 kg)	52,621 lb. (23 868 kg)	53,503 lb. (24 629 kg)	
Quadtrac Models – Max. Gross Vehicle Weight	64,000 lb. (29 630 kg)	64,000 lb. (29 030 kg)			

\*Designated for commercial use only

STEIGER MODEL	370 WHEELED	420 WHEELED / ROWTRAC	470 WHEELED / ROWTRAC / QUADTRAC
<b>ENGINE</b>			
Engine Type	Tier 4 B/Final with Selective Catalytic Reduction (SCR)-only emissions system		
Engine HP @ Rated RPM per SAE	370 @ 2,000 RPM	420 @ 2,100 RPM	470 @ 2,100 RPM
Maximum Engine HP per SAE	425	462	517
Engine HP @ Rated RPM per ECE120	375 @ 2,000 RPM	426 @ 2,100 RPM	477 @ 2,100 RPM
Maximum Engine HP per ECE120	431	468	524
HP @ Standard PTO speed @ 1,000 RPM	364	407	459
Cylinders / Valves / Displacement	6 cyl. / 24 / 8.7 L (531 cu. in.)	6 cyl. / 24 / 12.9 L (787 cu. in.)	
Engine Aspiration	Electrical variable geometry turbocharger with air-to-air aftercooling	Wastegate turbocharger with air-to-air aftercooling	
Factory-Installed Engine Brake	N/A	Standard	
<b>ELECTRICAL</b>			
Alternator / Battery / Battery Isolator	12V 240 amp / two 1,000 cranking amps / Yes		
<b>TRANSMISSION/PTO</b>			
Transmission (Standard / Optional)	PowerDrive full-powershift 16F / 2R with 16 Hi {25 mph (40 kph)} / CVXDrive CVT {25 mph (40 kph)}		
PTO—Optional	1,000 rpm—1 3/4 in. shaft		
<b>AXLES</b>			
Axle Diameter	5.0 in. (127 mm) planetary	5.0 in. (127 mm) planetary/flanged	5.0 in. (127 mm) planetary/flanged/flanged
Axle Bar Width (Wheeled) / Track Spacing (Rowtrac/Quadtrac)**	120 in. (3 048 mm) / N/A / N/A	120 in. (3 048 mm) / 80 in. (2 032 mm), 88 in. (2 235 mm) or 120 in. (3 048 mm) / N/A	120 in. (3 048 mm) / 80 in. (2 032 mm), 88 in. (2 235 mm) or 120 in. (3 048 mm) / 88 in. (2 235 mm)
Wheelbase	148 in. (3 759 mm)	148 in. (3 759 mm) / 160 in. (4 064 mm)	148 in. (3 759 mm) / 160 in. (4 064 mm) / 154 in. (3 912 mm)
Automatic Differential Lock	Standard		
<b>HYDRAULICS</b>			
Remote Valves (Standard / Optional)	4 / up to 8		
Hydraulic Pump (PFC)—PowerDrive (Standard / Optional)	40 gpm (151 L/min.) / 55 gpm (208 L/min.)	42 gpm (159 L/min.) / 57 gpm (216 L/min.)	
Hydraulic Pump (PFC)—CVXDrive Standard	55 gpm (208 L/min.)	57 gpm (216 L/min.)	
Total Tractor Hydraulic Flow with Parallel / Twin Flow Pumps	108 gpm (409 L/min.)	113 gpm (428 L/min.)	
Available Flow at Single Remote Valve	35 gpm (132 L/min.)		
Drawbar (Standard / Optional)	6,000 lb. (2 722 kg) or 11,000 lb. (4 990 kg)		6,000 lb. (2 722 kg) or 11,000 lb. (4 990 kg) or 15,000 lb. (6 804 kg) Quadtrac or Wheeled option
3-Point Hitch Category (Wheeled / Rowtrac / Quadtrac)	Cat. 4N† / N/A / N/A	Cat. 4N† / Cat. 4N† / N/A	Cat. 4N† / Cat. 4N† / Cat. 4N
Hitch Lift Capacity (Wheeled / Rowtrac / Quadtrac)	21,903 lb. (9 934 kg)		21,903 lb. (9 934 kg) / 21,903 lb. (9 934 kg) / 19,728 lb. (8 949 kg)
<b>CAPACITIES</b>			
Fuel Tank (Wheeled / Rowtrac / Quadtrac)	220 gal. (829 L) / N/A / N/A	310 gal. (1 170 L) / 340 gal. (1 287 L) standard or 250 gal. (946 L) optional / N/A	310 gal. (1 170 L) / 340 gal. (1 287 L) standard or 250 gal. (946 L) optional / 470 gal. (1 779 L)
Diesel Exhaust Fluid (DEF) Tank (Wheeled / Rowtrac / Quadtrac)	42 gal. (174 L) / 42 gal. (174 L) / N/A		42 gal. (174 L) / 42 gal. (174 L) / 85 gal. (322 L)
Vertical Tongue (Wheeled / Rowtrac / Quadtrac)	Up to 11,000 lb. (4 990 kg) / up to 11,000 lb. (4 990 kg) / N/A		Up to 11,000 lb. (4 990 kg) / up to 11,000 lb. (4 990 kg) / up to 15,000 lb. (6 804 kg)
Frame Width (Wheeled / Rowtrac / Quadtrac)	36.5 in. (927 mm) / N/A / N/A	36.5 in. (927 mm) / 36.5 in. (927 mm) / N/A	36.5 in. (927 mm) / 36.5 in. (927 mm) / 44 in. (1 118 mm)
<b>CAB</b>			
Volume (Size)	132 cu. ft. (3.7 cu. m)		
Glass	88.1 sq. ft. (8.18 sq. m)		
<b>WEIGHTS</b>			
Wheel Models—Base Shipping Weight	38,571 lb. (17 496 kg)	39,820 lb. (18 062 kg)	
Wheel Models—Max. Gross Vehicle Weight	49,500 lb. (22 453 kg)		
Rowtrac Models—Base Shipping Weight	N/A	50,306 lb. (22 818 kg)	
Rowtrac Models—Max. Gross Vehicle Weight	N/A	60,000 lb. (27 216 kg)	
Quadtrac Models—Base Shipping Weight	N/A	N/A	51,263 lb. (23 416 kg)
Quadtrac Models—Max. Gross Vehicle Weight	N/A	N/A	64,000 lb. (29 630 kg)

\*Designated for commercial use only \*\*All wheeled Steigers have bar axles and all Quadtrac and Rowtrac Steigers have flanged axles † Convertible to Cat. 3



SPECIFICATIONS	500 WHEELED/ROWTRAC/QUADTRAC*	540 WHEELED/QUADTRAC*	580 WHEELED/QUADTRAC*	620 WHEELED/QUADTRAC*
<b>ENGINE</b>				
Engine Type	Tier 4 B/Final with Selective Catalytic Reduction (SCR)-only emissions system			
Engine HP @ Rated RPM per SAE	500 @ 2,100 RPM	535 @ 2,100 RPM	580 @ 2,100 RPM	620 @ 2,100 RPM
Maximum Engine HP per SAE	550	605	638	682
Engine HP @ Rated RPM per ECE120	507 @ 2,100 RPM	542 @ 2,100 RPM	588 @ 2,100 RPM	629 @ 2,100 RPM
Maximum Engine HP per ECE120	558	613	647	692
HP @ Standard PTO speed @ 1,000 RPM	501		535	
Cylinders / Valves / Displacement	6 cyl. / 24 / 12.9 L (787 cu. in.)			
Engine Aspiration	Wastegate turbocharger with air-to-air aftercooling	Two-stage turbocharging with air-to-water intercooling and air-to-water aftercooling		
Factory-Installed Engine Brake	Standard			
<b>ELECTRICAL</b>				
Alternator / Battery / Battery Isolator	12V 240 amp / two 1,000 cranking amps / Yes			
<b>TRANSMISSION/PTO</b>				
Transmission (Standard / Optional)	PowerDrive full-powershift 16F / 2R with 16 Hi {25 mph (40 kph)} / CVXDrive CVT (25 mph (40 kph))		PowerDrive full-powershift 16F / 2R w/16 Hi {25 mph (40 kph)}	
PTO—Optional	1,000 rpm—1 3/4 in. shaft			
<b>AXLES</b>				
Axle Diameter	5.0 in. (127 mm) compound planetary/flanged/flanged	5.0 in. (127 mm) compound planetary/flanged	5.5 in. (140 mm) compound planetary/flanged	
Axle Bar Width (Wheeled) / Track Spacing (Rowtrac/Quadtrac)**	120 in. (3,048 mm) / 80 in. (2,032 mm), 88 in. (2,235 mm) or 120 (3,048 mm) / 88 in. (2,235 mm)	120 in. (3,048 mm) / 88 in. (2,235 mm)		
Wheelbase	154 in. (3,912 mm) / 160 in. (4,064 mm) / 154 in. (3,912 mm)	154 in. (3,912 mm)		
Automatic Differential Lock	Standard			
<b>HYDRAULICS</b>				
Remote Valves (Standard / Optional)	4 / up to 8			
Hydraulic Pump (PFC) - PowerDrive (Standard / Optional)	42 gpm (159 L/min.) / 57 gpm (216 L/min.)			
Hydraulic Pump (PFC) - CVXDrive Standard	57 gpm (216 L/min.)		N/A	
Total Tractor Hydraulic Flow w/ Parallel / Twin Flow Pumps	113 gpm (428 L/min.)			
Available Flow at Single Remote Valve	35 gpm (132 L/min.)			
Drawbar (Standard / Optional)	6,000 lb. (2,722 kg) / 11,000 lb. (4,990 kg) or 15,000 lb. (6,804 kg) Quadtrac or wheeled option	6,000 lb. (2,722 kg) or 11,000 lb. (4,990 kg) or 15,000 lb. (6,804 kg)	11,000 lb. (4,990 kg) / 15,000 lb. (6,804 kg)	
Scraper Drawbar (Wheeled / Rowtrac / Quadtrac)	20,000 lb. (9,072 kg) / N/A / N/A	20,000 lb. (9,072 kg) / N/A / 20,000 lb. (9,072 kg)	20,000 lb. (9,072 kg) / N/A / 20,000 lb. (9,072 kg)	20,000 lb. (9,072 kg) / N/A / N/A
3-Point Hitch Category (Wheeled / Rowtrac / Quadtrac)	Cat. 4N† / Cat. 4N† / Cat. 4N			
Hitch Lift Capacity (Wheeled / Rowtrac / Quadtrac)	19,620 lb. (8,900 kg) / 21,903 lb. (9,934 kg) / 19,728 lb. (8,949 kg)	19,620 lb. (8,900 kg) / N/A / 19,728 lb. (8,949 kg)		
<b>CAPACITIES</b>				
Fuel Tank (Wheeled / Rowtrac / Quadtrac)	455 gal. (1,722 L) / 340 gal. (1,287 L) std. and 250 gal. (946 L) opt. / 470 gal. (1,779 L)	455 gal. (1,722 L) / N/A / 470 gal. (1,779 L)		
Diesel Exhaust Fluid (DEF) Tank (Wheeled / Rowtrac / Quadtrac)	66 gal. (250 L) / 42 gal. (174 L) / 85 gal. (322 L)	66 gal. (250 L) / N/A / 85 gal. (322 L)		
Vertical Tongue (Wheeled / Rowtrac / Quadtrac)	Up to 15,000 lb. (6,804 kg) / up to 11,000 lb. (4,990 kg) / up to 15,000 lb. (6,804 kg)	Up to 15,000 lb. (6,804 kg)		
Frame Width (Wheeled / Rowtrac / Quadtrac)	44 in. (1,118 mm) / 36.5 in. (927 mm) / 44 in. (1,118 mm)	44 in. (1,118 mm) / N/A / 44 in. (1,118 mm)		
<b>CAB</b>				
Volume (Size)	132 cu. ft. (3.7 cu. m)			
Glass	88.1 sq. ft. (8.18 sq. m)			
<b>WEIGHTS</b>				
Wheel Models—Base Shipping Weight	44,290 lb. (20,090 kg)	46,340 lb. (21,012 kg)	50,328 lb. (22,828 kg)	
Wheel Models—Max. Gross Vehicle Weight	56,000 lb. (25,401 kg)	56,000 lb. (22,401 kg)	66,000 lb. (29,937 kg)	
Rowtrac Models—Base Shipping Weight	50,306 lb. (22,818 kg)	N/A		
Rowtrac Models—Max. Gross Vehicle Weight	60,000 lb. (27,216 kg)	N/A		
Quadtrac Models—Base Shipping Weight	51,623 lb. (23,416 kg)	52,621 lb. (23,868 kg)	53,503 lb. (24,629 kg)	
Quadtrac Models—Max. Gross Vehicle Weight	64,000 lb. (29,030 kg)			

\*Designated for commercial use only \*\*All wheeled Steigers have bar axles and all Quadtrac and Rowtrac Steigers have flanged axles † Convertible to Cat. 3

MAGNUM MODEL	MAGNUM 180	MAGNUM 200	MAGNUM 220	MAGNUM 240
<b>ENGINE</b>				
Engine Type	Tier 4 B/Final with Selective Catalytic Reduction (SCR)			
Engine HP (Magnum 180–240) ISO/ECE R120 (CV)	180 @ 2,100 RPM	200 @ 2,100 RPM	220 @ 2,100 RPM	240 @ 2,100 RPM
Maximum Engine HP ISO/ECE R120 (CV)	200 @ 1,800 RPM	220 @ 1,800 RPM	240 @ 1,800 RPM	260 @ 1,800 RPM
Maximum Boosted Engine HP ISO/ECE R120 (CV)	225 @ 1,800 RPM	245 @ 1,800 RPM	260 @ 1,800 RPM	270 @ 1,800 RPM
PTO HP @ Rated 2,100 RPM (Magnum 180–240) per SAE	155	170	185	205
Cylinders/Number of Valves/Displacement	6 cyl./24 valves/6.7 L			
Engine Aspiration	Turbocharger wastegate			
Engine Compression Brake	NA			
<b>ELECTRICAL</b>				
Alternator/Battery	12-volt batteries (200 amp)			
<b>TRANSMISSION/PTO</b>				
PowerDrive Powershift: 18 Speed – 25 mph (40 kph)	NA			
PowerDrive Powershift: 19 Speed (Economy) – 25 mph (40 kph)	Standard		NA	
PowerDrive Powershift: 19 Speed – 30 mph (50 kph)	Optional		NA	
CVXDrive Transmission: 25 mph (40 kph)	Optional		Standard	
CVXDrive Transmission: 30 mph (50 kph)	Optional			
Rear PTO – Standard/Optional	540/1,000 RPM 1 3/8 in. (35 mm) shafts /NA			
<b>AXLES</b>				
Rear Axle Diameter – Standard/Optional	4 in. (100 mm)/NA			
Rear Axle Length – Standard/Optional	119 in. (3 020 mm)/112 in. (2 489 mm)			
Suspended Front Axle	Optional			
MFD Tread Adjustability	60–88 in. (1 524–2 235 mm)			
MFD Duals	Optional on class 4.75 axles			
Wheelbase – PowerDrive	118 in. (3 000 mm)			
Wheelbase – CVXDrive	118 in. (3 000 mm)			
<b>HYDRAULICS/HITCH</b>				
System Type	Pressure Flow Compensating (PFC)			
Remotes – Standard/Optional	3, 4 or 5 Electrohydraulic			
Main Implement Pump Flow	37 gpm (140 L/min) / 39 gpm (147 L/min)			
<b>CAPACITIES</b>				
Fuel Tank	160 gal. (600 L)			
Diesel Exhaust Fluid (DEF) Tank	17.5 gal. (66 L)			
<b>CAB</b>				
Cab Suspension	Optional			
Volume (Size)/Glass (Area)/Cab Sound Level	109.5 cu ft. (3.1 m <sup>3</sup> /68.5 sq. ft.) /67 dBa			
<b>WEIGHT</b>				
Average Shipping Weight	21,500 lb. (9 750 kg)			

MAGNUM MODEL	MAGNUM 250	MAGNUM 280	MAGNUM 310	MAGNUM 340	MAGNUM 380
<b>ENGINE</b>					
Engine Type	Tier 4 B/Final with Selective Catalytic Reduction (SCR)				
Engine HP	250 @ 2,000 RPM	280 @ 2,000 RPM	310 @ 2,000 RPM	340 @ 2,000 RPM	380 @ 2,000 RPM
Maximum Engine HP ISO/ECE R120 (CV)	285 @ 1,800 RPM	315 @ 1,800 RPM	345 @ 1,800 RPM	375 @ 1,800 RPM	415 @ 1,800 RPM
Maximum Boosted Engine HP ISO/ECE R120 (CV)	320 @ 1,800 RPM	350 @ 1,800 RPM	380 @ 1,800 RPM	410 @ 1,800 RPM	435 @ 1,800 RPM
PTO HP (Magnum 250 – 380) per SAE	205 @ 2,000 RPM	235 @ 2,000 RPM	265 @ 2,000 RPM	290 @ 2,000 RPM	315 @ 2,000 RPM
Cylinders/Number of Valves/Displacement	6 cyl./24 valves/8.7 L				
Engine Aspiration	Turbocharger wastegate	Turbocharger eVGT			
Engine Compression Brake	Optional				
<b>ELECTRICAL</b>					
Alternator/Battery	200 amp/2 12-volt batteries				
<b>TRANSMISSION/PTO</b>					
PowerDrive Powershift: 18 Speed – 25 mph (40 kph)	Optional			NA	
PowerDrive Powershift: 19 Speed (Economy) – 25 mph (40 kph)	Standard			NA	
PowerDrive Powershift: 19 Speed – 30 mph (50 kph)	Optional			NA	
CVXDrive Transmission: 25 mph (40 kph)	Optional			Standard	
CVXDrive Transmission: 30 mph (50 kph)	Optional				
Rear PTO – Standard/Optional	540/1,000 RPM 1 3/8 in. (35 mm) shafts /NA				
<b>AXLES</b>					
Rear Axle Diameter – Standard/Optional	4 in. (100 mm)/4.5 in. (115 mm)		4.5 in. (115 mm)/NA		5 in. (127 mm)/NA
Rear Axle Length – Standard	120 in. (3 050 mm)/NA				
Suspended Front Axle	Optional				
MFD Tread Adjustability	60–88 in. (1 524–2 235 mm)				
MFD Duals	Optional on Class 4.75 and Class 5 axles				
Wheelbase – PowerDrive	120 in. (3 050 mm)			NA	
Wheelbase – CVXDrive	122 in. (3 100 mm)			124 in. (3 150 mm)	
<b>HYDRAULICS/HITCH</b>					
System Type	Pressure Flow Compensating (PFC)				
Remotes – Standard/Optional	4 Electrohydraulic /5 or 6 Electrohydraulic				
Main Implement Pump Flow	59 gpm (225 L/min.) or 75 gpm (282 L/min.)				
<b>CAPACITIES</b>					
Fuel Tank	PowerDrive: 179 gal. (678 L)/CVXDrive: 163 gal. (617 L)				
Diesel Exhaust Fluid (DEF) Tank	26 gal. (99 L)				
<b>CAB</b>					
Cab Suspension	Optional				
Volume (Size)/Glass (Area)/Cab Sound Level	109.5 cu ft. (3.1 m <sup>3</sup> )/68.5 sq. ft./67 dBA				
<b>WEIGHT</b>					
Average Standard Weight	28,600 lb. (12 973 kg)	28,800 lb. (13 082 kg)	29,600 lb. (13 458 kg)	32,200 lb. (14 148 kg)	



caseih.com

SAFETY NEVER HURTS!™ Always read the Operators Manual before operating any equipment. Inspect equipment before using it, and be sure it is operating properly. Follow the product safety signs, and use any safety features provided. CNH Industrial America LLC reserves the right to make improvements in design and changes in specifications at any time without notice and without incurring any obligation to install them on units previously sold. Specifications, descriptions and illustrative material herein are as accurate as known at time of publication, but are subject to change without notice. Availability of some models and equipment builds varies according to the country in which the equipment is used.

©2023 CNH Industrial America LLC. All rights reserved. Case IH is a trademark registered in the United States and many other countries, owned by or licensed to CNH Industrial N.V., its subsidiaries or affiliates. Any trademarks referred to herein, in association with goods and/or services of companies other than CNH Industrial America LLC, are the property of those respective companies. Printed in U.S.A. www.caseih.com CIH23020101

