

# Farm King

## OPERATOR AND PARTS MANUAL

### Round Bale Carrier

Model 2400





**TABLE OF CONTENTS**

**Manufacturer’s Statement:** For technical reasons, Buhler Industries Inc. reserves the right to modify machinery design and specifications provided herein without any preliminary notice. Information provided herein is of descriptive nature. Performance quality may depend on bale structure, applied techniques, weather conditions and other factors.

INTRODUCTION .....7

SAFETY .....11

ASSEMBLY .....21

OPERATION .....33

MAINTENANCE .....49

PARTS IDENTIFICATION .....61

SPECIFICATIONS .....95

WARRANTY .....105

ALPHABETICAL INDEX .....109

# Farm King



## WARRANTY REGISTRATION FORM

This form must be filled out by the dealer and signed by both the dealer and the customer at the time of delivery.

Customer Name:		Dealer Name:	
_____		_____	
Customer Address:		Dealer Address:	
_____		_____	
City:	Prov / State:	City:	Prov / State:
_____	_____	_____	_____
Postal / Zip Code:	Phone:	Postal / Zip Code:	Phone:
_____	_____	_____	_____

Equipment Name Model:	Serial Number:	Delivery Date:
_____	_____	_____

I have thoroughly instructed the buyer on the above described equipment which review included the Operator's Manual content, equipment care, adjustments, safe operation and applicable warranty policy.

### Dealer Inspection Report

<input type="checkbox"/>	Bearing Seals
<input type="checkbox"/>	Lubricate Machine
<input type="checkbox"/>	Wheel Bolt Torque
<input type="checkbox"/>	Fasteners Tight
<input type="checkbox"/>	Pusher Sprocket And Chain Tension
<input type="checkbox"/>	Hydraulic Hoses
<input type="checkbox"/>	Electrical Harnesses
<input type="checkbox"/>	Tire Pressure

### Safety

<input type="checkbox"/>	All Lights And Reflectors Installed
<input type="checkbox"/>	All Lights And Reflectors Cleaned And Working
<input type="checkbox"/>	Safety Chain On Hitch
<input type="checkbox"/>	All Decals Installed
<input type="checkbox"/>	Guards And Shields Installed And Secure
<input type="checkbox"/>	Review Operating And Safety Instructions
<input type="checkbox"/>	General Adjustment And Set-up Procedures
<input type="checkbox"/>	Transportation Requirements And Regulations

Date:	Dealer Rep. Signature:
_____	_____

The above equipment and Operator And Parts Manual have been received by me and I have been thoroughly instructed as to care, adjustments, safe operation and applicable warranty policy.

Date:	Customer / Owner's Signature:
_____	_____

Remove this Warranty Registration Form from the Operator And Parts Manual. Make two copies of the form. Send original Warranty Registration Form to Farm King. Give one copy to the customer and the dealer will keep one copy.

# Farm King



**INTRODUCTION**

This Operator And Parts Manual was written to give the owner / operator instructions on the safe operation, maintenance and part identification of the Farm King equipment. **READ AND UNDERSTAND THIS OPERATOR AND PARTS MANUAL BEFORE OPERATING YOUR FARM KING EQUIPMENT.** If you have any questions, see your Farm King dealer. This manual may illustrate options and accessories not installed on your Farm King equipment.

**OWNER'S INFORMATION** .....9  
    Serial Number Location .....9  
    Manual Storage .....9

**EQUIPMENT IDENTIFICATION** .....10  
    Component Location .....10

# Farm King





**OWNER’S INFORMATION**

Thank you for your decision to purchase a Farm King 2400 Round Bale Carrier. To ensure maximum performance of your equipment, it is mandatory that you thoroughly study the Operator And Parts Manual and follow the recommendations. Proper operation and maintenance are essential to maximize equipment life and prevent personal injury.

Operate and maintain this equipment in a safe manner and in accordance with all applicable local, state, and federal codes, regulations and / or laws. Follow all on-product labeling and instructions.

Make sure that all personnel have read this Operator and Parts Manual and thoroughly understand safe and correct operating, installation and maintenance procedures.

Farm King is continually working to improve its products. Farm King reserves the right to make any improvements or changes as deemed practical and possible without incurring any responsibility or obligation to make any changes or additions to equipment sold previously.

Although great care has been taken to ensure the accuracy of this publication, Farm King makes no warranty or guarantee of any kind, written or expressed, implied or otherwise with regard to the information contained within this manual. Farm King assumes no responsibility for any errors that may appear in this manual and shall not be liable under any circumstances for incidental, consequential or punitive damages in connection with, or arising from the use of this manual.

Keep this manual available for frequent reference. All new operators or owners must review the manual before using the equipment and annually thereafter. Contact your Farm King Dealer if you need assistance, information, or additional copies of the manual. Visit our website at [www.farm-king.com](http://www.farm-king.com) for a complete list of dealers in your area.

The directions left, right, front and rear, as mentioned throughout this manual, are as viewed from the rear of the equipment.

**Serial Number Location**

Please enter the model and serial number in the space provided for easy reference.

**Figure 1**



**Model Number:** \_\_\_\_\_

**Serial Number:** \_\_\_\_\_

The serial number plate (Item 1) [Figure 1] is located on the inside of the left frame forward of the jack.

Always use your serial number when requesting information or when ordering parts.

**Manual Storage**

**Figure 2**

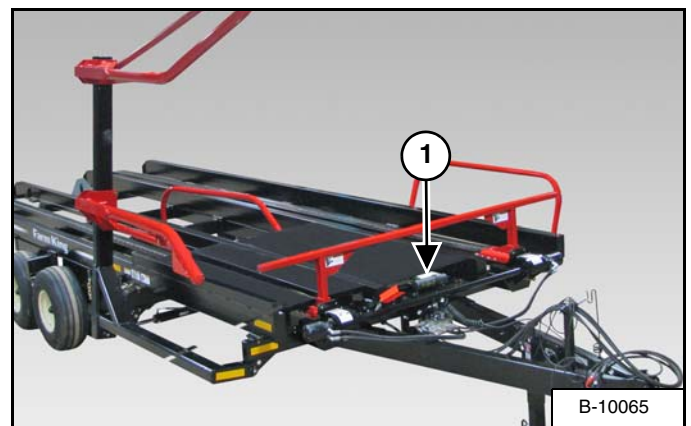

The Operator And Parts Manual and other documents can be stored in the canister (Item 1) [Figure 2] located on the front left side of the carrier.

**EQUIPMENT IDENTIFICATION**

**Component Location**

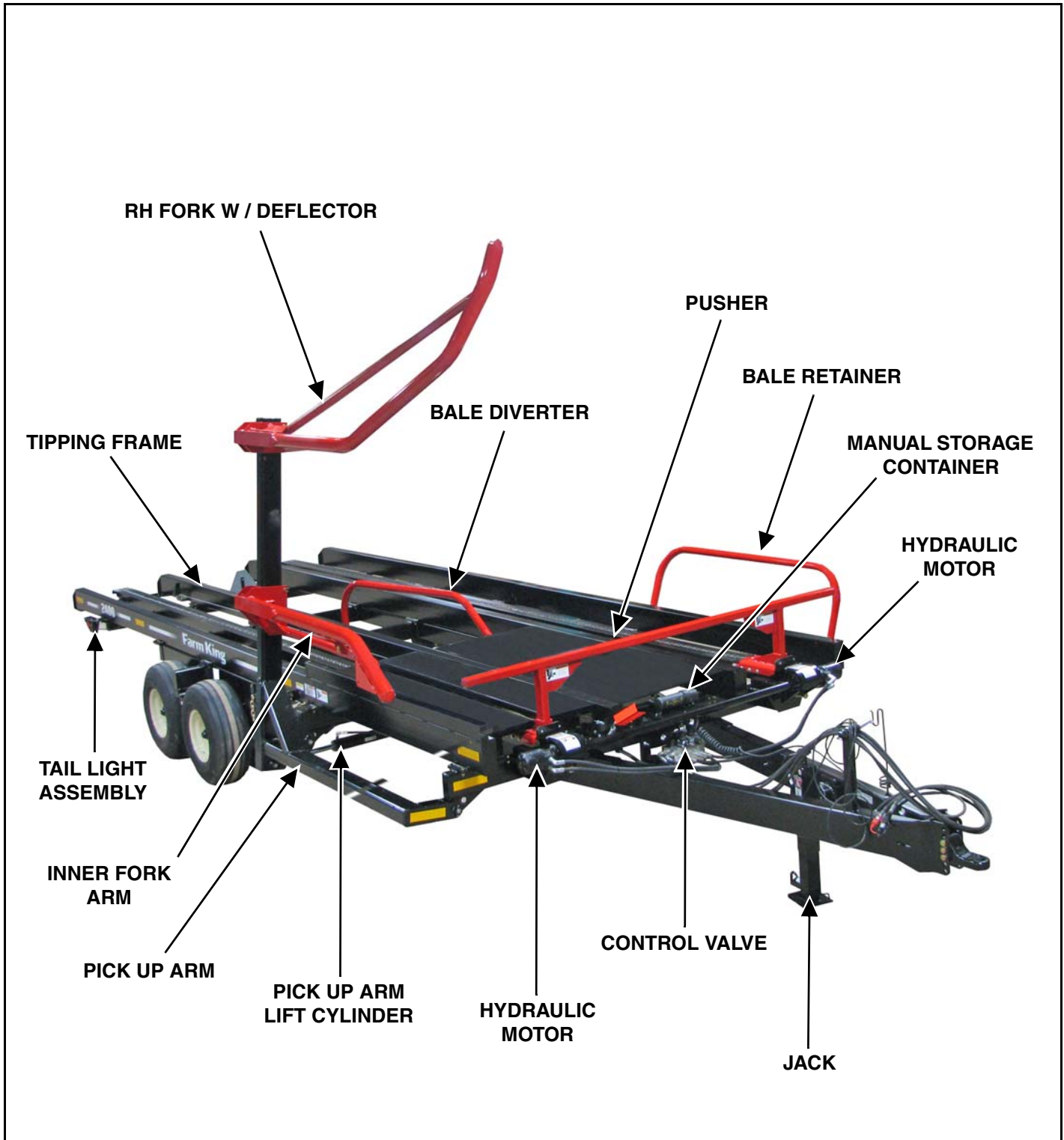

**SAFETY**

SAFETY INSTRUCTIONS ..... 13

- Safe Operation Is The Operator’s Responsibility ..... 13
- Safe Operation Needs A Qualified Operator ..... 13
- Use Safety Rules ..... 14
- Transport Safety ..... 14
- Machine Requirements And Capabilities ..... 15

FIRE PREVENTION ..... 15

- Maintenance ..... 15
- Operation ..... 15
- Starting ..... 15
- Electrical ..... 16
- Hydraulic System ..... 16
- Welding And Grinding ..... 16
- Fire Extinguishers ..... 16

SAFETY SIGNS (DECALS) ..... 17

EQUIPMENT DECALS AND SIGNS ..... 19

SAFETY SIGN-OFF FORM ..... 20

# Farm King



**SAFETY INSTRUCTIONS**

**Safe Operation Is The Operator’s Responsibility**

	<p><b>Safety Alert Symbol</b></p>
<p>This symbol with a warning statement means: “Warning, be alert! Your safety is involved!” Carefully read the message that follows.</p>	



**CAUTION**

The signal word **CAUTION** on the machine and in the manuals indicates a potentially hazardous situation which, if not avoided, may result in minor or moderate injury. It may also be used to alert against unsafe practices.



**DANGER**

The signal word **DANGER** on the machine and in the manuals indicates a hazardous situation which, if not avoided, will result in death or serious injury.



**WARNING**

The signal word **WARNING** on the machine and in the manuals indicates a potentially hazardous situation which, if not avoided, could result in death or serious injury.



**IMPORTANT**

This notice identifies procedures which must be followed to avoid damage to the machine.

**Safe Operation Needs A Qualified Operator**



**WARNING**

**Operators must have instructions before operating the machine. Untrained operators can cause injury or death.**

For an operator to be qualified, he or she must not use drugs or alcoholic drinks which impair alertness or coordination while working. An operator who is taking prescription drugs must get medical advice to determine if he or she can safely operate a machine and the equipment.

*A Qualified Operator Must Do The Following:*

*Understand the Written Instructions, Rules and Regulations*

- The written instructions from Farm King include the Warranty Registration, Dealer Inspection Report, Operator And Parts Manual and machine signs (decals).
- Check the rules and regulations at your location. The rules may include an employer’s work safety requirements. Regulations may apply to local driving requirements or use of a Slow Moving Vehicle (SMV) emblem. Regulations may identify a hazard such as a utility line.

*Have Training with Actual Operation*

- Operator training must consist of a demonstration and verbal instruction. This training is given by the machine owner prior to operation.
- The new operator must start in an area without bystanders and use all the controls until he or she can operate the machine safely under all conditions of the work area. Always fasten seat belt before operating.

*Know the Work Conditions*

- Clear working area of all bystanders, especially small children and all obstacles that might be hooked or snagged, causing injury or damage.
- Know the location of any overhead or underground power lines. Call local utilities and have all underground power lines marked prior to operation.
- Wear tight fitting clothing. Always wear safety glasses when doing maintenance or service.

**SAFETY INSTRUCTIONS (CONT'D)****Use Safety Rules**

- Read and follow instructions in this manual and the tractor's Operators Manual before operating.
- Under no circumstances should young children be allowed to work with this equipment.
- This equipment is dangerous to children and persons unfamiliar with its operation.
- If the elderly are assisting with work, their physical limitations need to be recognized and accommodated.
- Stay clear of overhead power lines when raising tipping frame or lift arm. Electrocutation can occur without direct contact.
- Check for overhead and / or underground lines before operating equipment (if applicable).
- In addition to the design and configuration of equipment, hazard control and accident prevention are dependent upon the awareness, concern, prudence and proper training of personnel involved in the operation, transport, maintenance and storage of equipment.
- Check that the equipment is securely fastened to the tractor / towing vehicle.
- Make sure all the machine controls are in the NEUTRAL position before starting the machine.
- Operate the equipment only from the operator's position.
- Operate the equipment according to the Operator And Parts Manual.
- When learning to operate the equipment, do it at a slow rate in an area clear of bystanders, especially small children.
- DO NOT permit personnel to be in the work area when operating the equipment.
- The equipment must be used ONLY on approved tractors / transport vehicles.
- DO NOT modify the equipment in any way. Unauthorized modification may impair the function and / or safety and could affect the life of the equipment.
- DO NOT make any adjustments or repairs on the equipment while the machine is running.
- Keep shields and guards in place. Replace if damaged.

**Transport Safety**

- DO NOT exceed 20 mph (32 kph). Reduce speed on rough roads and surfaces.
- Comply with state and local laws governing highway safety and movement of machinery on public roads.
- The use of flashing amber lights is acceptable in most localities. However, some localities prohibit their use. Local laws should be checked for all highway lighting and marking requirements.
- Always install transport locks, pins or brackets before transporting.
- Always yield to oncoming traffic in all situations and move to the side of the road so any following traffic may pass.
- Always enter curves or drive up or down hills at a low speed and at a gradual steering angle.
- Never allow riders on either tractor or equipment.
- Keep tractor / towing vehicle in a lower gear at all times when traveling down steep grades.
- Maintain proper brake settings at all times (if equipped).
- Stay away from overhead power lines when tipping frame or lift arm is raised. Electrocutation can occur without direct contact.

## Machine Requirements And Capabilities

- Stop the machine and engage the parking brake. Install blocks in front of and behind the rear tires of the machine. Install blocks underneath and support the equipment securely before working under raised equipment.
- Keep bystanders clear of moving parts and the work area. Keep children away.
- Use increased caution on slopes and near banks and ditches to prevent overturn.
- Make certain that the Slow Moving Vehicle (SMV) emblem is installed so that it is visible and legible. When transporting the equipment, use the flashing warning lights (if equipped) and follow all local regulations.
- Operate this equipment with a machine equipped with an approved Roll-Over Protective Structure (ROPS). Always wear seat belt when the ROPS is up. Serious injury or death could result from falling off the machine.
- Before leaving the operator's position:
  1. Always park on a flat level surface.
  2. Place all controls in neutral.
  3. Engage the parking brake.
  4. Stop engine.
  5. Wait for all moving parts to stop.
- Carry passengers only in designated seating areas. Never allow riders on the machine or equipment. Falling off can result in serious injury or death.
- Start the equipment only when properly seated in the operator's seat. Starting a machine in gear can result in serious injury or death.
- Operate the machine and equipment from the operator's position only.
- The parking brake must be engaged before leaving the operator's seat. Rollaway can occur because the transmission may not prevent machine movement.

## FIRE PREVENTION



### Maintenance

The machine and some equipment have components that are at high temperatures under normal operating conditions. The primary source of high temperatures is the engine and exhaust system. The electrical system, if damaged or incorrectly maintained, can be a source of arcs or sparks.

Flammable debris (leaves, straw, etc.) must be removed regularly. If flammable debris is allowed to accumulate, it can cause a fire hazard. Clean often to avoid this accumulation.

All fuels, most lubricants and some coolant mixtures are flammable. Flammable fluids that are leaking or spilled onto hot surfaces or onto electrical components can cause a fire.

### Operation

The Farm King machine must be in good operating condition before use.

Check all of the items listed on the service schedule under the 8 hour column. (See "SERVICE SCHEDULE" on page 52.)

Do not use the machine where exhaust, arcs, sparks or hot components can contact flammable material, explosive dust or gases.

### Starting

Use the procedure in the tractor's operator's manual for connecting the battery and for jump starting.

**Electrical**



Check all electrical wiring and connections for damage. Keep the battery terminals clean and tight. Repair or replace any damaged part or wires that are loose or frayed.

**Hydraulic System**

Check hydraulic tubes, hoses and fittings for damage and leakage. Never use open flame or bare skin to check for leaks. Hydraulic tubes and hoses must be properly routed and have adequate support and secure clamps. Tighten or replace any parts that show leakage.

Always clean fluid spills. Do not use gasoline or diesel fuel for cleaning parts. Use commercial nonflammable solvents.

**Welding And Grinding**

Always clean the machine and equipment, disconnect the battery, and disconnect the wiring from the machine controls before welding. Cover rubber hoses, battery and all other flammable parts. Keep a fire extinguisher near the machine when welding.

Have good ventilation when grinding or welding painted parts. Wear dust mask when grinding painted parts. Toxic dust or gas can be produced.

Dust generated from repairing nonmetallic parts such as hoods, fenders or covers can be flammable or explosive. Repair such components in a well ventilated area away from open flames or sparks.

**Fire Extinguishers**



Know where fire extinguishers and first aid kits are located and how to use them. Inspect the fire extinguisher and service the fire extinguisher regularly. Obey the recommendations on the instructions plate.



**SAFETY SIGNS (DECALS)**

Follow the instructions on all the Signs (Decals) that are on the equipment. Replace any damaged signs (decals) and be sure they are in the correct locations. Equipment signs are available from your Farm King equipment dealer.

Chain Shields



1



p/n 813627

2



p/n 813635

Both Sides Of Pusher (Front)



1

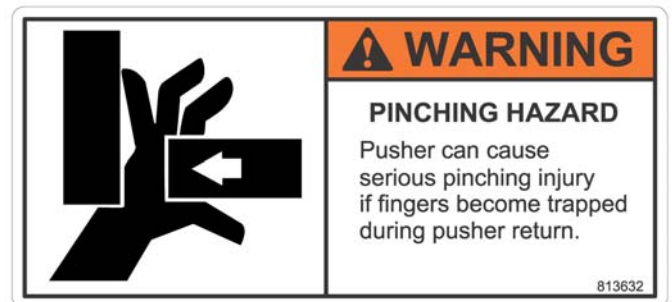

p/n 813632

Right Side Carrier Frame

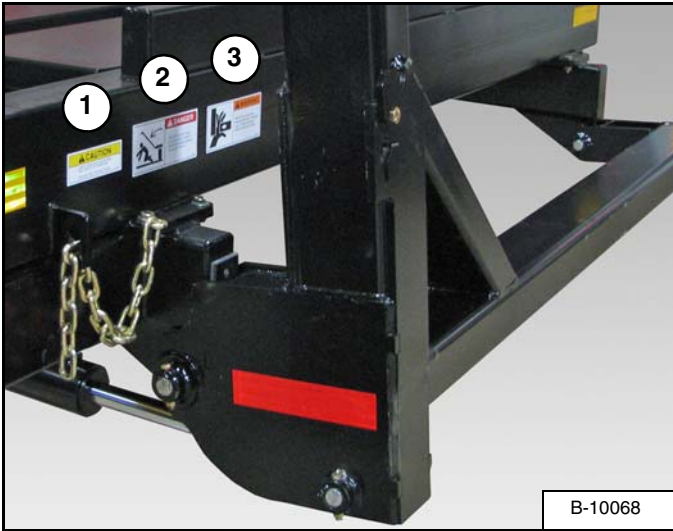

1

 <b>CAUTION</b>	
SAFETY CHAIN MUST BE SECURED AND LOCKED FOR TRANSPORT.	
RELEASE ONLY FOR FIELD WORK.	
813626	

p/n 813626

2

	<b>DANGER</b>  Bale lift arm can cause serious injury or death if person becomes trapped during arm return.  813637
--	---

p/n 813637

3

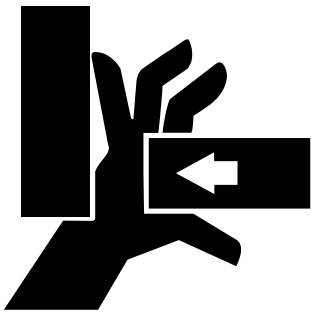
	<b>WARNING</b>  Bale lift arm can cause serious pinching or crushing injury if fingers become trapped during arm return.  813636
---	--

p/n 813636

**EQUIPMENT DECALS AND SIGNS**

**NOTE: All safety related decals are shown in the Safety Signs Section. (See "SAFETY SIGNS (DECALS)" on page 17.)**

Check and replace any worn, torn, hard to read or missing decals on your equipment.

Part Number 815850



Part Number 815004



Part Number 105420



Part Number 967055 (Amber)



Part Number 967053 (Red)



Part Number 813631 (Day Orange)



Part Number 813631 (Orange)



Part Number 21867



Part Number 813633

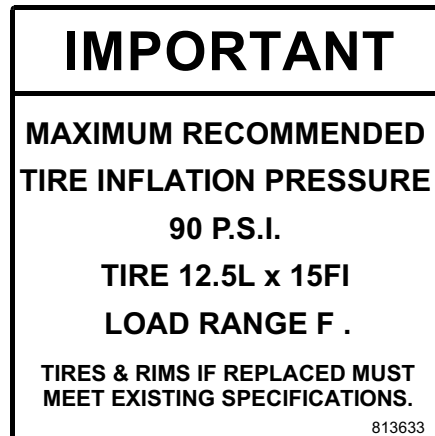

Part Number 813634

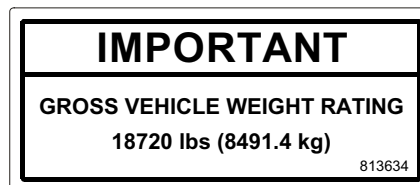

**SAFETY SIGN-OFF FORM**



**Instructions are necessary before operating or servicing equipment. Read and understand the Operator And Parts Manual and safety signs (decals) on equipment. Follow warnings and instructions in the manuals when making repairs, adjustments or servicing. Check for correct function after adjustments, repairs or service. Untrained operators and failure to follow instructions can cause injury or death.**

Farm King follows the general Safety Standards specified by the American Society of Agricultural and Biological Engineers (ASABE) and the Occupational Safety and Health Administration (OSHA). Anyone who will be operating and / or maintaining the 2400 Round Bale Carrier must read and clearly understand ALL Safety, Operating and Maintenance information presented in this manual.

Annually review this information before the season start-up and make these periodic reviews of SAFETY and OPERATION a standard practice for all of your equipment. An untrained operator is unqualified to operate this machine.

The following sign-off sheet is provided for your record and to show that all personnel who will be working with the equipment have read and understand the information in this Operator And Parts Manual and have been instructed in the operation of the equipment.

SIGN-OFF SHEET		
Date	Employee's Signature	Employer's Signature

**ASSEMBLY**

GENERAL ASSEMBLY INFORMATION .....23  
    Component Unloading And Identification .....23

BASE GROUP .....24  
    Installing The Taillight Assembly .....24  
    Installing The Bale Retainer .....26  
    Installing The Pick-Up Arm W / Bale Deflector .....27  
    Adjusting Pick Up Arm Forks .....32

# Farm King



**GENERAL ASSEMBLY INFORMATION**

**Component Unloading And Identification**



**ELECTROCUTION HAZARD**

To prevent serious injury or death from electrocution:

- Be aware of overhead power lines.
- Keep away from power lines when unloading and assembling the bale carrier.
- Electrocution can occur without direct contact.



- DO NOT permit bystanders to be in the work area when unloading and assembling the bale carrier components.
- DO NOT work under suspended parts.
- Keep away from moving parts.
- Always use lifting devices / vehicles, chains or straps of adequate size and strength when unloading and assembling the bale carrier components.

Unload the crate(s) and components on a flat level area of adequate size to assemble the 2400 Round Bale Carrier components.



Unload crate(s) and round bale carrier components carefully to prevent damage to any of the components.

**NOTE: If any components are damaged, missing or replacement parts are required, contact your Farm King Dealer.**

Assemble the 2400 Round Bale Carrier components in the following order:

Using the packing list, locate and place all components and hardware in one area. Count the individual components and verify that you have received the correct number of components to fully assemble the 2400 Round Bale Carrier.

1. Taillight Assembly (See “Installing The Taillight Assembly” on page 24.)
2. Bale Retainer (See “Installing The Bale Retainer” on page 26.)
3. Fixed Loading Arm W/Bale Deflector (See “Installing The Pick-Up Arm W / Bale Deflector” on page 27.)

**BASE GROUP**

**Installing The Taillight Assembly**

Assemble the main frame on a flat level surface.

**NOTE:** The following images throughout the assembly section of this manual may not show your exact round bale carrier components as they appear but the procedure is correct for all 2400 Round Bale Carriers.



- DO NOT permit bystanders to be in the work area when lowering, raising or folding wing.
- DO NOT work under suspended parts.
- Keep away from moving parts.
- Always use lifting devices / vehicles, chains or straps of adequate size and strength when unloading and assembling the bale carrier components.



Always use chains, straps and lifting devices that are in good condition and of adequate size to lift the bale carrier components.

**NOTE:** Support stands approximately 36 inches (914.4 mm) high equipped with rotating casters / wheels are recommended when assembling the main frame of the bale carrier.

Figure 3

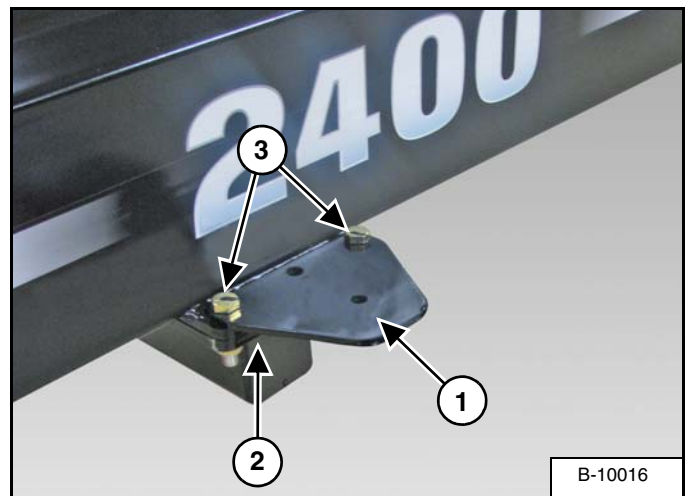

Align the inner light bracket (Item 1) with the top of the mount (Item 2) [Figure 3] on the right rear side of the carrier frame.

Install two 1/2" x 2" bolts (Item 3) [Figure 3] down through the inner light bracket and carrier mount. Install one 1/2" flat washer and 1/2" locknut on each bolt. Tighten bolts and locknuts.

Repeat procedure for LH inner light bracket.



**AVOID INJURY OR DEATH**

Keep fingers and hands out of pinch points when assembling the equipment.



**Figure 4**

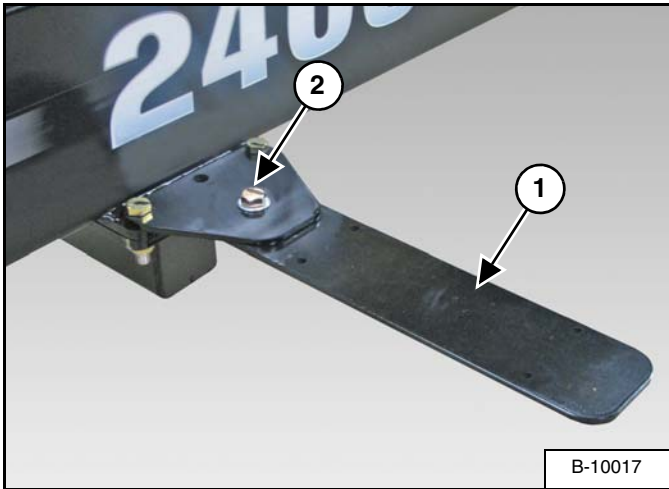

Align and install the outer light bracket (Item 1) [Figure 4] under the inner light bracket.

Install one 1/2" flat washer on a 1/2" x 2" bolt (Item 2) [Figure 4], then install the bolt down through the inner light bracket and outer light bracket. Install one 1/2" flat washer and 1/2" locknut on the bolt. Tighten bolt and locknut until the two light brackets make contact.

**NOTE: Outer light bracket should be able to be rotated in toward the carrier frame. Do Not over-tighten.**

Repeat procedure for LH outer light bracket.

**Figure 5**

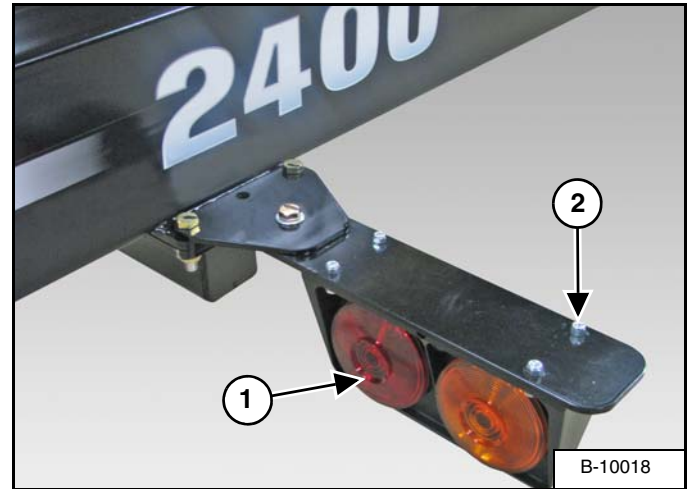

Align and install the RH tail light (Item 1) [Figure 5] (Amber lens to the outside) under the outer light bracket.

Install four 1/4" x 1" bolts (Item 2) [Figure 5] down through the outer light bracket and tail light. Install one 1/4" locknut on each bolt. Tighten bolt and locknut. Do Not over-tighten.

Repeat procedure for LH outer light bracket.

**Figure 6**

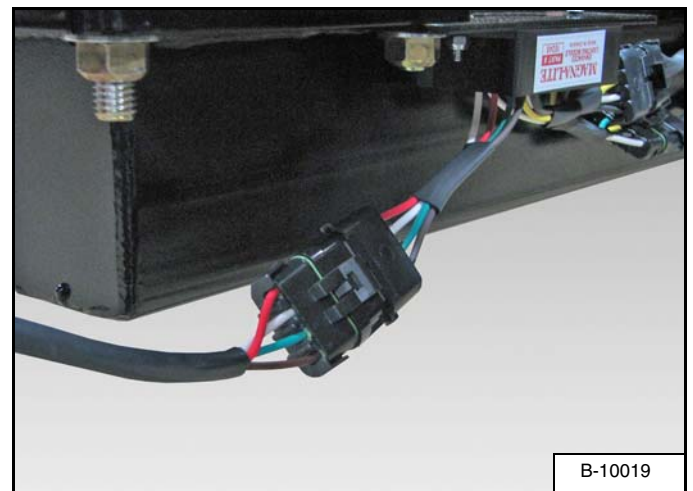

Connect the LH & RH tail light pigtail harnesses to the enhanced ag lighting module electrical harness [Figure 6].

Installing The Bale Retainer

Figure 7

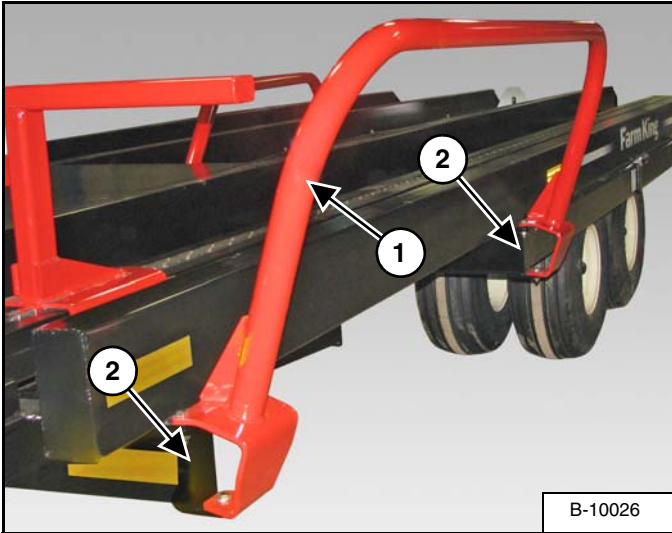

Locate and align the bale retainer (Item 1) with the mounts (Item 2) [Figure 7] on front left side of the carrier frame.

Figure 8

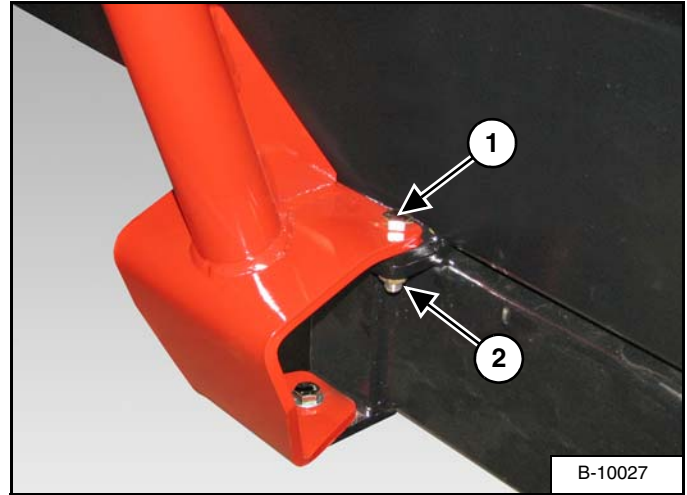

Install three 1/2" x 2" bolt (Item 1) down through the bale retainer mounting bracket and carrier frame mount. Install one 1/2" flat washer and 1/2" locknut (Item 2) [Figure 8] on each bolt. Tighten bolt and locknut.

**Installing The Pick-Up Arm W / Bale Deflector**

Assemble the main frame on a flat level surface.



- DO NOT permit bystanders to be in the work area when lowering, raising or folding wing.
- DO NOT work under suspended parts.
- Keep away from moving parts.
- Always use lifting devices / vehicles, chains or straps of adequate size and strength when unloading and assembling the bale carrier components.



**AVOID INJURY OR DEATH**

Keep fingers and hands out of pinch points when assembling the equipment.

**NOTE:** The following images throughout the assembly section of this manual may not show your exact round bale carrier components as they appear but the procedure is correct for all 2400 Round Bale Carriers.



Always use chains, straps and lifting devices that are in good condition and of adequate size to lift the bale carrier components.

Figure 9

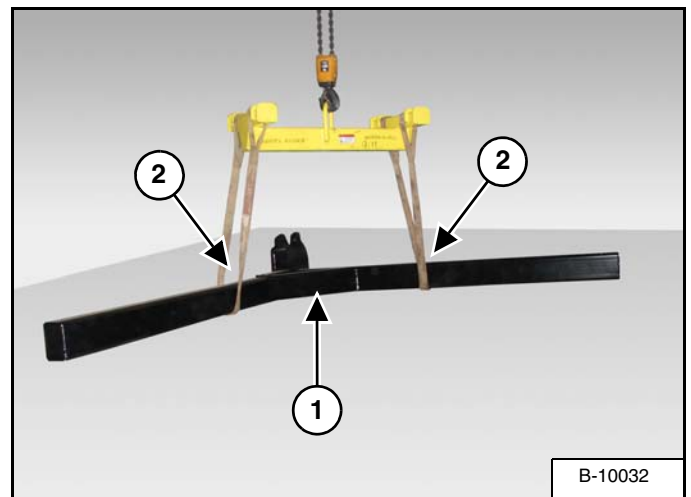

Locate pick-up arm (Item 1). Install straps (Item 2) [Figure 9] around both sides of the pick-up arm (keeping the pick-up arm as level as possible).

Figure 10

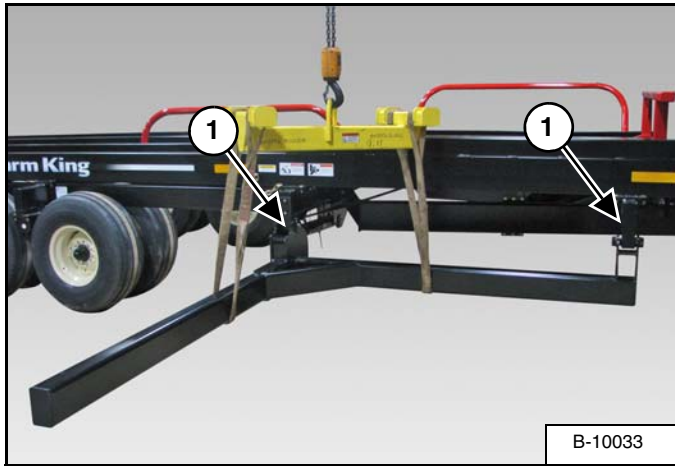

Move the pick-up arm to left front side of the carrier frame. Align the two mounting brackets (Item 1) [Figure 10] with mounts on the left front side of the carrier frame.

Figure 11

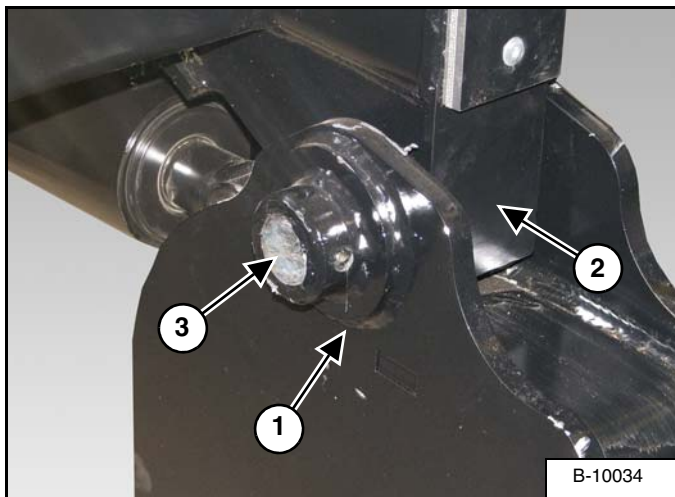

Remove the two 1-1/4 x 6-3/4 inch lift arm pivot pins that are installed in the front and rear pick-up arm mounts on the carrier frame.

Align the rear mounting bracket (Item 1) of the pick-up arm with the hole in the rear pick up arm mount (Item 2) [Figure 11] on the carrier frame.

**NOTE: When installing the 1-1/4 x 6-3/4 inch lift arm pivot pin, maintain hole alignment of the pin and collar on the pick-up arm mounting bracket.**

Install one 1-1/4 x 6-3/4 inch lift arm pivot pin (Item 3) [Figure 11] through the pick-up arm mounting bracket and carrier mount (front to rear, with hole in pin towards the rear).

Figure 12

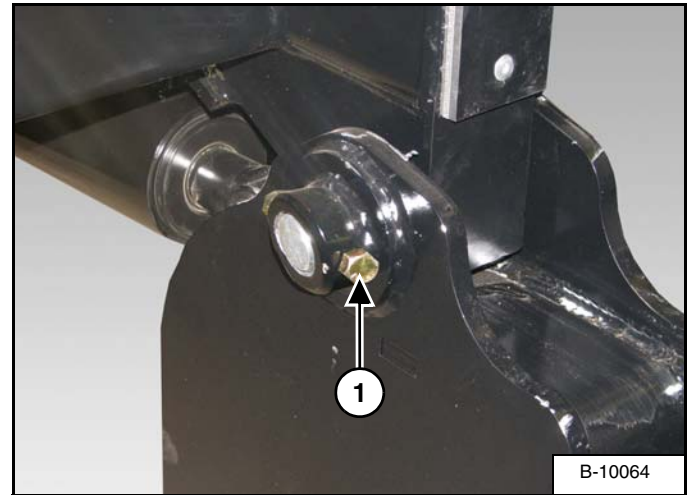

Install one 3/8" x 2-1/2" bolt (Item 1) [Figure 12] through the collar and pin. Install one 3/8" locknut on the bolt and tighten.

Figure 13

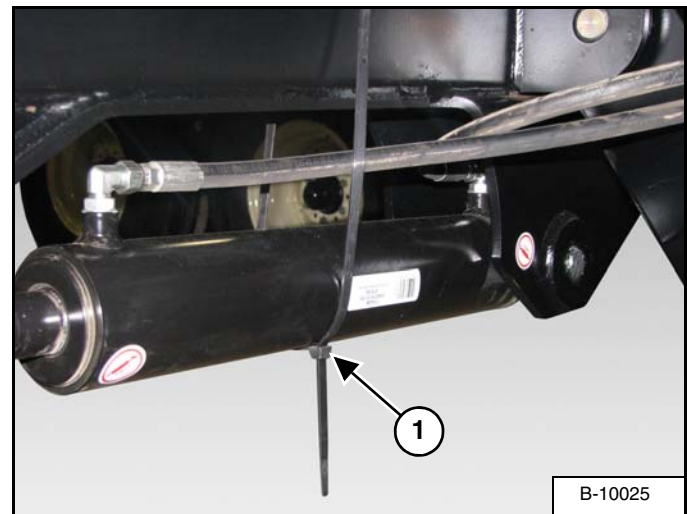

Remove cable tie (Item 1) [Figure 13] from the pick-up arm lift cylinder.

Figure 14

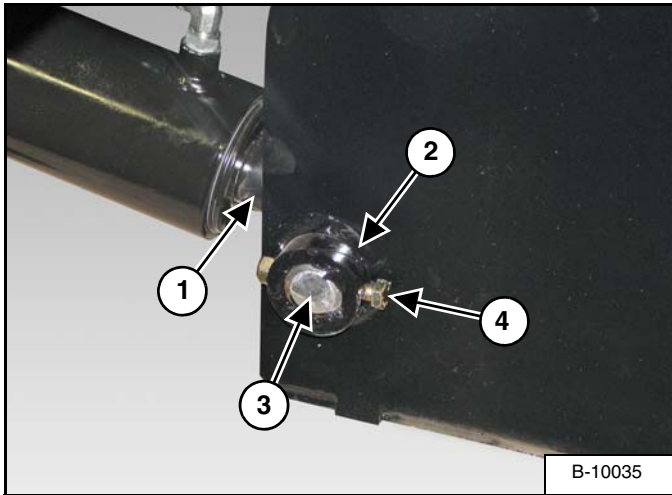

Align the rod end of the pick up lift cylinder (Item 1) with the lower rear pick up arm mount (Item 2) [Figure 14].

**NOTE: When installing the 1-1/4 x 6-3/4 inch lift arm pivot pin, maintain hole alignment of the pin and collar on the pick up arm mount.**

Install one 1-1/4 x 6-3/4 inch pin (Item 3) [Figure 14] through the pick up arm mount and lift cylinder (front to rear, with hole in pin towards the rear).

Install one 3/8" x 2-1/2" bolt (Item 4) [Figure 14] through the collar and pin. Install one 3/8" locknut on the bolt and tighten.

Figure 15

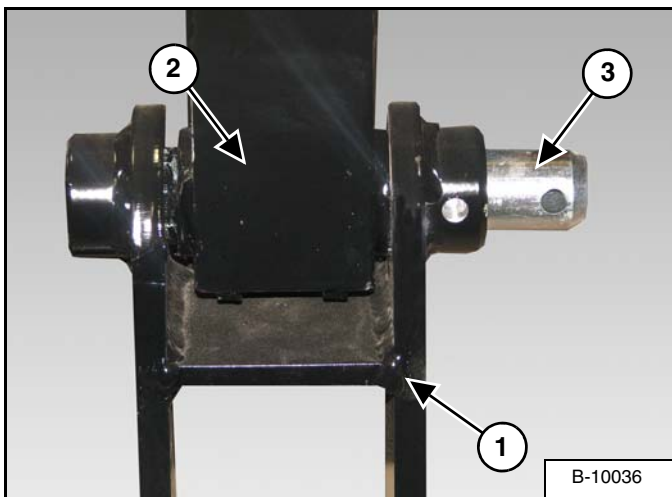

Align the front mounting bracket (Item 1) of the pick up arm with the hole in the rear pick up arm mount (Item 2) [Figure 15] on the carrier frame.

**NOTE: When installing the 1-1/4 x 6-3/4 inch lift arm pivot pin, maintain hole alignment of the pin and collar on the pick up arm mounting bracket.**

Install one 1-1/4 x 6-3/4 inch lift arm pivot pin (Item 3) [Figure 15] through the pick up arm mounting bracket and carrier mount (front to rear, with hole in pin towards the front).

Figure 16

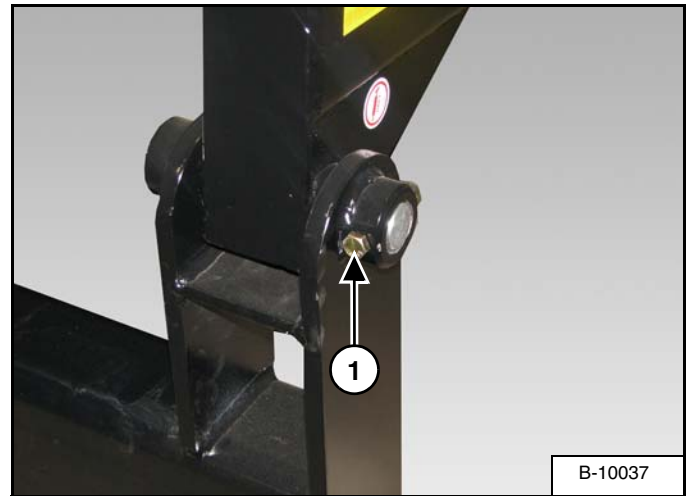

Install one 3/8" x 2-1/2" bolt (Item 1) [Figure 16] through the collar and pin. Install one 3/8" locknut on the bolt and tighten.

Figure 17

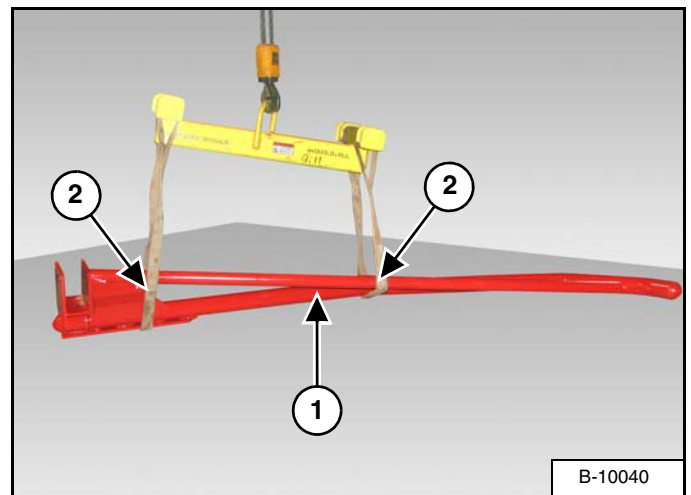

Locate RH fork with deflector (Item 1). Install straps (Item 2) [Figure 17] around the RH fork with deflector (keeping the RH fork with deflector as level as possible).

Raise the pick up arm high enough to allow the RH fork with deflector to be placed under the pick up arm.

**Figure 18**

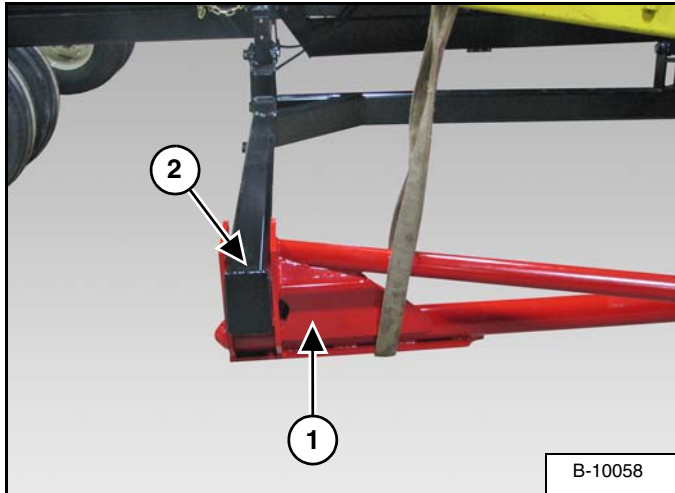

Move the RH fork with deflector (Item 1) in position under the outside of the pick up arm (Item 2) [Figure 18].

**Figure 19**

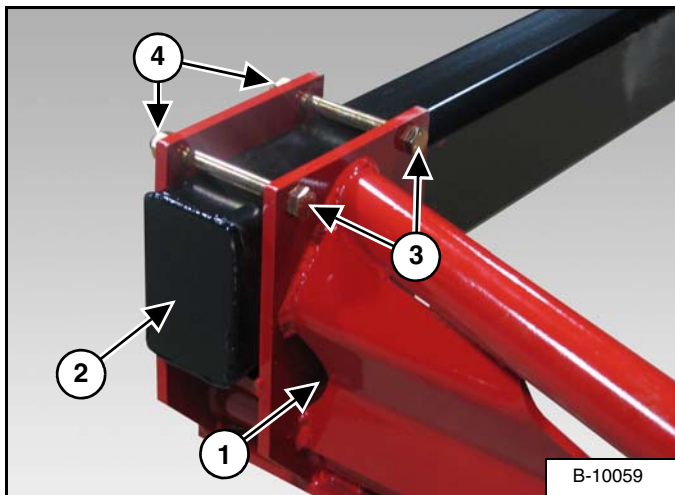

Raise the RH fork with deflector (Item 1) up against the pick up arm (Item 2) [Figure 19].

Install two 5/8" x 6" bolts (Item 3) [Figure 19] through the RH fork with deflector mounting bracket (over the pick up arm)

**NOTE: Locate the RH fork with deflector approximately 1-1/2" in from the outer end of the pick up arm.**

Install one 5/8" flat washer and 5/8" nut (Item 4) [Figure 19] on the each bolt and tighten.

**Figure 20**

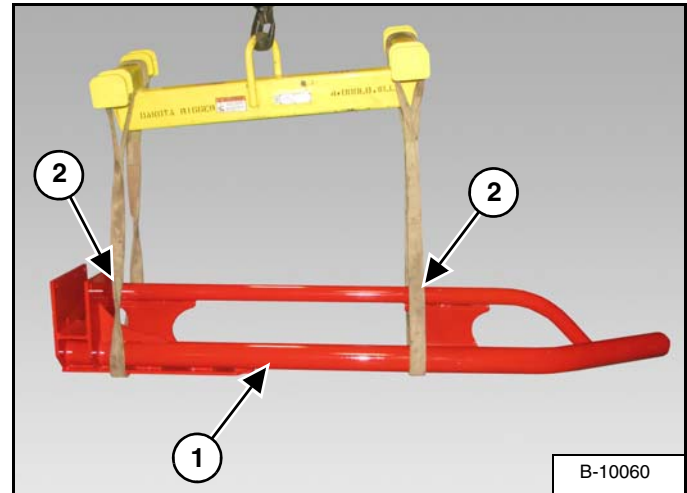

Locate inside fork arm (Item 1). Install straps (Item 2) [Figure 20] around the inside fork arm (keeping the inside fork arm as level as possible).

**Figure 21**

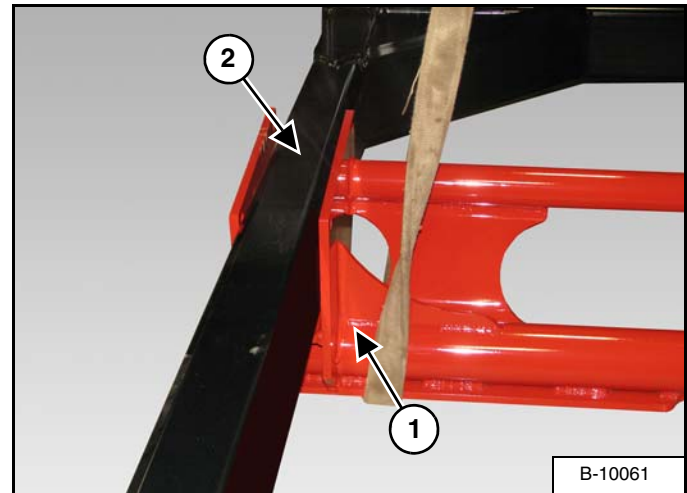

Move the inside fork arm (Item 1) in position under the pick up arm (Item 2) [Figure 21] (towards the inside corner).

Figure 22

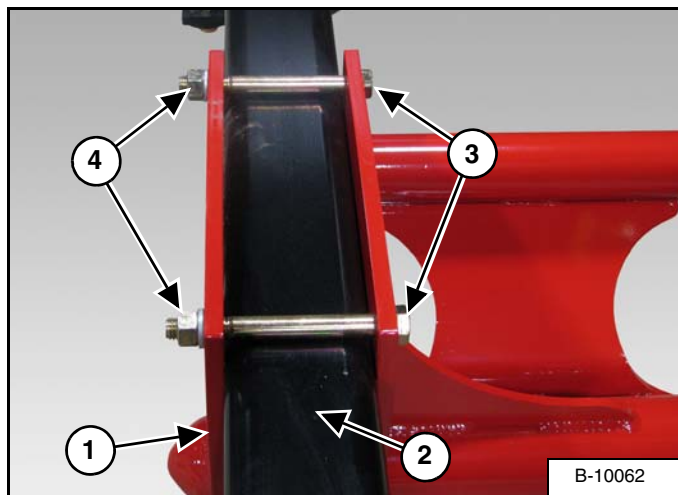

Raise the inside fork arm (Item 1) up against the pick up arm (Item 2) [Figure 22].

Install two 5/8" x 6" bolts (Item 3) [Figure 22] through the inside fork arm mounting bracket (over the pick up arm)

Install one 5/8" flat washer and 5/8" nut (Item 4) [Figure 22] on the each bolt. Do not fully tighten at this time.

**NOTE:** Tighten the 5/8" x 6" bolts just enough to keep the inside fork arm from sliding down the pick up arm when the pick up arm is raised to adjust the inner fork arm with the carrier deck.

**Adjusting Pick Up Arm Forks**

**Figure 23**

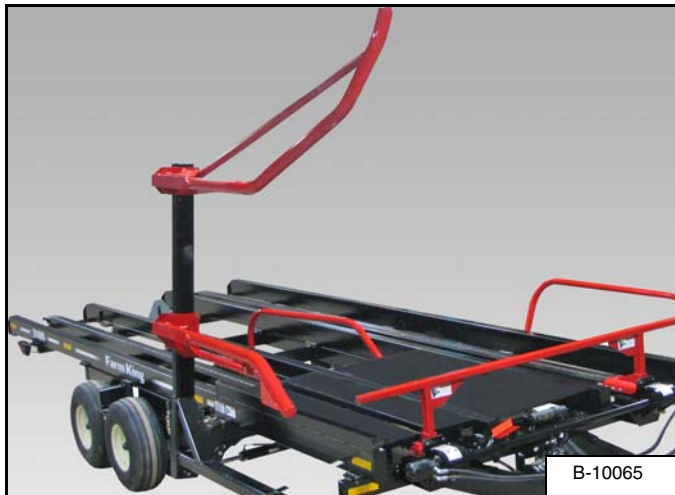

Fully raise the pick up arm [Figure 23].

**! IMPORTANT**

Depending on the diameter of the bale, adjust the inner fork so that the bale just clears the carrier when it is lifted.

**Figure 24**

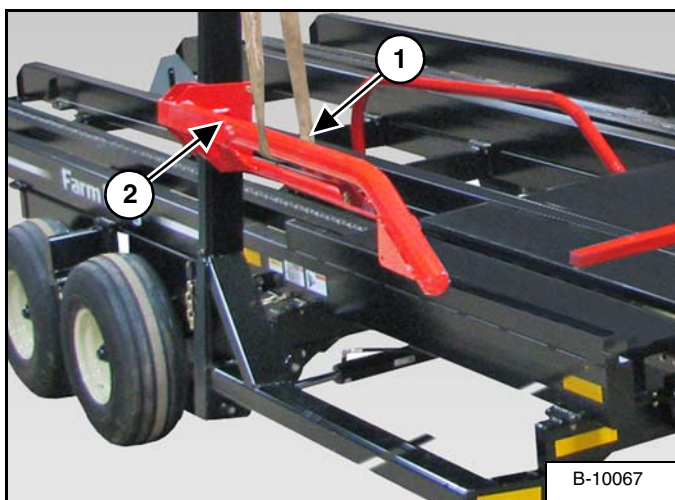

Install a strap (Item 1) around the inner fork arm (Item 2) [Figure 24]. Connect the strap to an approved lifting device.

Loosen the two 5/8" x 6" bolts (Item 3) [Figure 22].

Lower the inner fork arm to the desired height above the carrier deck.

Tighten the two 5/8" x 6" bolts to secure the inner fork arm to the pick up arm.

Remove lifting strap.

Fully lower the pick up arm.

**Figure 25**

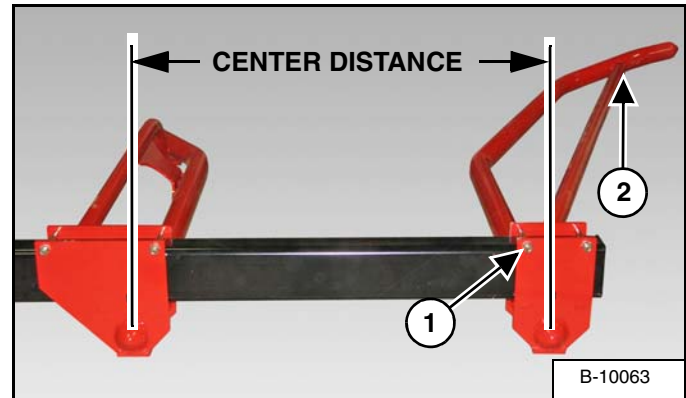

Loosen the two 5/8" x 6" bolts (Item 1) and move the RH fork with deflector (Item 2) [Figure 25] to the desired distance.

**Adjust the RH fork with deflector per bale sizes below:**

BALE DIAMETER	CENTER DISTANCE
72 in. (183 cm)	48 in. (122 cm)
60 in. (152 cm)	44 in. (112 cm)
48 in. (122 cm)	38 in. (97 cm)

Verify that all hardware / bolted connections on the pick up arm are torqued according to the specifications of the bolt chart. (See "HARDWARE TORQUE VALUES" on page 101.)

**First time operation:**

- Approach the bale and check bale diameter, to ensure the fork spacing is correct.
- Cycle the pick up arm slowly with a bale and inspect just before lifting bale from ground.
- Finish the cycle and observe how the bale transfers from the forks to the carrier beam. If transfer is smooth with minimum bale binding, assembly is completed. If not, adjust the forks to a different location and try until loading is smooth.



**OPERATION**

GENERAL INFORMATION .....35  
    Pre - Operation Checklist .....35  
    Break - In Checklist .....36  
    Tractor Requirements .....37  
    Entering And Leaving The Operator's Position .....37

INITIAL SET-UP .....38  
    Connecting The Bale Carrier To The Tractor .....38  
    Leveling The Bale Carrier .....40  
    Connecting Hydraulic Lines .....41  
    Connect Electrical Harness .....42  
    Control Handle Description .....42  
    Loading Procedure .....43  
    Optional Bale Stop .....45  
    Unloading Procedure .....46

TRANSPORTING .....47  
    Requirements .....47  
    Transport Position .....47

# Farm King



**GENERAL INFORMATION**

**Pre - Operation Checklist**

Before operating the Bale Carrier for the first time and each time thereafter, check the following items:



**MOVING PART HAZARD**

To prevent serious injury or death from moving parts:

- Close and secure guards and shields before starting.
- Keep hands, feet, hair and clothing away from moving parts.
- Disconnect and lockout power source before adjusting or servicing.
- Do not stand or climb on machine when operating.



**AVOID INJURY OR DEATH**

Wear safety glasses to prevent eye injury when any of the following conditions exist:

- When fluids are under pressure.
- Flying debris or loose material is present.
- Engine is running.
- Tools are being used.

1. Lubricate the equipment per the schedule outline in the Maintenance Section. (See “SERVICE SCHEDULE” on page 52.)
2. Check the Bale Carrier hitch for damaged, loose or missing parts. Repair as needed before operation.
3. Check that tire pressure is 90 psi (620 kpa).

4. Check that wheel bolt torque is 110 ft. lb. (149 Nm).
5. Fully clean the equipment. (See “CLEANING THE BALE CARRIER” on page 59.)
6. Check chain tension and adjust if necessary. (See “Adjusting Chain Tension” on page 56.)
7. Check carrier beams and add graphite coating if necessary. (See “Resurfacing” on page 59.)
8. Inspect all electrical connections to ensure proper function of the machine.
9. Inspect all safety reflective decals, slow moving vehicle decals and lights where applicable.

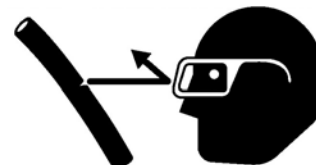

Leaking fluids under pressure can enter the skin and cause serious injury or death. Immediate medical attention is required. Wear goggles. Use cardboard to check for leaks.

10. Check condition of all hydraulic components for leaks. Repair as required.

**NOTE: Do not operate with hydraulic leaks.**

11. Verify that the lift arm transport lock has been removed and securely stored.
12. Verify that the bale carrier is properly connected to the tractor with the safety chain.

**Break - In Checklist**

Check the following mechanical items after 1 hour of operation and again after 10 hours of operation:

1. Check condition of all hydraulic components for leaks. Tighten fittings to correct leaks or replace components. Do not operate with hydraulic leaks.

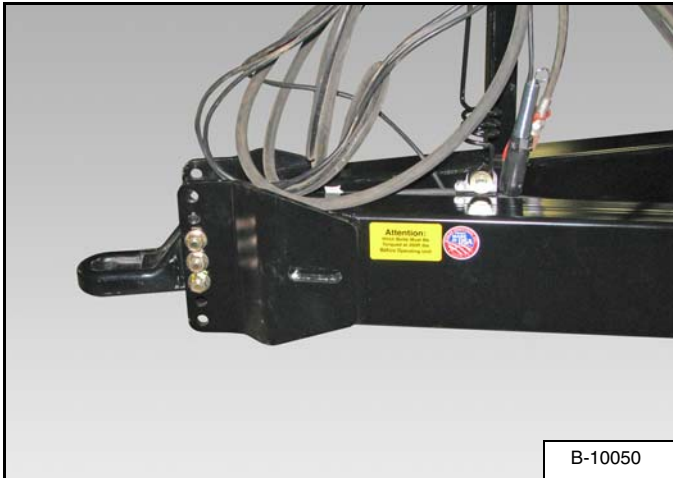
**Figure 26**

2. Check the bale carrier hitch for damaged, loose or missing parts **[Figure 26]**. Repair as needed before operation.
3. Check for loose fasteners and hardware. Tighten as required.
4. Check that tire pressure is 90 psi (620 kpa).
5. Check that wheel bolt torque is 90 ft. lb. (122 Nm).

Tractor Requirements



**AVOID SERIOUS INJURY OR DEATH**

The tractor must be equipped with an approved Roll Over Protection Structure (ROPS) and safety belts to help prevent personal injury or death caused by tractor roll over.



- Keep shields and all guards in place.
- Keep away from moving parts.
- Keep bystanders away.

The 2400 Round Bale Carrier will require a tractor with minimum 80 hp (60 kw) and two pair of remote outlets (operate with either closed center or open center / load sensing hydraulic system).



Towing Vehicle / Tractor must have adequate braking capacity to safely control 23,140 lb. (10,496 kg) GVW trailing load. Do not tow over 20 mph (32 km/h). Towing Vehicle / Tractor unit should weigh 15,500 lb. (7,030 kg) or approximately 67% of GVW.

Drawbar Adjustment

Figure 27

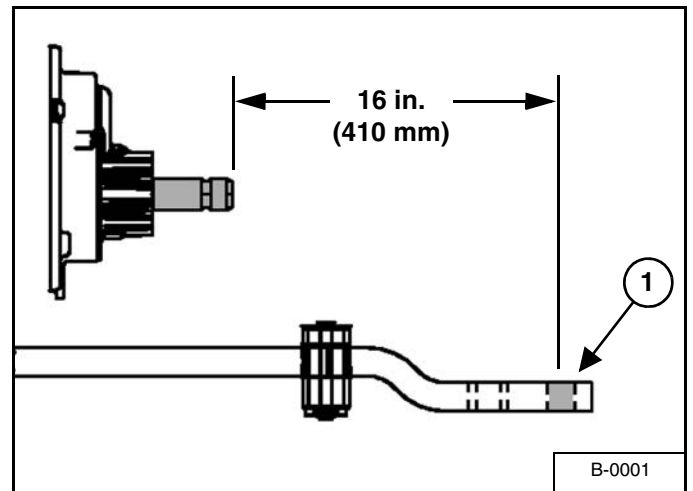

Adjust the tractor's drawbar in / out, until the center of the hitch pin hole (Item 1) [Figure 27] is 16 inches (410 mm) from the end of the tractor's PTO shaft. See your tractor's owner's manual for correct adjustment procedures.

Entering And Leaving The Operator's Position

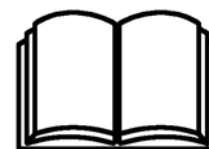

Follow the instructions in your tractor's operation manual for the correct procedure.

Entering The Operator's Position

Move to the operator's position, start the engine and release the parking brake.

*Leaving The Operator's Position*



**WARNING**

**AVOID INJURY OR DEATH**

**Before you leave the operator's position:**

- **Always park on a flat level surface.**
- **Place all controls in NEUTRAL.**
- **Engage the park brake.**
- **Stop the engine and remove the key.**
- **Wait for all moving parts to stop.**

Park the tractor / equipment on a flat level surface.

Place all controls in neutral, engage the park brake, stop the engine and wait for all moving parts to stop. Leave the operator's position.

**INITIAL SET-UP**

**Connecting The Bale Carrier To The Tractor**

Always inspect the tractor's drawbar and Bale Carrier hitch before connecting. See the tractor's owner's manual.

Verify that the tractor's drawbar is adjusted correctly for use with the Bale Carrier. (See "Drawbar Adjustment" on page 37.)

Enter the operator's position. (See "Entering The Operator's Position" on page 37.)

Move the tractor into position in front of the Bale Carrier.



**WARNING**



**AVOID INJURY OR DEATH**

**Before moving the tractor, look in all directions and make sure no bystanders, especially small children are in the work area. Do not allow anyone between the tractor and the equipment when backing up to the equipment for connecting.**

Move the tractor backwards, aligning the drawbar with the Bale Carrier hitch.

**NOTE: The jack may need to be lowered or raised for proper alignment of the drawbar and hitch.**

If the Bale Carrier hitch needs to be adjusted, stop the tractor when drawbar is just in front of the Bale Carrier hitch.

Leave the operator's position. (See "Leaving The Operator's Position" on page 38.)

**Figure 28**

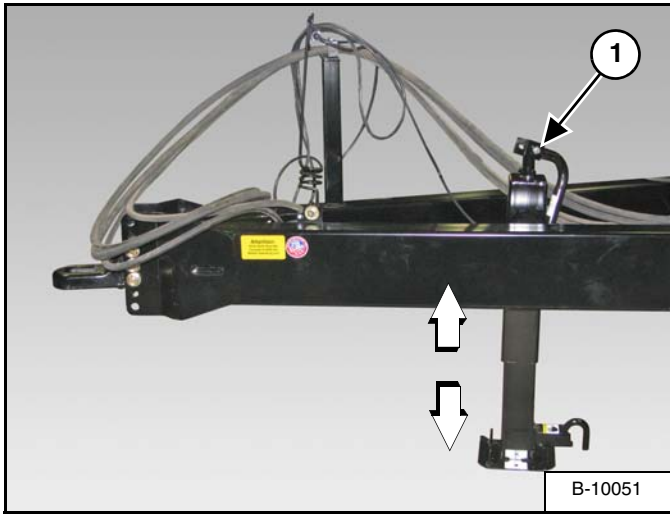

Turn the handle (Item 1) [Figure 28] clockwise to raise the hitch or counterclockwise to lower the hitch.

Lower or raise the Bale Carrier hitch until aligned with the tractor's drawbar.

Move to the operator's seat, start the engine and release the parking brake.

Move the tractor backwards, aligning the drawbar hitch pin hole with the Bale Carrier hitch pin hole(s).

Stop the tractor and leave operator's position.

**Figure 29**

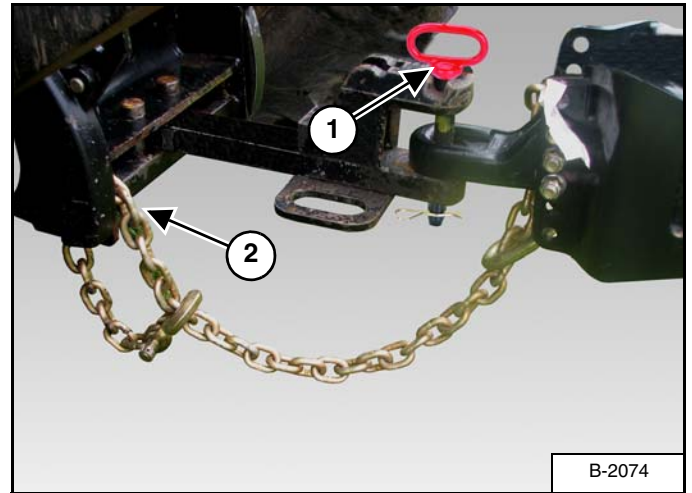

Install the hitch pin (Item 1) [Figure 29] and retaining pin to securely fasten the Bale Carrier hitch to the tractor drawbar.

Attach the safety chain (Item 2) [Figure 29] around the drawbar.



**AVOID INJURY OR DEATH**

Keep fingers and hands out of pinch points when connecting and disconnecting equipment.

**NOTE:** Always use a hitch pin of adequate size and strength and a retaining pin with a locking device.

Leveling The Bale Carrier

**! IMPORTANT**

The bale carrier frame must be adjusted down or up until the bale carrier is parallel with the ground prior to operation.

**! WARNING**

**AVOID INJURY OR DEATH**

Wear safety glasses to prevent eye injury when any of the following conditions exist:

- When fluids are under pressure.
- Flying debris or loose material is present.
- Engine is running.
- Tools are being used.

Figure 30

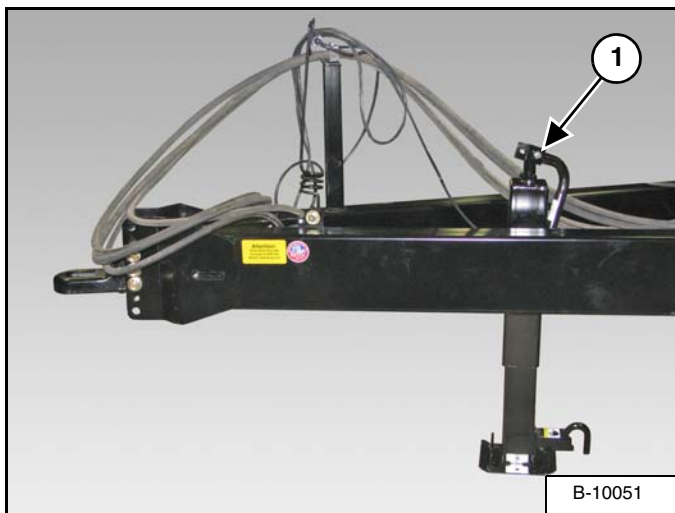

With the bale carrier attached to the tractor, lower the jack from the transport position. Using the handle (Item 1) [Figure 30] on the jack, raise the jack until the weight of the bale carrier is on the jack. This will allow the clevis mounting bolts to be loosened and moved for leveling (if required).

**! IMPORTANT**

Place one support stand under the two hitch beams, to evenly support the hitch beams. The two hitch beams pivot independent from each other. Hitch beam without jack will drop to the ground.

Figure 31

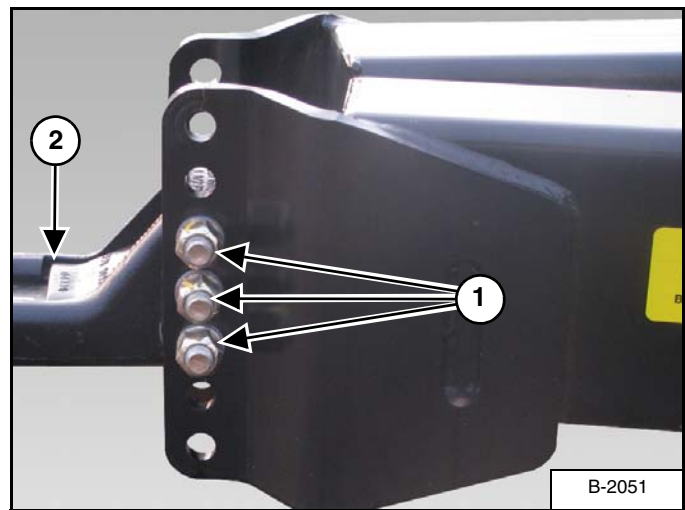

With the two hitch beams evenly supported, loosen the three clevis mounting bolts (Item 1) [Figure 31].

Raise or lower the jack until the bale carrier frame is parallel with the ground. Raise or lower the clevis (Item 2) [Figure 31] and align the closest clevis mounting holes with frame. Install the three bolts.

Tighten the three clevis mounting bolts to the correct torque and raise the jack into the storage position.

**! IMPORTANT**

The objective of adjusting the hitch height is to bring the tipping frame firmly on the ground when unloading, but not hard enough to transfer excessive machine weight onto the tipping frame.



**Connecting Hydraulic Lines**



**HIGH PRESSURE FLUID HAZARD**

To prevent serious injury or death from high pressure fluid:

- Relieve pressure on system before repairing or adjusting.
- Wear proper hand and eye protection when searching for leaks. Use wood or cardboard instead of hands.
- Keep all components in good repair.



- Contain and dispose of any oil leakage in an environmentally safe manner.
- Thoroughly clean the quick couplers before making connections. Dirt can quickly damage the system.

**NOTE:** Make sure the quick couplers are fully engaged. If the quick couplers do not fully engage, check to see that the couplers are the same size and type.

*To Connect:*

**Figure 32**

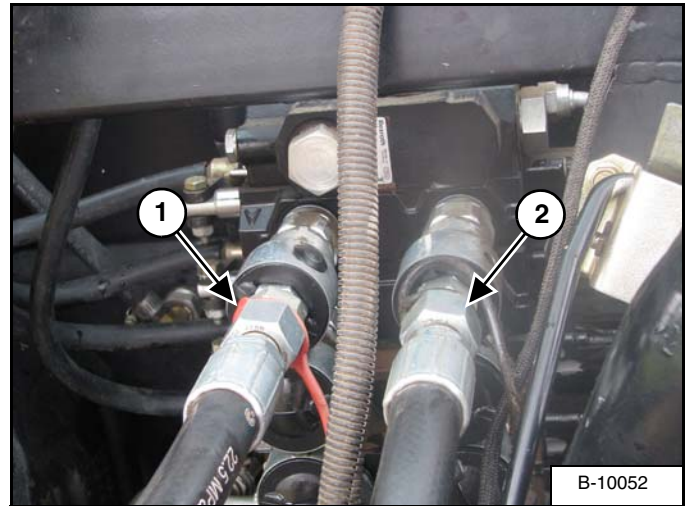

Connect the two hydraulic lines to the tractor [Figure 32].

1. Supply Line (Red dust cap) "P" port of valve bank.
2. Return Line (Black dust cap) "T" port of valve bank.

*To Disconnect:*



**AVOID BURNS**

Hydraulic fluid, tubes, fittings and quick couplers can get hot when running equipment. Be careful when connecting and disconnecting quick couplers.

Pull on the hydraulic lines to disconnect.

**Connect Electrical Harness**

**Figure 33**

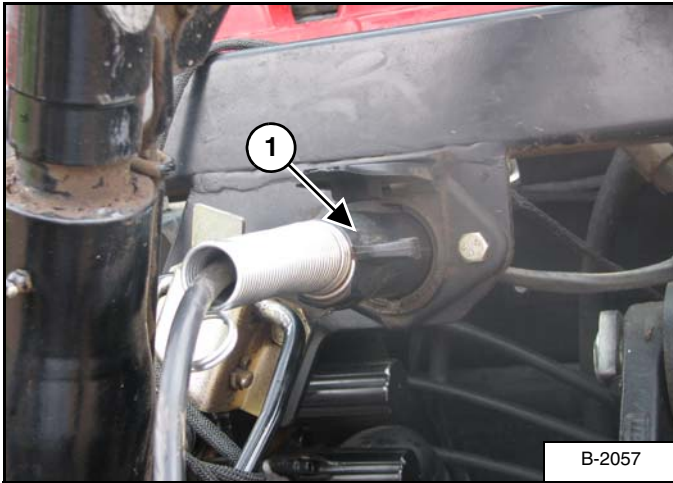

Connect the Bale Carrier's lighting harness (Item 1) [Figure 33] to the tractor's electrical system.

**Control Handle Description**

Engage tractor auxiliary hydraulics.

**Figure 34**

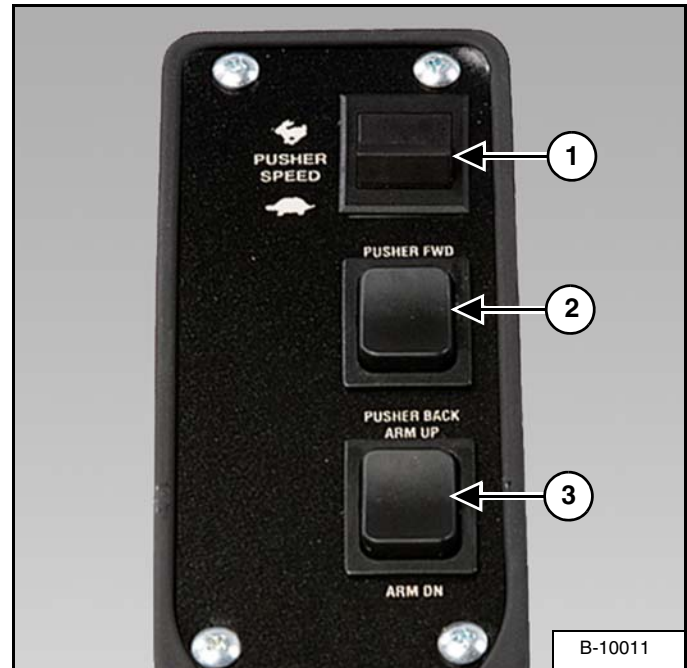

**1. PUSHER SPEED**

Press PUSHER SPEED switch UP (Rabbit) to operate pusher at a high speed. Press PUSHER SPEED switch DOWN (Turtle) to operate pusher at a low speed.

**NOTE: Torque is increased at low speed and pushes bales with more force.**

**2. PUSHER FWD / PUSHER BACK**

Press and hold the PUSHER FWD switch to move pusher forward. Press and hold the PUSHER BACK switch to move pusher back.

**3. ARM UP / ARM DN (Down)**

Press and hold the ARM UP switch to raise the lift arm. Press and hold the ARM DN switch to lower the lift arm.

**Loading Procedure**



**Before operating the equipment:**

- Clear the work area of all bystanders, especially small children.
- Clear the work area of all obstacles.
- Keep shields and all guards in place.
- Keep away from moving parts.



To avoid unbalanced loads, only push front bales back one bale length to prepare for the next bale.



When loading bales, maintain a minimum of 2 ft. (61 cm) between rear bales and rear of carrier deck. Rear bales must not extend beyond the carrier deck.

Move to the operator's position, start the engine and release the parking brake. (See "Entering The Operator's Position" on page 37.)

Move the tractor and bale carrier straight forward up to 5 mph (8 km/h), center the first bale in the bale forks.

*Empty / Full Indicator*

**Figure 35**

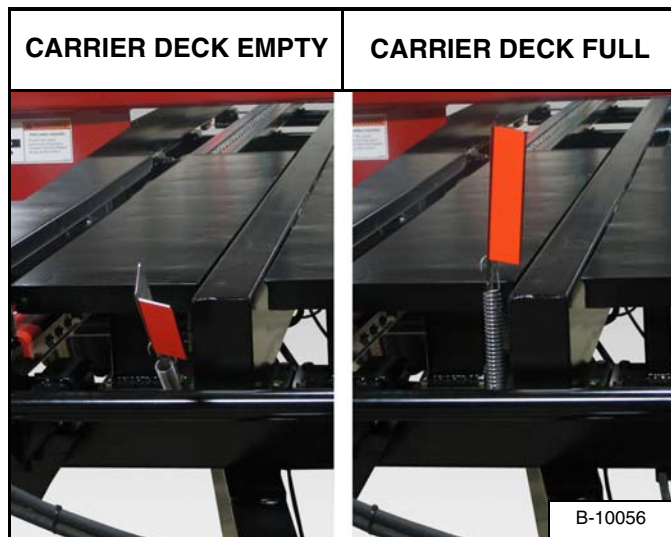

**Indicator Down** - Available deck space for additional bales or all bales have been removed (unloaded) from deck.



At the end of the unloading process, front indicator comes down (after pushing off the last bales) warning the operator to release pusher back button, then move forward, lower beam and bring the pusher home (fully forward).

**Indicator Up** - When the bale carrier reaches its capacity, bales will contact and move the rear indicator backward, pulling the cable raising the front indicator plate (upright) indicates not to load any more bales.

*End On Bale Pick-Up*

**! IMPORTANT**

**Always lower lift arm fully before operating the pusher.**

**! IMPORTANT**

**Always load two bales on the front before operating the pusher (pushing bales back).**

**Figure 36**

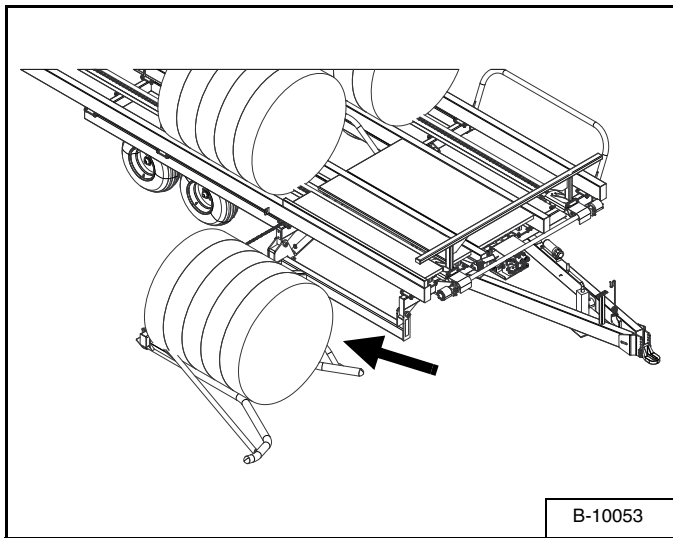

Move the tractor and bale carrier straight forward drive so the inner arm of the loading fork is against the inner edge of the bale. The bale will then be loaded onto the carrier in the same direction as it was picked up **[Figure 36]**.

Press and hold the ARM UP switch to raise the lift arm placing the bale onto the deck.

**NOTE:** The momentum of the lift arm makes the bale roll to the left side, contacting the bale retainer and then resting between the left inside and outside carrier beams. When the second bale is loaded, it will fall into place between the right inside and outside carrier beams.

Press and hold the ARM DN switch and fully lower the lift arm.

Move the tractor and bale carrier straight forward drive so the inner arm of the loading fork is against the inner edge of the next bale.

Then load the second bale onto the carrier in the same direction as it was picked up.

Press and hold the ARM DN switch and fully lower the lift arm.

Press and hold the PUSHER BACK switch to move pusher backward, moving the bales far enough to the rear to provide room to load the next two bales.

Press and hold the PUSHER FWD switch to move pusher all the way forward.

Repeat procedure until the desired number of bales have been loaded or the carrier deck is full (Indicator Raised).

Side On Bale Pick-Up



Contact the bale about 12 in. (30 cm) from its outer end when using the bale deflector. Contacting the bale further to the inside may result in damage to the deflector, bale lift arm or bale.

To pick up bales that are placed “Side On,” the deflector rotates the bale 90° before it is lifted up onto the carrier deck. Forward travel is used to rotate the bale. Approach the bale so that the outer end of the bale rides up on the bale deflector as the loading arm moves under the bale.

Figure 37

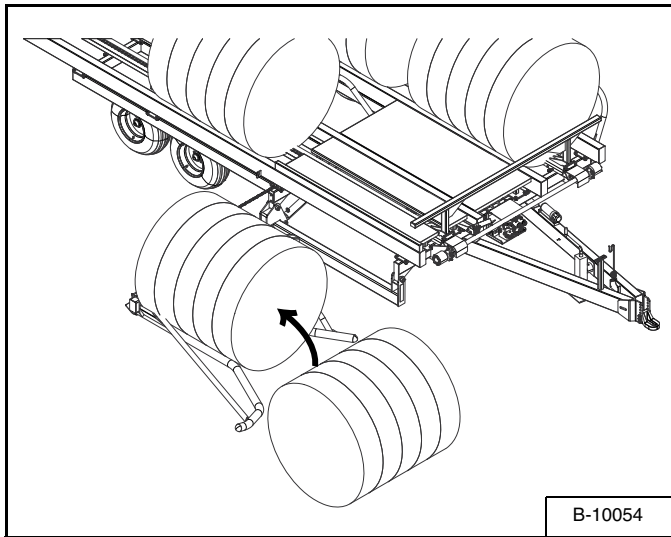

Move the tractor and bale carrier straight forward, contact the first bale (Side-On) about 12 inches (30 cm) from the outer end when using the bale deflector. [Figure 37].

Press and hold the ARM UP switch to raise the lift arm placing the bale onto the deck.

**NOTE: The momentum of the lift arm makes the bale roll to the left side, contacting the bale retainer and then resting between the left inside and outside carrier beams. When the second bale is loaded, it will fall into place between the right inside and outside carrier beams.**

Press and hold the ARM DN switch and fully lower the lift arm.

Move the tractor and bale carrier straight forward until the deflector contacts the second bale (Side-On) about 12 inches (30 cm) from the outer end (rotating bale 90°.

Then load the second bale onto the carrier in the same direction as it was picked up.

Press and hold the ARM DN switch and fully lower the lift arm.

Press and hold the PUSHER BACK switch to move pusher backward, moving the bales far enough to the rear to provide room to load the next two bales.

Press and hold the PUSHER FWD switch to move pusher all the way forward.

Repeat procedure until the desired number of bales have been loaded or the carrier deck is full (Indicator Raised).

Optional Bale Stop

Figure 38

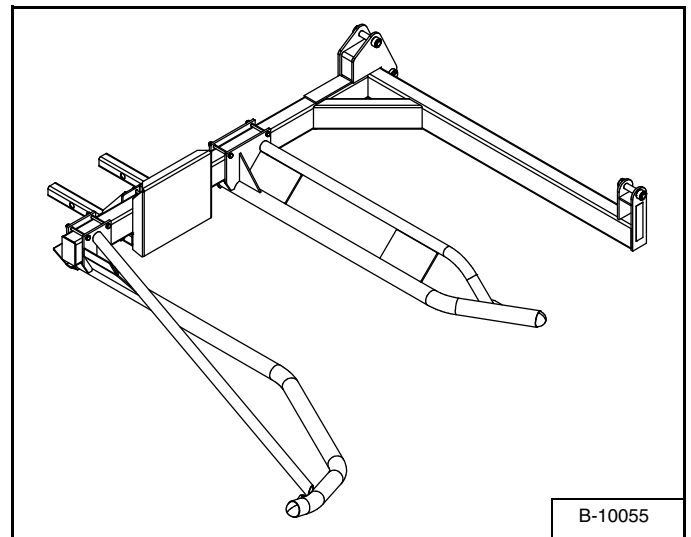

An adjustable bale stop [Figure 38] is available, when picking up / loading narrower 48 inch (122 cm) bales.

Using this adjustable bale stop permits loading bales closer to the front of the bale carrier so a full complement of ten (10) bales can be loaded. 48 inch (122 cm) bales only.

**NOTE: The adjustable bale stop is bolted to the lift arm with supplied U-bolts and can be adjusted to the desired position.**

**Unloading Procedure**



**ELECTROCUTION HAZARD**

To prevent serious injury or death from electrocution, stay at least 50 ft. (15 m) away from overhead power line when raising tipping frame or lift arm.

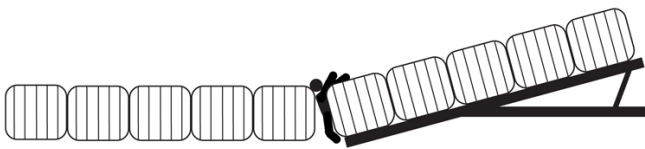

**AVOID INJURY OR DEATH**

Before moving the tractor and bale carrier, look in all directions and, make sure no bystanders, especially small children are in the work area. Do not allow anyone between the tractor and the equipment when unloading bales.

Move the tractor and bale carrier to unloading area.

Stop the tractor and bale carrier on flat level surface.

**Figure 39**

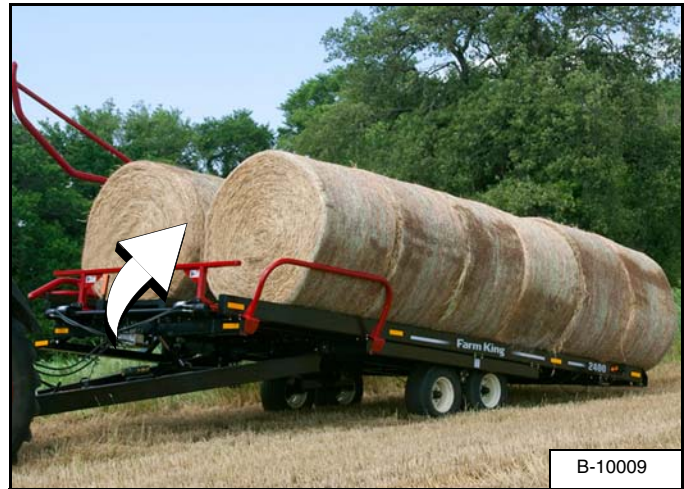

Using the tractor auxiliary hydraulics, raise the tipping frame until the frame is slightly off the ground [Figure 39].

Press and hold the PUSHER BACK switch, once the rear bales have been pushed off, slowly drive forward while pushing the bales back (unloading) to keep all bale ends in contact. When the last bales have been unloaded and indicator lowers, release PUSHER BACK switch.



Do not run pusher all the way to the end, the resulting shock load may cause damage to chain and drive.



Front indicator comes down (after pushing off the last bales) signaling the operator to release pusher back switch.

Drive the tractor forward until there is enough room to safely lower the TIPPING FRAME.

Using the tractor auxiliary hydraulics, fully lower the tipping frame.

**TRANSPORTING**

**Requirements**

Comply with federal, state, local and provincial laws regarding the transport of farm equipment on public roadways.



**AVOID SERIOUS INJURY OR DEATH**

Use of an unapproved hitch or tractor / tow vehicle can result in loss of control, leading to serious injury or death.

Tractor / tow vehicle and hitch must have the rated capacity to tow equipment.



**AVOID SERIOUS INJURY OR DEATH**

Excess weight will greatly increase tractor stopping distance and may cause the operator to lose control of the tractor or tow vehicle.



Towing Vehicle / Tractor must have adequate braking capacity to safely control 23,140 lb. (10,496 kg) GVW trailing load. Do not tow over 20 mph (32 km/h). Towing Vehicle / Tractor unit should weigh 15,500 lb. (7,030 kg) or approximately 67% of GVW.

Verify that the tractor / tow vehicle is approved for transporting the equipment and that the equipment is securely attached to the tractor / tow vehicle.

Verify safety chain is installed and properly connected before transporting equipment.

Verify that the SMV (Slow Moving Vehicle) emblem, all lights and reflectors are clean and visible.



Do not transport if rear bales are overhanging rear of carrier deck. Rear of carrier deck should extend beyond rear bales for a minimum of 2 ft. (61 cm).

**Transport Position**

Fully raise lift arm, engage and secure lock chains.

**Figure 40**

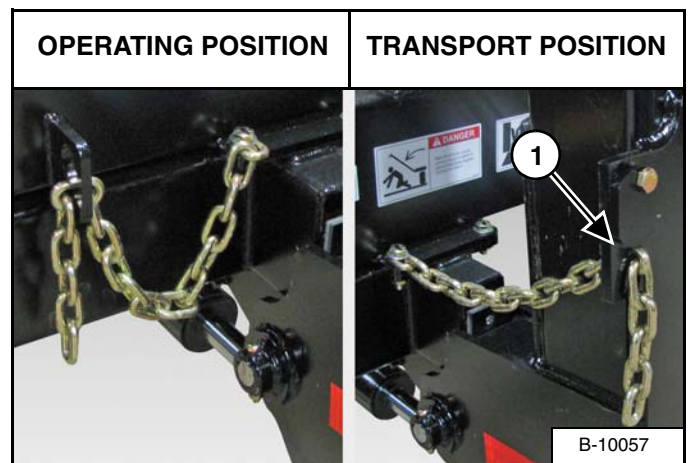

Install / secure the lock chain (Item 1) [Figure 40] to the pick-up arm.



Travel at a low speed when transporting over bumps / rough terrain and monitor the condition and position of bales while transporting.

# Farm King





**MAINTENANCE**

TRUBLESHOOTING .....	51
General Chart .....	51
SERVICE SCHEDULE .....	52
Maintenance Intervals .....	52
LUBRICATION .....	53
Recommendations .....	53
Locations .....	53
PUSHER CHAIN AND SPROCKET .....	55
Inspection .....	55
Adjusting Chain Tension .....	56
Shortening The Pusher Chain .....	57
AXLE .....	58
Wheel Bolts Torque .....	58
Tire / Wheel Replacement .....	58
Wheel Bearings .....	58
Tire Pressure .....	58
CLEANING THE BALE CARRIER .....	59
CARRIER BEAMS .....	59
Resurfacing .....	59
SAFETY SIGN (DECAL) INSTALLATION .....	59
Procedure .....	59
STORAGE AND RETURN TO SERVICE .....	60
Storage .....	60
Return To Service .....	60
BALE STORAGE .....	60

# Farm King



**TROUBLESHOOTING**

**General Chart**



Instructions are necessary before operating or servicing equipment. Read and understand the Operator And Parts Manual and safety signs (decals) on equipment. Follow warnings and instructions in the manuals when making repairs, adjustments or servicing. Check for correct function after adjustments, repairs or service. Untrained operators and failure to follow instructions can cause injury or death.

**NOTE:** If a problem is encountered that is difficult to solve, even after having read through this troubleshooting section, please call your local distributor or dealer. Before you call, please have this Operator And Parts Manual and the serial number of your machine at hand.

PROBLEM	CAUSE	CORRECTION
No functions operating.	No hydraulic flow to control valve.	Make sure there is hydraulic flow going to carrier's valve bank. Supply line is on the top side (Red dust cap) and Return line is bottom line (Black dust cap).
	Valve bank is not correctly configured to match tractor hydraulic system.	Make sure valve bank is correctly configured to match tractor hydraulic system type, OPEN-CENTER or CLOSE-CENTER.  NOTE: Select OPEN CENTER with tractors having LOAD SENSING hydraulic systems. See the tractor's manual for hydraulic system type.
	No electric power.	Check electrical harness connection. Check control handle fuse.
Bale Carrier freezes, creates back pressure on hydraulic hose.	Hydraulic couplers are not the same size and type as the tractor.	Make sure the female and male couplers on the bale carrier are compatible with the tractor.

**SERVICE SCHEDULE**

**Maintenance Intervals**

Maintenance work must be done at regular intervals. Failure to do so will result in excessive wear and early failures. The service schedule is a guide for correct maintenance of the 2400 Round Bale Carrier.



Instructions are necessary before operating or servicing equipment. Read and understand the Operator and Parts Manual and safety signs (decals) on equipment. Follow warnings and instructions in the manuals when making repairs, adjustments or servicing. Check for correct function after adjustments, repairs or service. Untrained operators and failure to follow instructions can cause injury or death.

#	DESCRIPTION	SERVICE PROCEDURES						
		Check	Clean	Lube	Change	Adjust	Drain	Locations
<b>Daily Maintenance (or every 8 hours)</b>								
1	Tire Pressure	•						
2	Wheel Bolts	•						
3	Axle Bearing			•				
4	Hydraulic Cylinders	•		•				
5	Pick-Up Arm			•				
6	Tipping Frame			•				
<b>Weekly (or every 50 hours)</b>								
7	Carrier Beams	•						
8	Pusher Chain And Sprocket	•		•				
9	Hydraulic Cylinders	•						
10	Bale Carrier	•	•					
<b>Annually (or every 500 hours)</b>								
11	Wheel Bearings	•		•				

**LUBRICATION**

**Recommendations**

Always use a good quality multi-purpose / lithium base grease when lubricating the equipment.



**Do not over-grease bearings. Greasing too often can damage seals and lead to premature bearing failure.**

- Always use a hand-held grease gun.
- Clean fitting before greasing, to avoid injecting dirt and grit.
- Replace and repair broken fittings immediately.
- If fittings will not take grease, remove and clean thoroughly. Replace fitting if necessary.

**Locations**



**Fluid such as engine oil, hydraulic fluid, coolants, grease, etc. must be disposed of in an environmentally safe manner. Some regulations require that certain spills and leaks on the ground must be cleaned in a specific manner. See local, state and federal regulations for the correct disposal.**

Lubricate the following grease locations EVERY 8 HOURS:

**Figure 41**

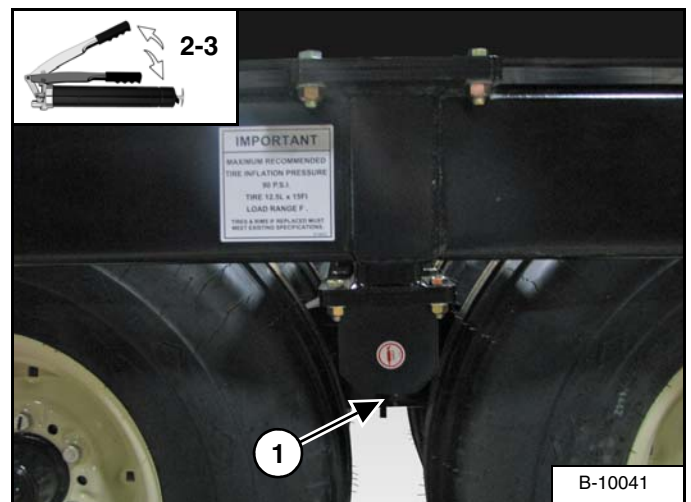

Apply two - three pumps of grease to all locations of the axle pivots (Item 1) [Figure 41].

Figure 42

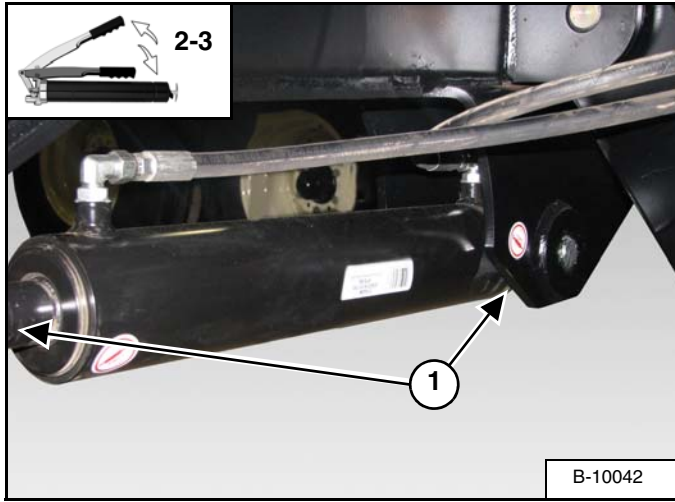

Apply two - three pumps of grease to both ends of the bale lift arm cylinder (Item 1) [Figure 42].

Figure 44

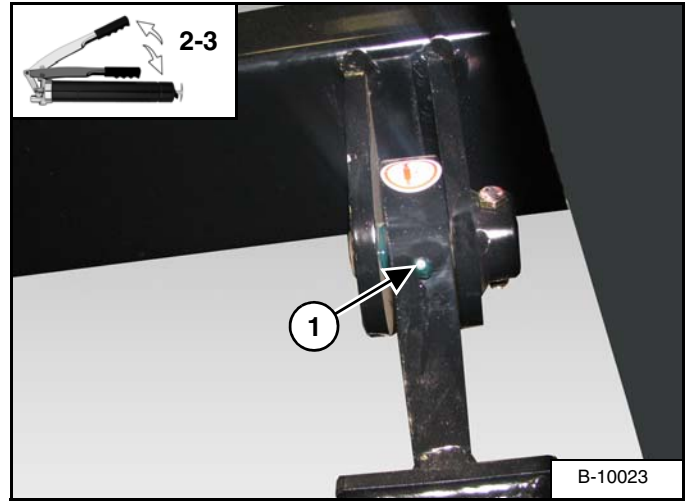

Apply two - three pumps of grease to the LH & RH hitch pivot bushings (Item 1) [Figure 44].

Figure 43

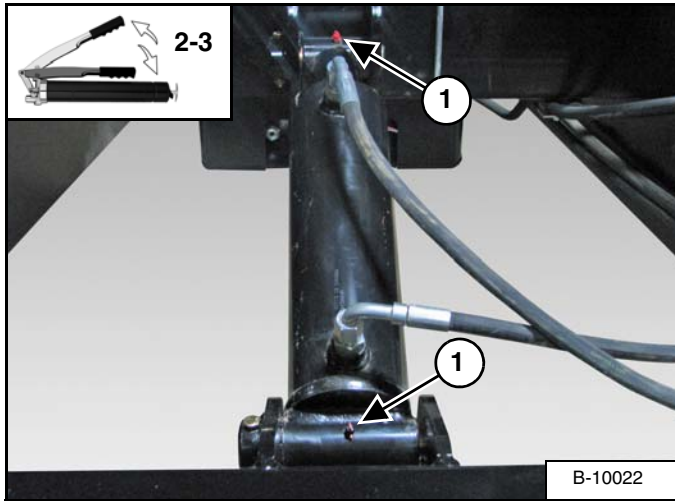

Apply two - three pumps of grease to both ends of the tipping frame cylinder (Item 1) [Figure 43].

Figure 45

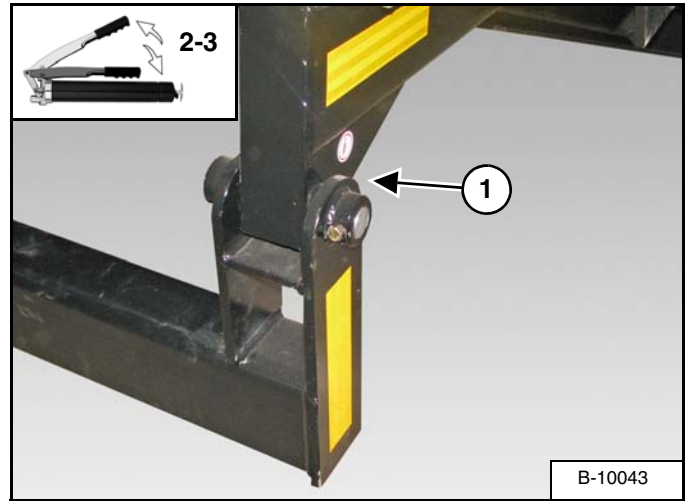

Apply two - three pumps of grease to the bale lift arm pivot bushings (Item 1) [Figure 45] (both sides).

Lubricate the following grease locations EVERY 50 HOURS:

**Figure 46**

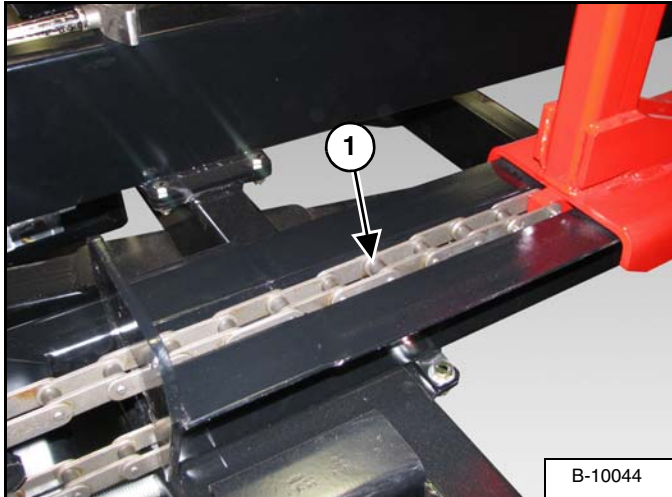

Using a brush, apply a SAE light machine oil (or equivalent) to pusher chain (Item 1) [Figure 46] several times during the season and before storing for an extended period of time.

**PUSHER CHAIN AND SPROCKET**

**Inspection**



**AVOID INJURY OR DEATH**

**Before you leave the operator’s position:**

- Always park on a flat level surface.
- Place all controls in NEUTRAL.
- Engage the park brake.
- Stop the engine and remove the key.
- Wait for all moving parts to stop.

Inspect and tighten chain and sprockets after the first 10 hours of operation and every 50 hours thereafter.

- Tightening adjustment bolts (clockwise) increases tension and loosening adjustment bolts (counter clockwise) reduces pusher chain tension.
- Both adjustment bolts should be tightened equally.
- Proper pusher chain tension may be verified by raising the chain by hand.
- Verify that there is even tension on both pusher chains.

Adjusting Chain Tension



**AVOID INJURY OR DEATH**

Before you leave the operator's position:

- Always park on a flat level surface.
- Place all controls in NEUTRAL.
- Engage the park brake.
- Stop the engine and remove the key.
- Wait for all moving parts to stop.

Figure 47



Pusher chain adjustment bolt is located behind shield (Item 1) [Figure 47].

Figure 48

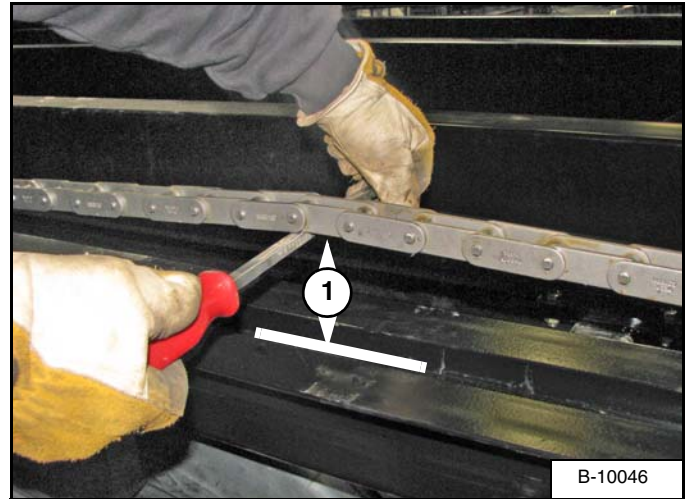

Lift up on the center of the pusher chain. There should be approximately four inches of upward slack (Item 1) [Figure 48]. If there is more than four inches of slack, adjust tension as needed. (See "Adjusting Chain Tension" on page 56.)

Figure 49

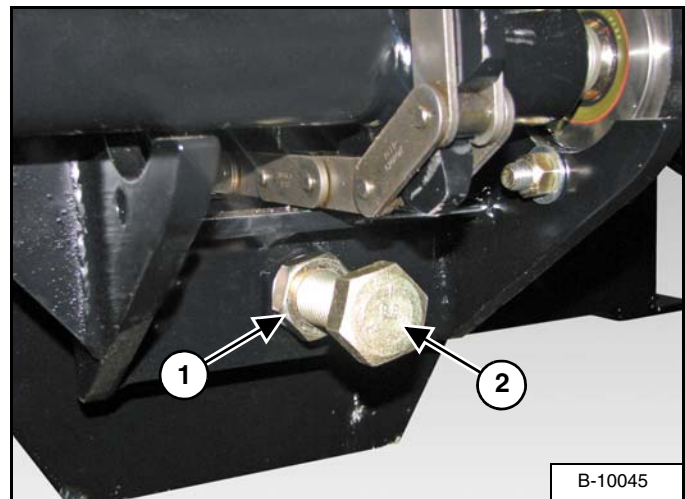

Loosen the jam nut (Item 1) [Figure 49].

Tighten the adjustment bolt (Item 2) [Figure 49] (clockwise) until there is approximately four inches of upward slack in the center of the chain. Tighten jam nut.

**NOTE:** If no more adjustment is possible, shorten pusher chain by removing one link. (See "Shortening The Pusher Chain" on page 57.)



Shortening The Pusher Chain



**AVOID INJURY OR DEATH**

Before you leave the operator's position:

- Always park on a flat level surface.
- Place all controls in NEUTRAL.
- Engage the park brake.
- Stop the engine and remove the key.
- Wait for all moving parts to stop.

Figure 50

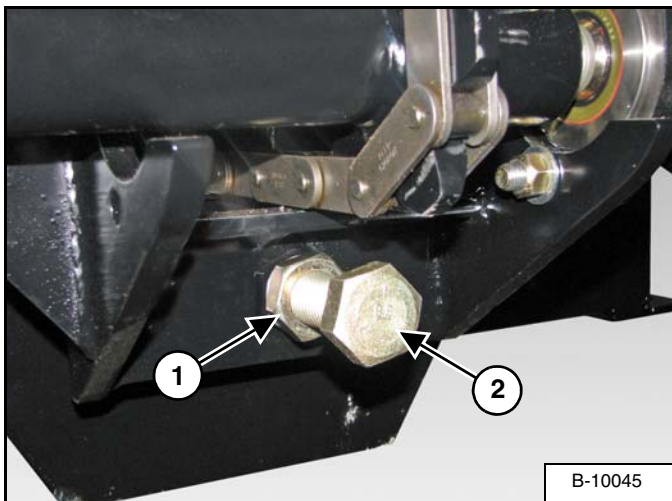

Loosen the jam nut (Item 1) [Figure 50].

Loosen the adjustment bolt (Item 2) [Figure 50] until there is enough slack in the pusher chain to remove one link.

Figure 51

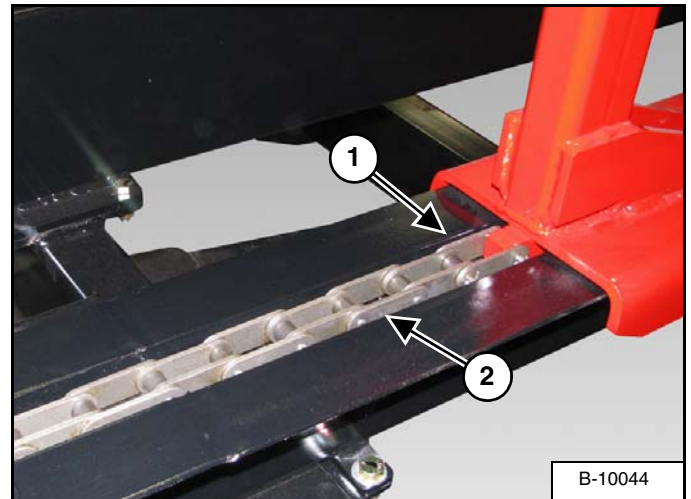

Remove connecting link (Item 1) then remove first chain link (Item 2) [Figure 51] behind the connecting link.

Re-install connecting link and adjust pusher chain until there is approximately four inches of upward slack.

Tighten jam nut.

Repeat procedure for second pusher chain.

Move to the operator's position, start the engine and engage tractor's auxiliary hydraulics.

Operate the pusher.

Figure 52

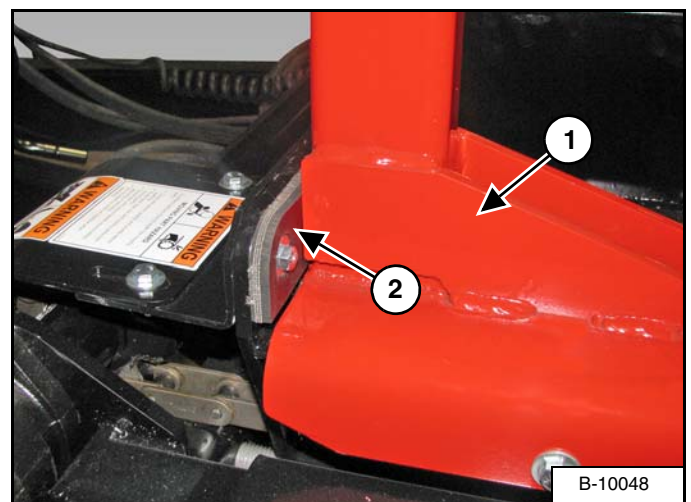

When pusher (Item 1) is returned forward, verify that both sides of the pusher contact the stops (Item 2) [Figure 52]. Adjust as needed until pusher contacts stops evenly.

**AXLE**

**Wheel Bolts Torque**

Check the torque on wheel bolts daily. Tighten wheel bolts to 110 lb. / ft. (149 N•m) torque.

**Tire / Wheel Replacement**

Empty the Bale Carrier (if required).



**AVOID INJURY OR DEATH**

Before you leave the operator's position:

- Always park on a flat level surface.
- Place all controls in **NEUTRAL**.
- Engage the park brake.
- Stop the engine and remove the key.
- Wait for all moving parts to stop.

Park the tractor / equipment on a flat level surface.

Place all controls in neutral, engage the park brake, stop the engine and wait for all moving parts to stop. Leave the operator's position.



**AVOID INJURY OR DEATH**

- The parking brake must be engaged before leaving the operator's position. Rollaway can occur because the transmission may not prevent machine movement.
- Always chock tires before performing any maintenance or service.

Place chock blocks behind and in front of the opposite tire to be removed.

Place a jack under the axle frame as close to the tire / wheel being replaced. Raise the jack until the tire / wheel is slightly off the ground.

**NOTE: Place blocks under the frame to help secure the carrier when tire / wheel is raised off the ground.**

Remove the six wheel bolts and remove the tire / wheel.

**Figure 53**

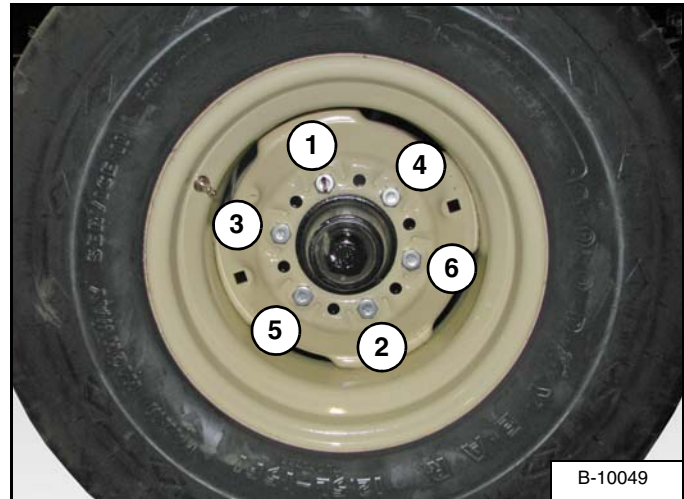

Install the new tire with the valve stem facing out.

Install the six wheel bolts (Items 1 - 6) [Figure 53].

Tighten wheel bolts in a criss-cross pattern [Figure 53]. Tighten wheel bolts to 110 lb. / ft. (149 N•m) of torque.

**Wheel Bearings**

Inspect and re-pack the wheel bearings annually with a quality SAE multi purpose type grease.

**NOTE: Grease every 500 hours if hub is equipped with grease fitting.**

**Tire Pressure**



**When inflating tires, use a clip-on chuck and extension hose long enough to allow you to stand to one side and NOT in front of or over the tire assembly.**

Check tire pressure daily. Fill tires to 90 psi (620 kPa).

**CLEANING THE BALE CARRIER**

Fully Clean the Bale Carrier EVERY 50 HOURS:

Keep the bale carrier free of any hay or straw build up, especially keep all electrical and hydraulic components clear.

**CARRIER BEAMS**

**Resurfacing**

Apply EZ-Slide (graphite-based coating to reduce sliding friction) to the carrier regularly, especially when handling heavier bales.



**Follow application instructions as provided by the coating manufacturer.**

**NOTE: At the end of the season a coating may be applied to prevent rust on the carrier beams.**

**SAFETY SIGN (DECAL) INSTALLATION**

**Procedure**



**When replacing safety signs (decals), the temperature must be above 10° C (50° F).**

- Remove all portions of the damaged safety sign (decal).
- Thoroughly clean the area with glass cleaner. Remove all adhesive residue.
- Allow the area to dry completely before installing the new safety sign (decal).
- Position the safety sign (decal) in the correct location. Remove a small portion of the backing paper on the safety sign (decal).
- Press on the safety sign (decal) where the backing paper has been removed.
- Slowly remove the remaining backing paper, pressing on the safety sign (decal) as the backing paper is removed.
- Using the backing paper, pressing firmly, move the backing paper over the entire safety sign (decal) area.

**NOTE: Small air pockets can be pierced with a pin and smoothed out using the piece of the backing paper.**

## STORAGE AND RETURN TO SERVICE

### Storage

Sometimes it may be necessary to store your Farm King Bale Carrier for an extended period of time. Below is a list of items to perform before storage.

## ! IMPORTANT

**DO NOT permit children to play on or around the stored machine.**

- Thoroughly clean the equipment.
- Lubricate the equipment.
- Inspect the hitch and all welds on the equipment for wear and damage.
- Check for loose hardware, missing guards, or damaged parts.
- Check for damaged or missing safety signs (decals). Replace if necessary.
- Replace worn or damaged parts.
- Touch up all paint nicks and scratches to prevent rusting.
- Clean pusher chain and brush with SAE light machine oil (or equivalent) to prevent rust.
- Repaint the top of the carrier beams with graphite paint such as EZ-Slide to prevent rust.
- Store the bale carrier in a clean, dry, sheltered area.
- Place the equipment flat on the ground.

### Return To Service

After the Farm King Bale Carrier has been in storage, it is necessary to follow a list of items to return the equipment to service.

- Be sure all shields and guards are in place.
- Lubricate the equipment.
- Clean and inspect pusher chain for excessive wear or stiffness. Check for proper adjustment and alignment.
- Inspect and repack wheel bearings with a SAE multi purpose type grease.
- Check that tires are properly inflated.
- Connect to a tractor and operate equipment, verify all functions operate correctly.
- Check for leaks. Repair as needed.
- Review the Operator's Manual.

### BALE STORAGE

## ! WARNING

**Take all necessary steps to prevent children or unauthorized personnel from entering storage area. Keep a fire extinguisher handy because of the flammable nature of the baled material.**

## ! CAUTION

**Use caution when retrieving bales. Do not extend bale-lifting equipment beyond its capacity or move more bales than the equipment is designed for.**

Stacks should be placed in an open, flat and well-drained area. The area should have safe and easy access for bale handling and transportation equipment.

**PARTS IDENTIFICATION**

GENERAL INFORMATION .....63

BASE FRAME .....63

    Carrier Hydraulic Assembly .....63

    Valve Bank Assembly .....64

    High Pressure Line Assembly .....67

    Hydraulic Return Line Assembly .....67

    Tilt Cylinder Extend Hydraulic Hose Assembly .....68

    Tilt Cylinder Retract Hydraulic Hose Assembly .....68

    Lift Arm Cylinder Assembly .....69

    Tilt Cylinder Assembly .....69

    Pusher Motor Assembly .....70

    Hydraulic Assembly Hardware .....71

    Frame Assembly (Top View) .....72

    Frame Assembly (Bottom View) .....74

    Carrier Frame Assembly .....76

    Electrical Assembly .....78

    Electrical Schematic (Prior to S/N BM240013000061) .....80

    Electrical Schematic (2018 and Later) .....81

    Control Handle Assembly .....82

    Tire Assembly .....83

    Tandem Axle Assembly W / Two Hubs .....84

    Tandem Axle Assembly W / Four Hubs .....85

    Hub Assembly .....86

    Pusher Assembly .....87

    Roller / Chain Guide Assembly .....88

    Pick Up Arm W / Deflector Assembly .....89

    Hitch Assembly .....90

    Optional Adjustable Bale Stop Assembly .....91

    Standard Hitch Assembly .....92

    Optional Clevis Hitch Assembly .....93

# Farm King



**GENERAL INFORMATION**

The parts identification section lists descriptions, part numbers and quantities for the Round Bale Carrier 2400. Contact your Farm King dealer for additional Round Bale Carrier 2400 parts information.

**BASE FRAME**

**Carrier Hydraulic Assembly**

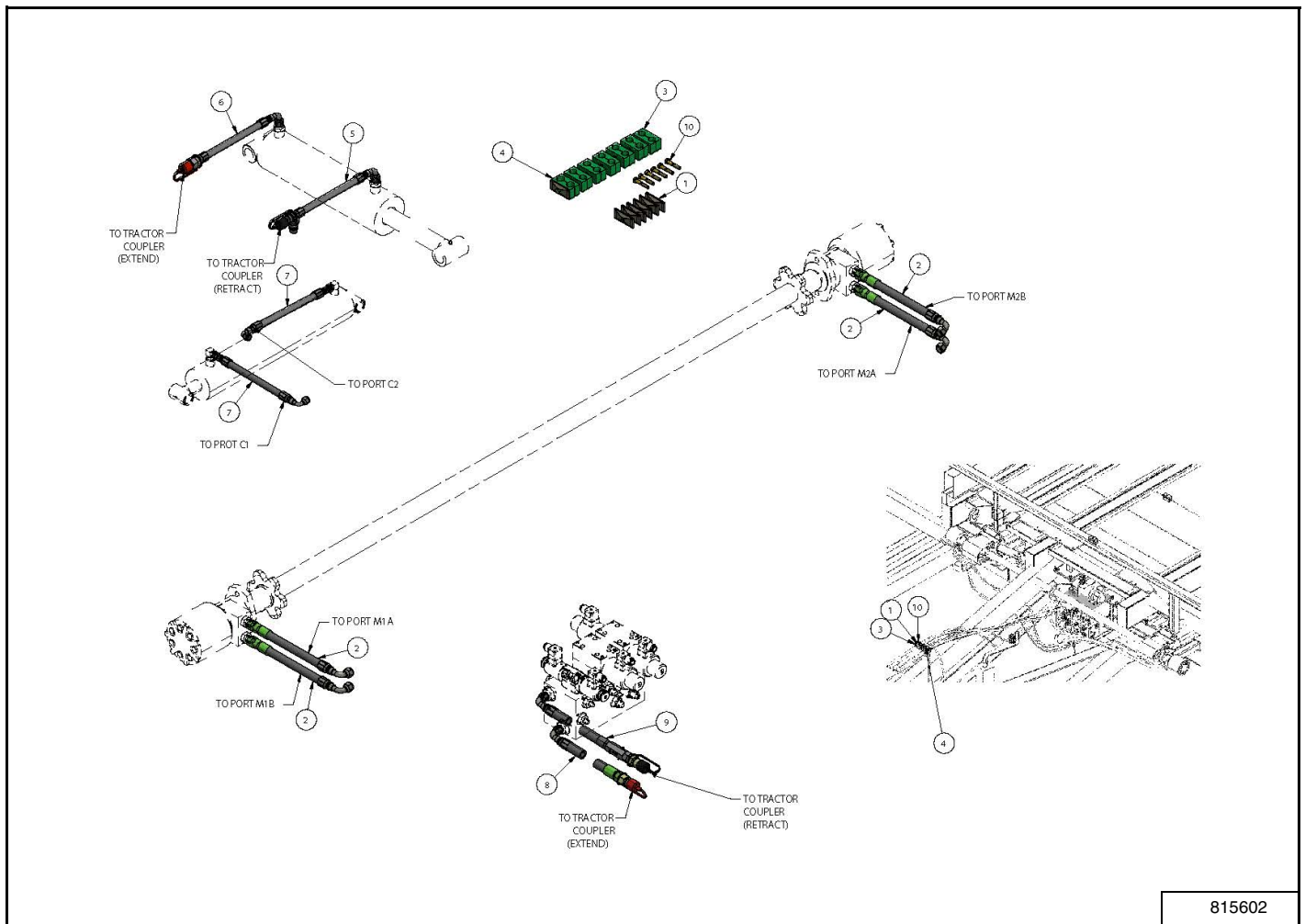

ITEM	PART NUMBER	DESCRIPTION	QTY
1	29256	COVER PLATE	6
2	815605	HOSE 1/2 X 60 3/4SWFJIC	4
3	815608	BLOCK POLYPROPELENE 3/8 PAIR	6
4	815610	1/2" HOSE LINE MOUNT ASSEMBLY	1
5	815612	HYD HOSE ASM/ TILT CYL	1
6	815614	HYD HOSE ASM/ TILT CYL	1
7	815616	HOSE 3/8 X 117 9/16SWFJIC X 9/16SWFJIC90	2
8	815822	HYD ASSY 1/2 X 142 PRESS LINE	1
9	815823	HYD LINE 1/2in 142 RETURN LINE ASSY	1
10	81925	HEX BOLT 5/16" X 1 3/4" (PL)	6

**Valve Bank Assembly**

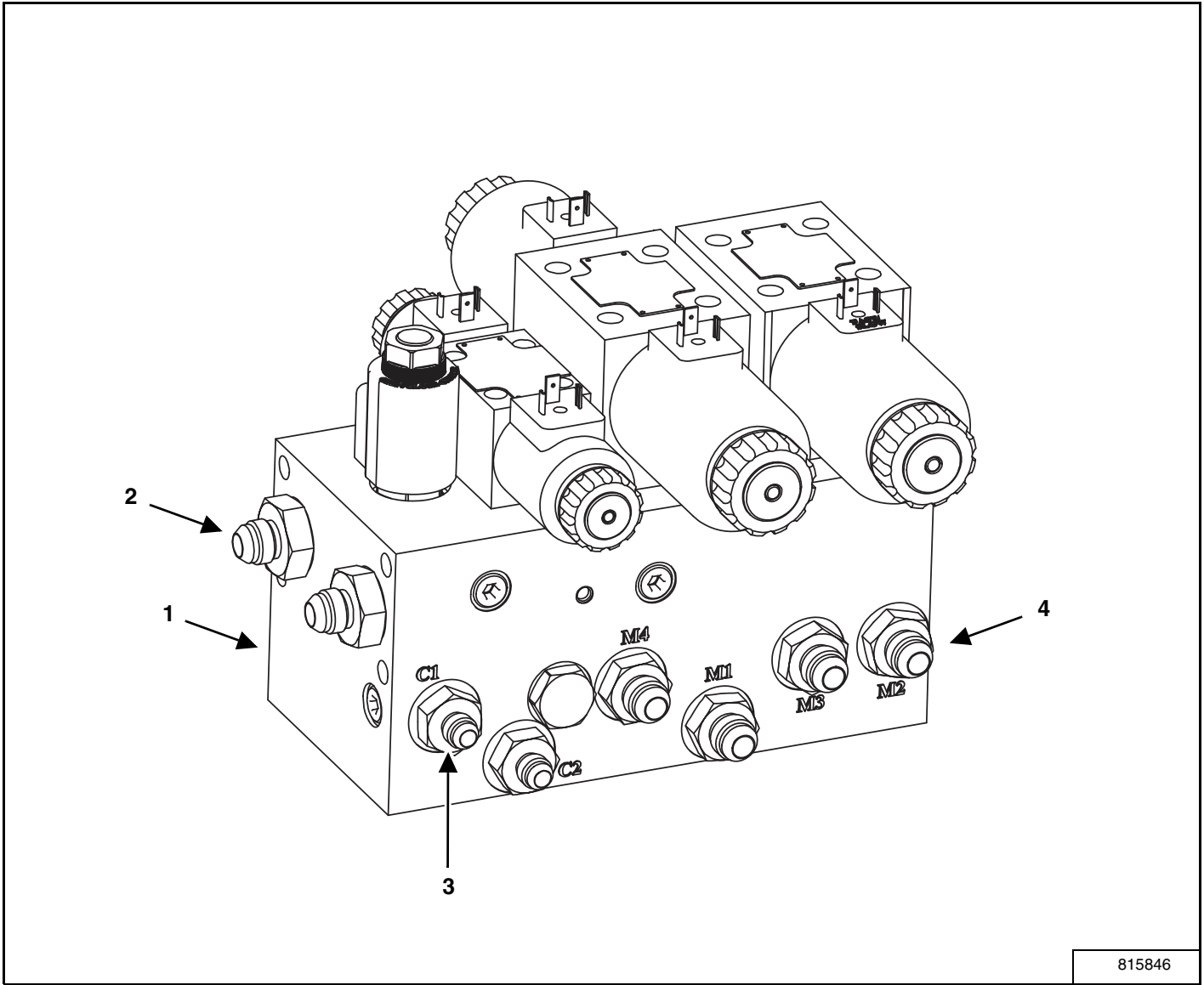

ITEM	PART NUMBER	DESCRIPTION	QTY
1	815296	VALVE MANIFOLD	1
2	83000074	STRAIGHT ADAPTER, 3/4" MJIC x 1-1/16" MORB	2
3	83000073	STRAIGHT ADAPTER, 9/16" MJIC x 7/8" MORB	2
4	886897	STRAIGHT ADAPTER, 7/8" MORB x 3/4" MJIC	4



**Manifold Service Parts**

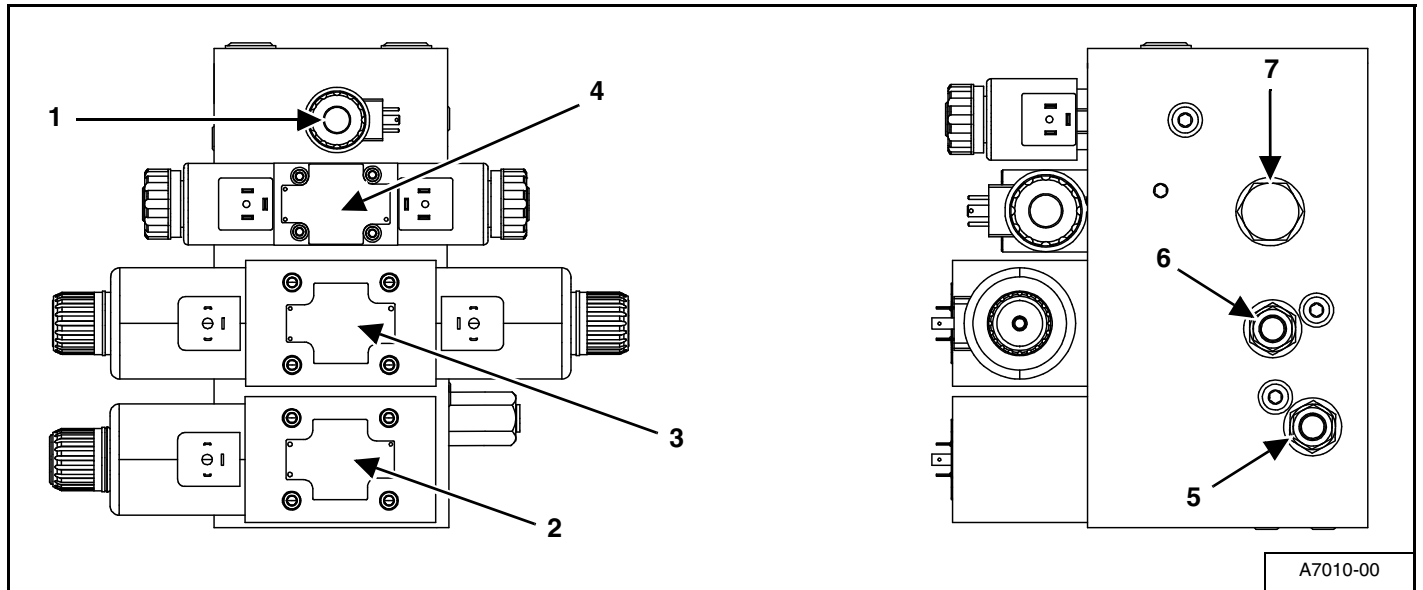

ITEM	PART NUMBER	DESCRIPTION
1	SZ000523	SVP, 10 - NO - 12 - DN - B
	SZ000524	COIL
	SZ000525	COIL NUT KIT
	SZ000516	SEAL KIT
2	SZ000526	DCV05 - 2C1 1 / 01200E1
	SZ000527	COIL
	SZ000528	COIL NUT KIT
	SZ000515	SEAL KIT
	SZ000529	MOUNTING SCREW KIT (1/4" - 20 x 1.625" SHCS)
3	SZ000530	DCV05 - 3Y11 / 01200E1
	SZ000527	COIL
	SZ000528	COIL NUT KIT
	SZ000515	SEAL KIT
	SZ000529	MOUNTING SCREW KIT (1/4" - 20 x 1.625" SHCS)
4	SZ000531	DCV03 - 3Y1 1 / 01200E1
	SZ000532	COIL
	SZ000533	COIL NUT KIT
	SZ000514	SEAL KIT
	SZ000534	MOUNTING SCREW KIT (10-24 UNC x 1.75" SHCS)
5	SZ000535	CP208 - 1 - B - 0 - A - C - 245
	SZ000536	SEAL KIT
6	SZ000537	CP208 - 1 - B - 0 - A - C - 080
	SZ000536	SEAL KIT
7	SZ000538	CV10 - NP - 5 - B
	SZ000539	SEAL KIT

**Manifold Hydraulic Schematic**

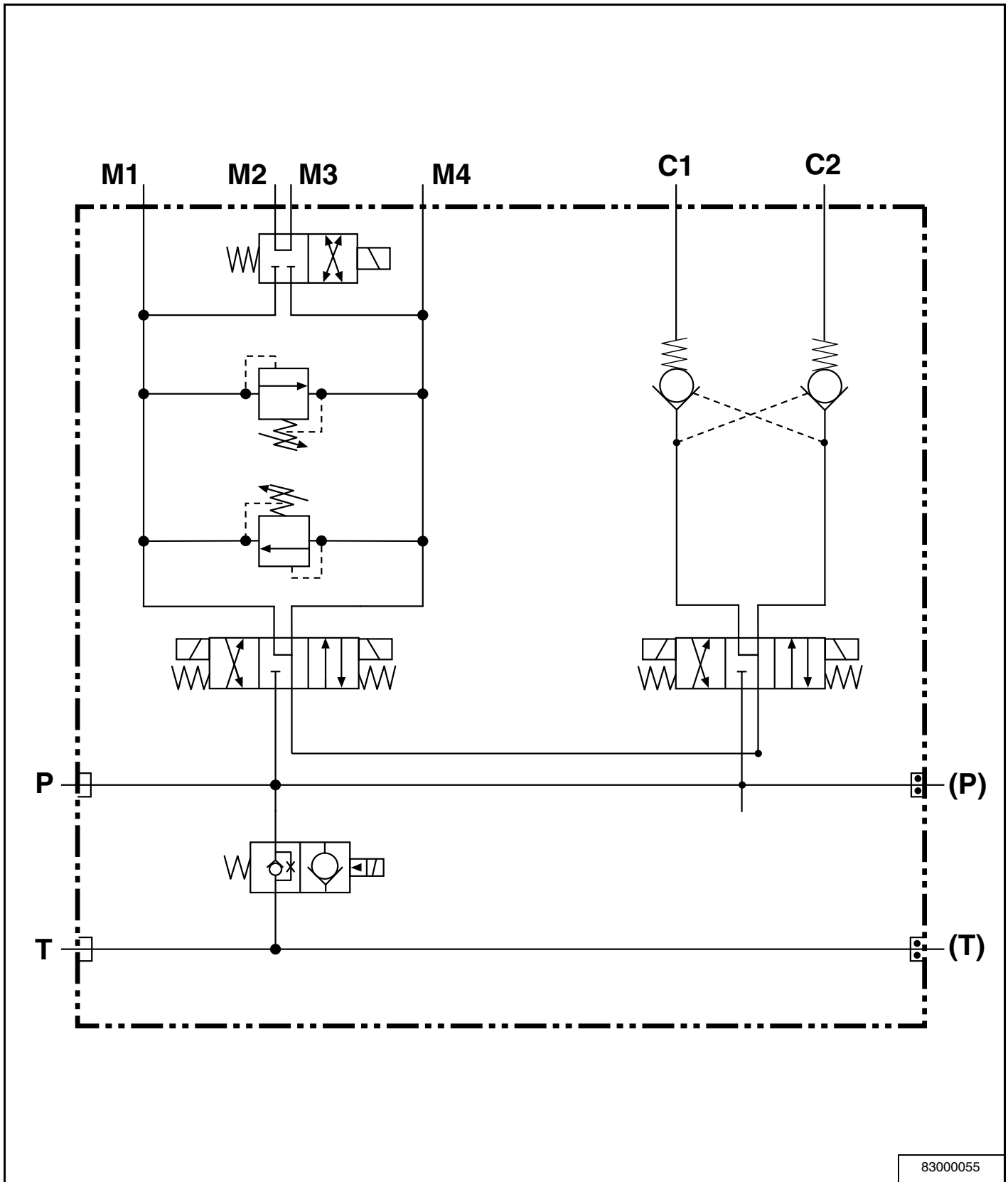

83000055

**High Pressure Line Assembly**

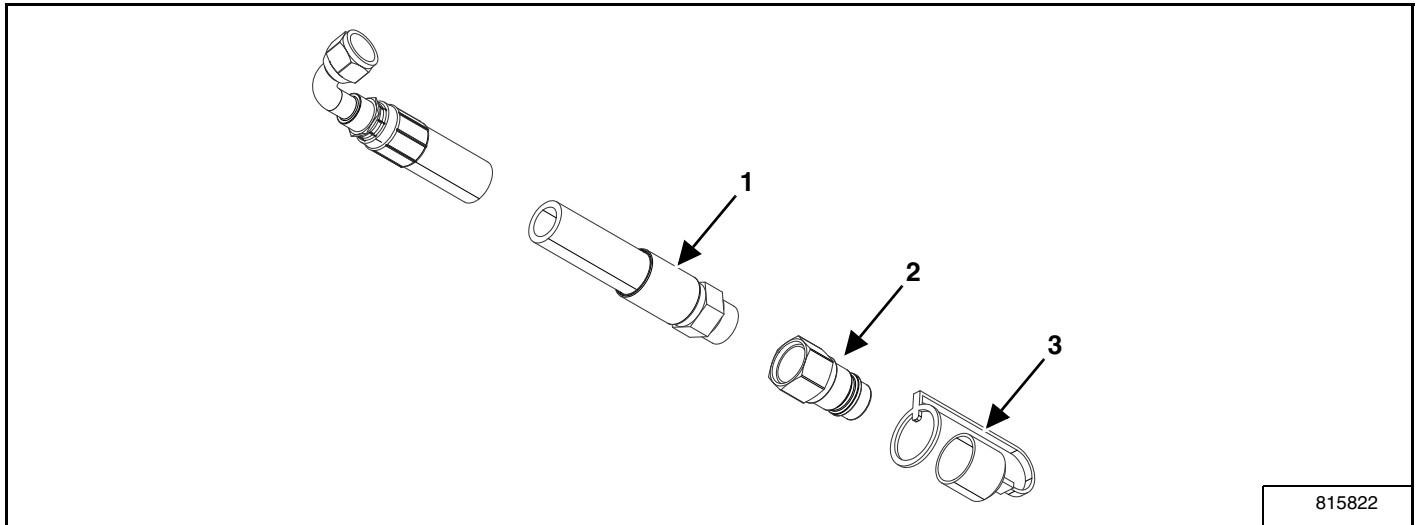

ITEM	PART NUMBER	DESCRIPTION	QTY
1	815824	HYDRAULIC HOSE, 1/2" x 142-7/8" MORB x 3/4" SWIVEL FJIC 90°	1
2	815177	MALE TIP, 0.5" BODY 7/8" ORB	1
3	813305	BLACK DUST CAP, 1/2"	1

**Hydraulic Return Line Assembly**

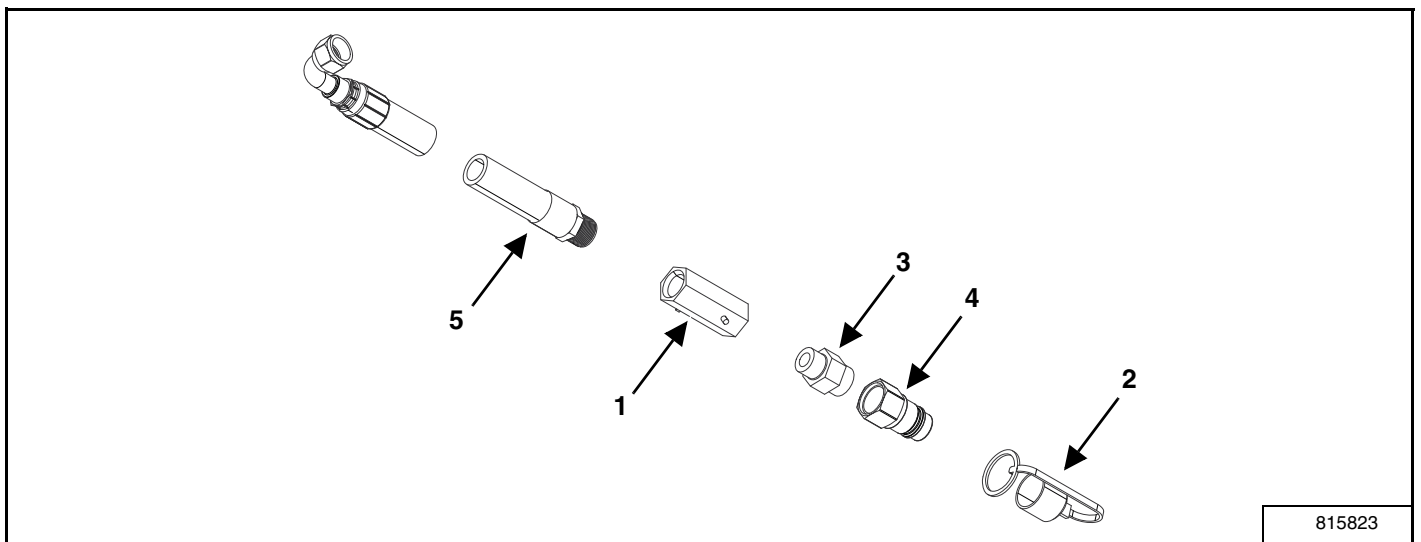

ITEM	PART NUMBER	DESCRIPTION	QTY
1	813666	CHECK VALVE, 3/4" ORB LINE	1
2	813305	BLACK DUST CAP, 0.5"	1
3	813088	STRAIGHT ADAPTER, 7/8" MORB x 3/4" MORB	1
4	815177	MALE TIP, 0.5" BODY 7/8" ORB	1
5	815834	HYDRAULIC HOSE, 1/2" x 142-3/4" MORB x 3/4" SWIVEL FJIC 90°	1

**Tilt Cylinder Extend Hydraulic Hose Assembly**

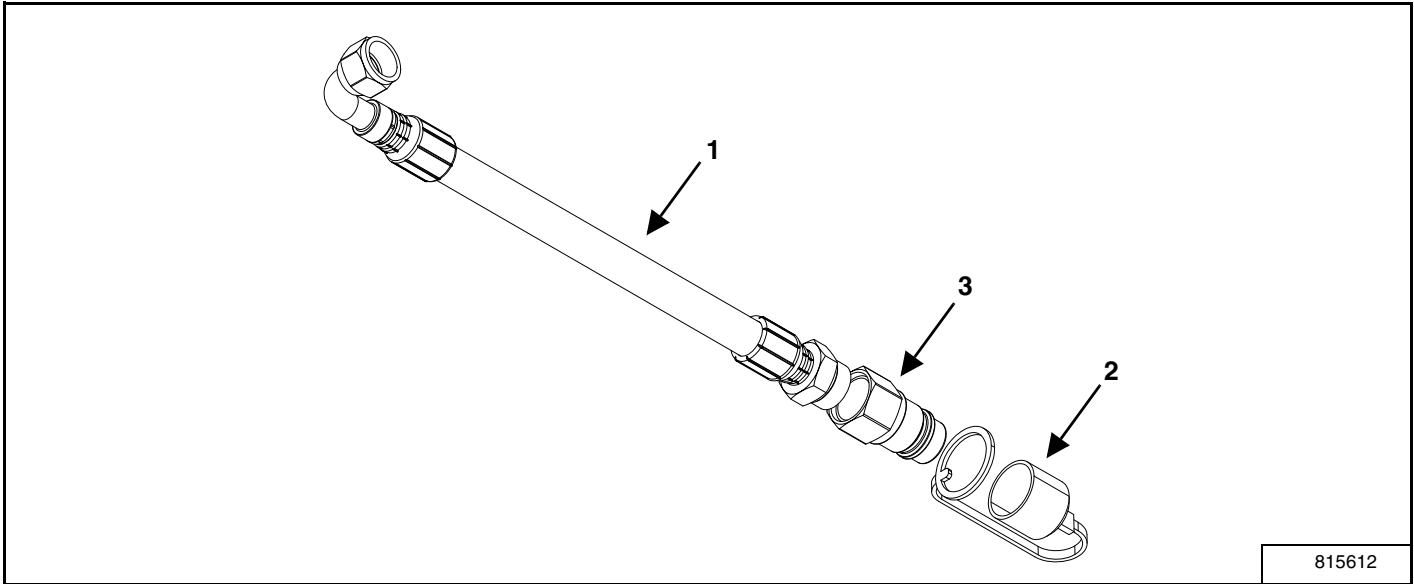

815612

ITEM	PART NUMBER	DESCRIPTION	QTY
1	815613	HYDRAULIC HOSE, 3/8" x 192-7/8" MORB x 3/4" SWIVEL FJIC 90°	1
2	813303	RED DUST CAP, 0.5"	1
3	815177	MALE TIP, 0.5" BODY 7/8" ORB	1

**Tilt Cylinder Retract Hydraulic Hose Assembly**

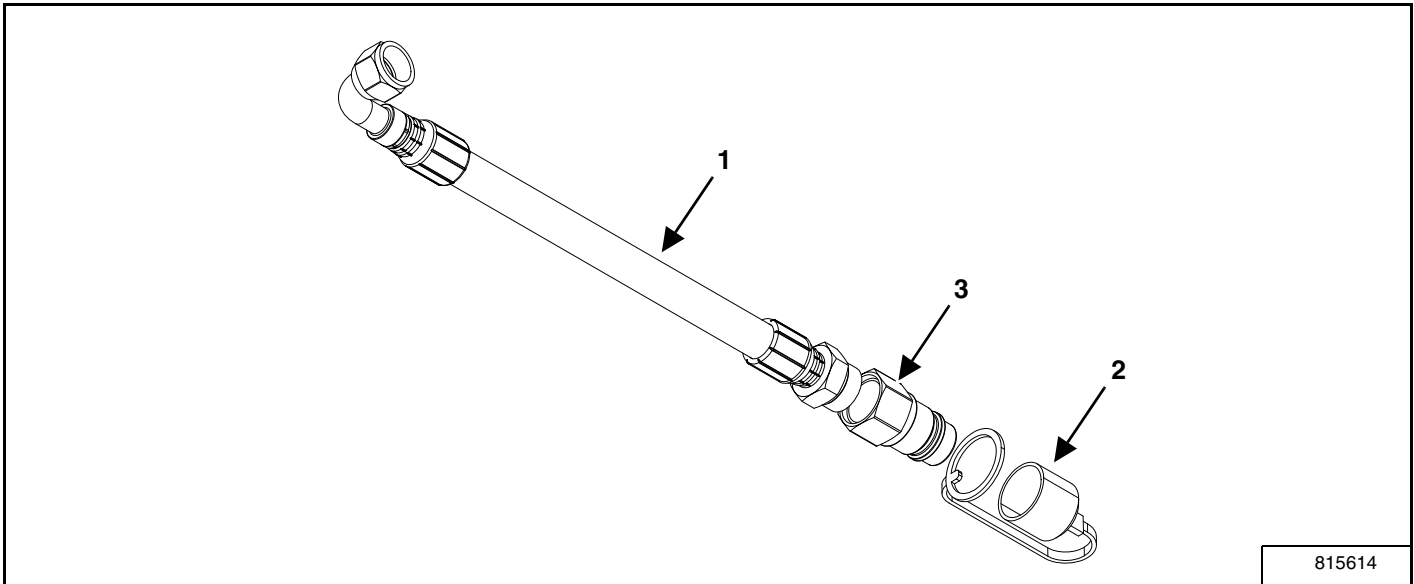

815614

ITEM	PART NUMBER	DESCRIPTION	QTY
1	815613	HYDRAULIC HOSE, 3/8" x 192-7/8" MORB x 3/4" SWIVEL FJIC 90°	1
2	813303	RED DUST CAP, 0.5"	1
3	815177	MALE TIP, 0.5" BODY 7/8" ORB	1

**Lift Arm Cylinder Assembly**

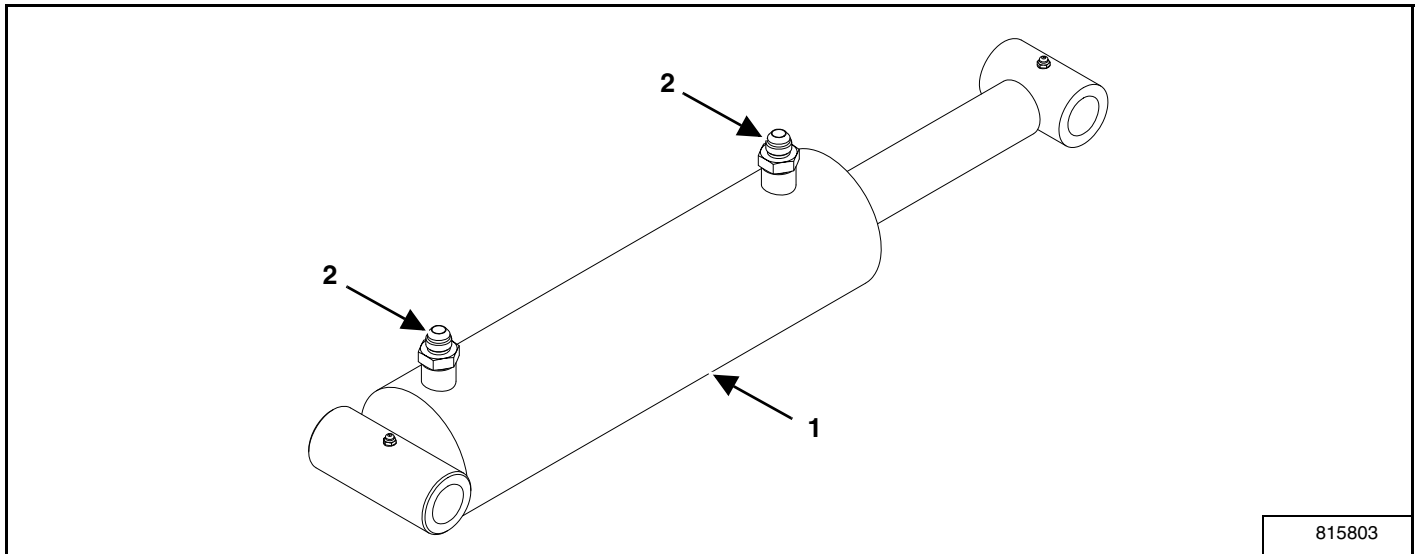

815803

ITEM	PART NUMBER	DESCRIPTION	QTY
1	815804M	CYLINDER, 4.0" x 12.0"	1
2	886897	STRAIGHT ADAPTER, 7/8" MORB x 3/4" MJIC	2
<b>815804M SERVICE PARTS</b>			
-	X3916	SEAL KIT	1

**Tilt Cylinder Assembly**

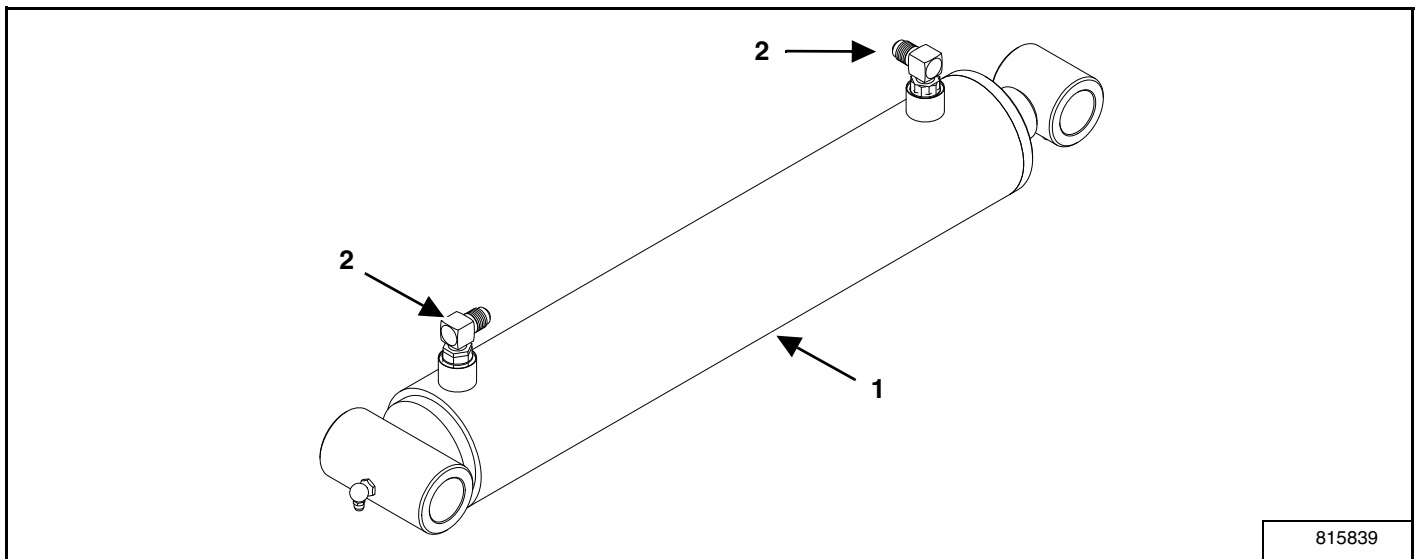

815839

ITEM	PART NUMBER	DESCRIPTION	QTY
1	815840M	CYLINDER, 3.0" x 16.0"	1
2	813640	90° ELBOW, 9/16" MORB ADJ x 3/8"	2
<b>815840M SERVICE PARTS</b>			
-	X3914	SEAL KIT	1

**Pusher Motor Assembly**

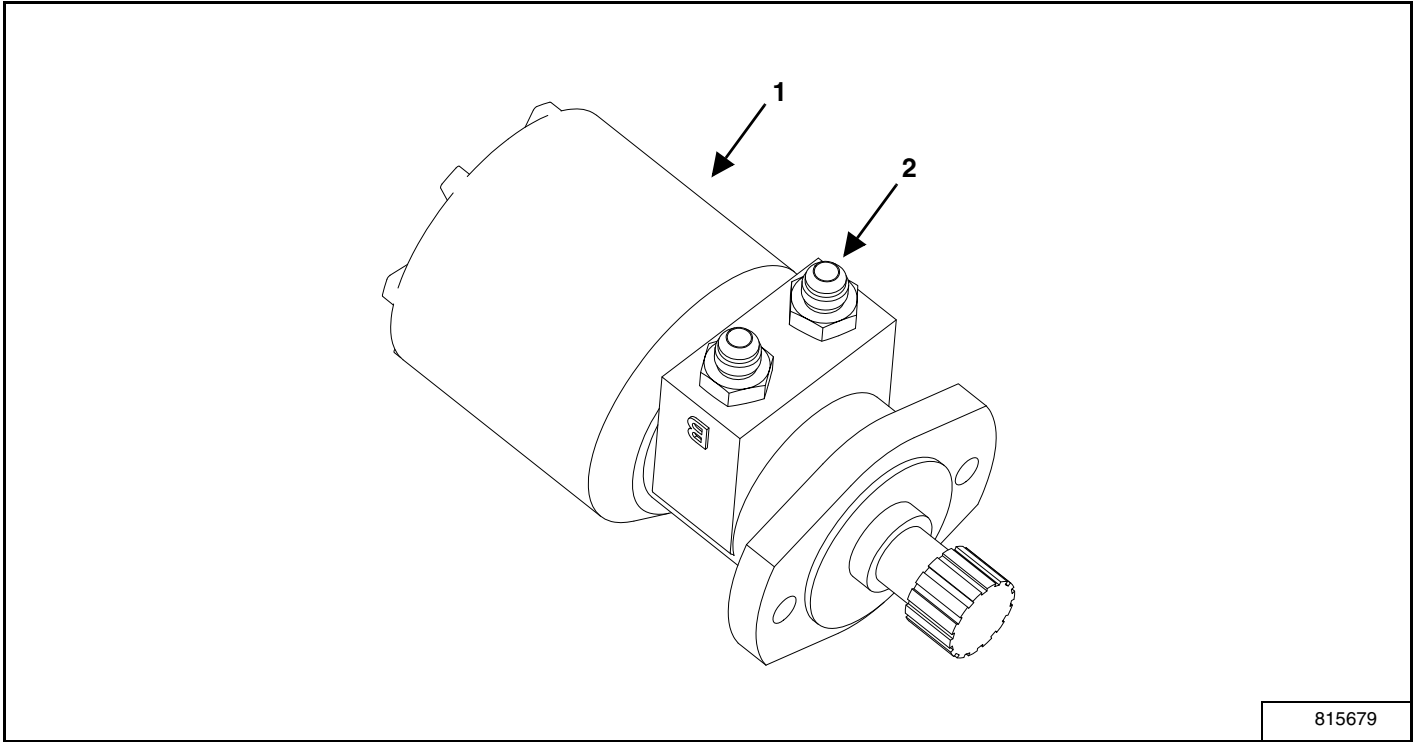

ITEM	PART NUMBER	DESCRIPTION	QTY
1	B2799-00	MOTOR, 22.2 CUBIC INCH	1
2	886897	STRAIGHT ADAPTER, 7/8" MORB x 3/4" MJIC	2
<b>B2799-00 SERVICE PARTS</b>			
-	X2725	SEAL KIT	1

**Hydraulic Assembly Hardware**

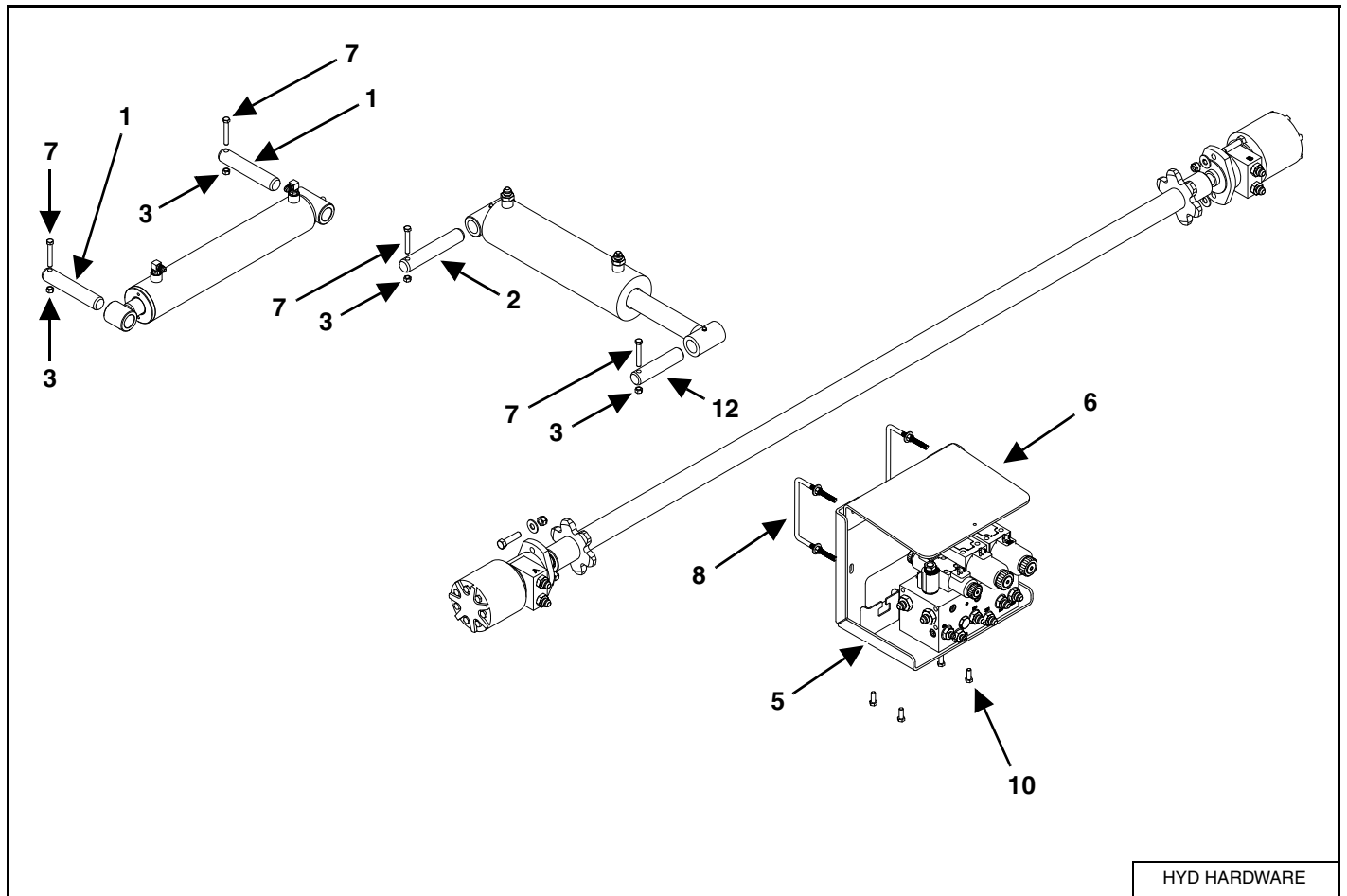

ITEM	PART NUMBER	DESCRIPTION	QTY
1	112954	PIN, 1.25" DIA. x 6.75" LG	2
2	113698	PIN, 1.25" DIA. x 7.13" LG	1
3	812363	LOCK NUT, 0.375" GRB (STEEL) (PL)	4
4	813663	LOCK NUT, 0.500" NC GRC (STEEL) (PL)	4
5	815737-26	VALVE BRACKET WELDMENT	1
6	815739-26	MANIFOLD COVER	1
7	81581	BOLT, 0.375" x 2.50" LG HEX	4
8	815857	U-BOLT, 3/8" DIA. x 6" W x 4.625" L	2
9	84048	FLAT WASHER, 0.500" (PI)	4
10	86170	BOLT, 0.375" UNC x 1.0" LG HEX	4
11	967275	BOLT, 0.500" UNC x 2.00" GR8 PL	4
12	E2445-00	PIN, 1.25" DIA. x 5.625" LG	1

**Frame Assembly (Top View)**

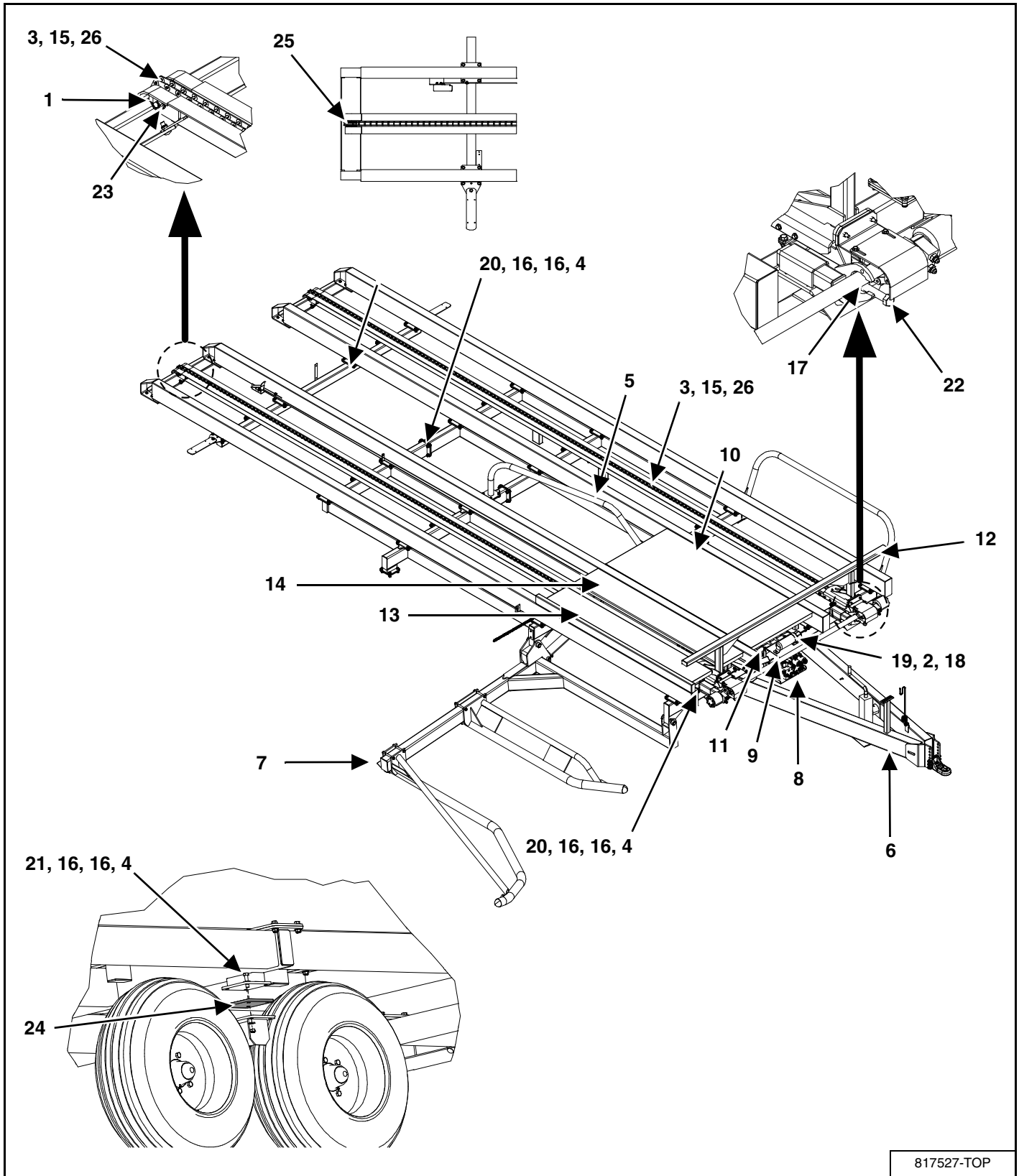

817527-TOP



ITEM	PART NUMBER	DESCRIPTION	QTY
1	811795	BOLT, 3/8" x 2" HEX (PL)	2
2	812026	BOLT, 5/16" x 1" HEX (PL)	4
3	813643	CONNECTOR LINK, HD C2080	4
4	813663	NUT LOCK, 0.500" NC (STEEL) GR C (PL)	56
5	815689	BALE DIVERTER	1
6	815699	HITCH ASSEMBLY	1
7	815709	RH LIFT ARM ASSEMBLY	1
8	815736	MANIFOLD ASSEMBLY	1
9	815739	MANIFOLD COVER	1
10	815805	PLATFORM WELDMENT	1
11	815857	U-BOLT, 3/8" x 6" W x 4.625" L	2
12	817540	ASSEMBLY - PUSHER	1
13	817550	WELDMENT - RHS BALE RAMP	1
14	817551	WELDMENT - LHS BALE RAMP	1
15	817554	CHAIN, 632" LENGTH (316 PITCHES)	2
16	84048	FLAT WASHER, 1/2" SAE (PL)	112
17	84051	JAM NUT, 1.00" NC HEX GR 2	2
18	84541	LOCK NUT, 0.313" NC (NYLON)	4
19	909277	MANUAL HOLDER	1
20	967274	BOLT, 0.500 NC x 1.50 HEX GR 8 (PL)	40
21	967275	BOLT, 0.500" NC x 2.00" HEX GR 8 (PL)	16
22	C2768-00	BOLT, 1" x 6" HEX (PL)	2
23	E2345-00	PIN CYLINDER, 1.0" DIA x 4.25"	2
24	INE2401-01	AXLE BOLT PLATE	4
25	INE7037-00	ROLLER / CHAIN GUIDE	2
26	SZ000589	2080H OFFSET LINK	2

**Frame Assembly (Bottom View)**

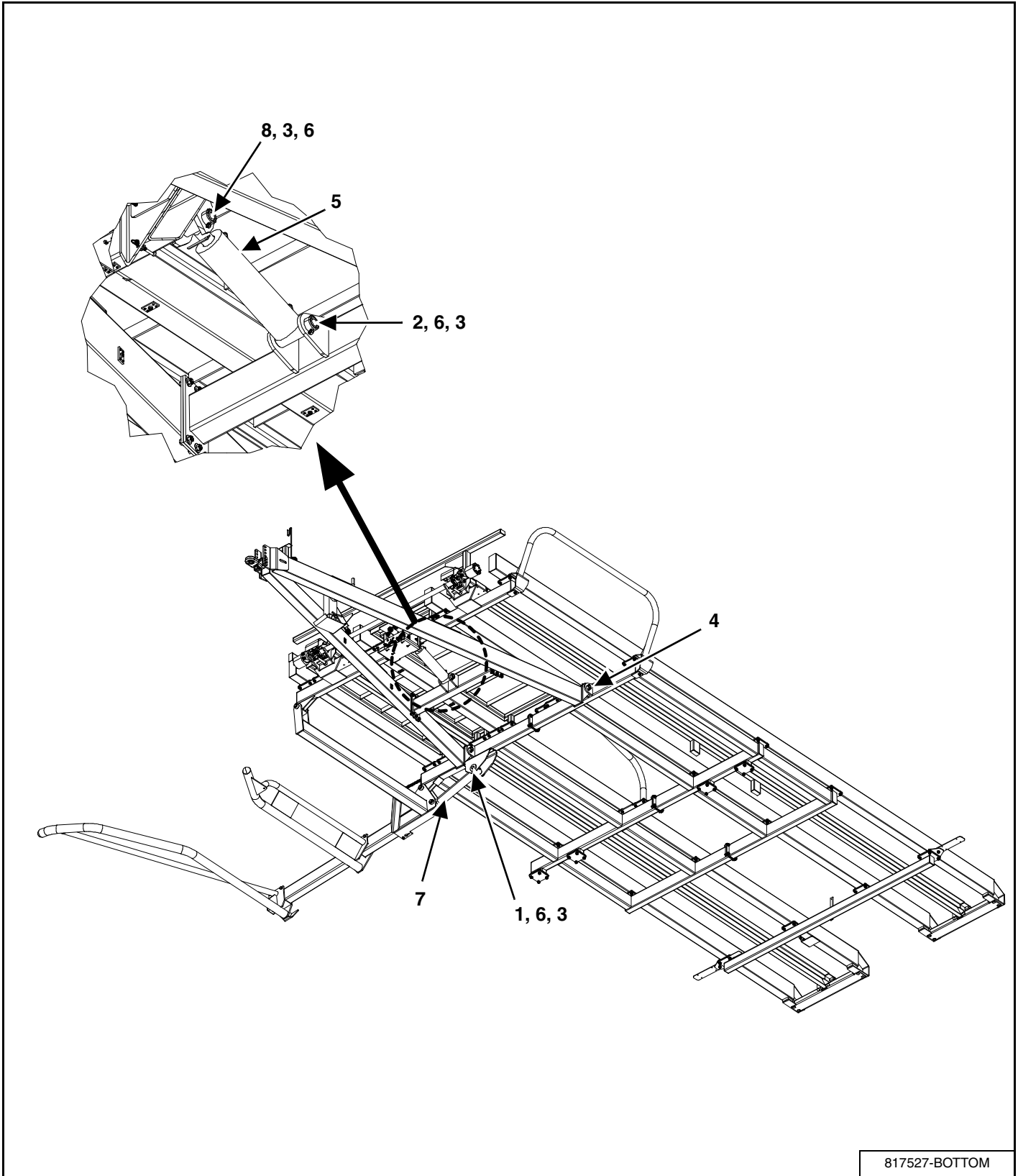

817527-BOTTOM

ITEM	PART NUMBER	DESCRIPTION	QTY
1	112954	PIN, 1.25" x 6.75" LG	1
2	113698	PIN, 1.25" x 7.13" LG LDR 86015933	1
3	812363	LOCK NUT, 3/8" (PL)	7
4	815379	PIN, 1.25" x 3.75" LG	2
5	815803	CYLINDER ASSEMBLY, 4" x 12"	1
6	81581	BOLT, 0.375" x 2.50" HEX	5
7	815839	CYLINDER ASSEMBLY, 3.0" x 16.0" W / FITTINGS	1
8	E2445-00	LIFT ARM PIN, 1.25" C1045CR	1

Carrier Frame Assembly

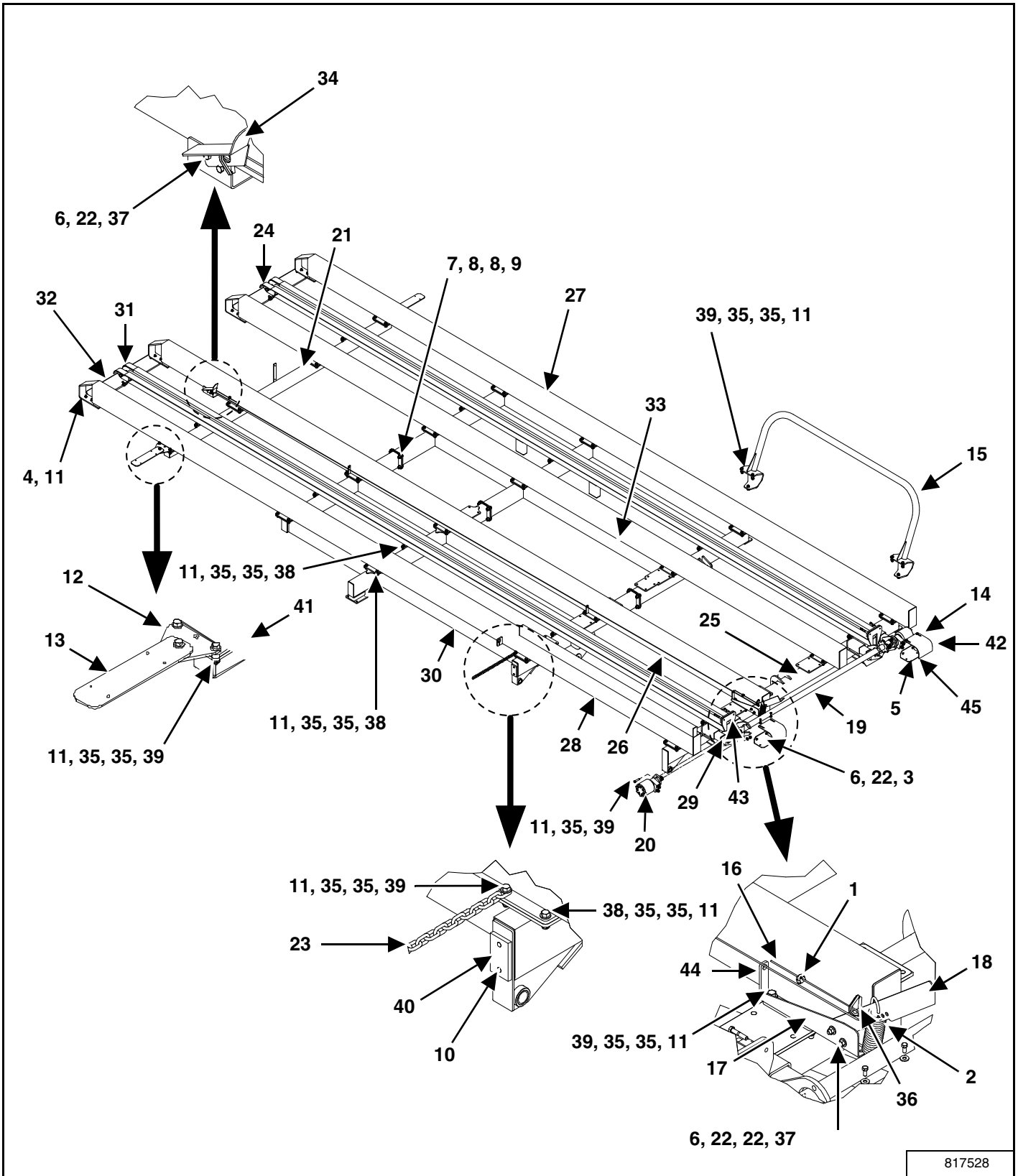

817528

ITEM	PART NUMBER	DESCRIPTION	QTY
1	21417	CABLE CLAMP, 1/8"	2
2	28556	SAFETY LOCK SPRING	1
3	811795	BOLT, 3/8" x 2" HEX (PL)	4
4	812217	CARRIAGE BOLT, 1/2" x 1-1/2" (PL)	12
5	812362	LOCK NUT, 5/16" (PL)	4
6	812363	LOCK NUT, 3/8" (PL)	8
7	812482	LOCK NUT, 5/8" (PL)	12
8	812639	FLAT WASHER, 0.625" SAE BS (PL)	24
9	813053	BOLT, 0.625" NC x 1.50" HEX GR 5 (PL)	12
10	813602	FLATHEAD RIVET 1/4" x 3/4"	2
11	813663	LOCK NUT, 0.500" NC (STEEL) GR C (PL)	120
12	815372	INNER LIGHT BRACKET	2
13	815373	OUTER LIGHT BRACKET	2
14	81549	BOLT, 5/16" x 3/4" HEX (PL)	4
15	815622	BALE RETAINER WELDMENT	1
16	815674	BALE FULL INDICATOR CABLE	1
17	815675	FULL INDICATOR BRACKET	1
18	815676	FRONT INDICATOR	1
19	815677	MOTOR SPROCKET WELDMENT	1
20	815679	MOTOR ASSEMBLY, 22.2 CU IN	2
21	815682	REAR CROSSMEMBER	1
22	81570	FLAT WASHER, 3/8" STD (PL)	14
23	815830	LIFT ARM TRANSPORT CHAIN	1
24	817530	LHS CHAIN GUIDE WELDMENT	1
25	817534	FRONT CROSSMEMBER WELDMENT	1
26	817535	INSIDE RIGHT CARRIER WELDMENT	1
27	817536	LEFT CARRIER WELDMENT	2
28	817537	OUTSIDE RIGHT CARRIER WELDMENT	1
29	817544	MOTOR MOUNT WELDMENT	2
30	817545	RHS SUBFRAME WELDMENT	1
31	817546	RHS CHAIN GUIDE WELDMENT	1
32	817547	REAR CHAIN GUIDE SUPPORT PLATE	2
33	817583	LHS SUBFRAME WELDMENT	1
34	83000018	RH REAR INDICATOR WELDMENT	1
35	84048	FLAT WASHER, 1/2" SAE (PL)	212
36	84154	CABLE THIMBLE, 3/16"	2
37	86170	BOLT, 3/8" x 1" HEX GR 5 (PL)	4
38	967274	BOLT, 0.500" NC x 1.50" HEX GR 8 (PL)	90
39	967275	BOLT, 0.500" NC x 2.00" HEX GR 8 (PL)	18
40	E2413-00	ARM CUSHION RUBBER BELTING	1
41	E2937-00	LIGHTING KIT PLATE, 1500 / 2500	1
42	E7039-00	CHAIN DRIVE SHIELD	2
43	E7040-00	CUSHION PUSHER / STOP	2
44	I100236	CABLE HOLDER	3
45	INE7038-00	MOUNTING BRACKET / SHIELD	2

Electrical Assembly

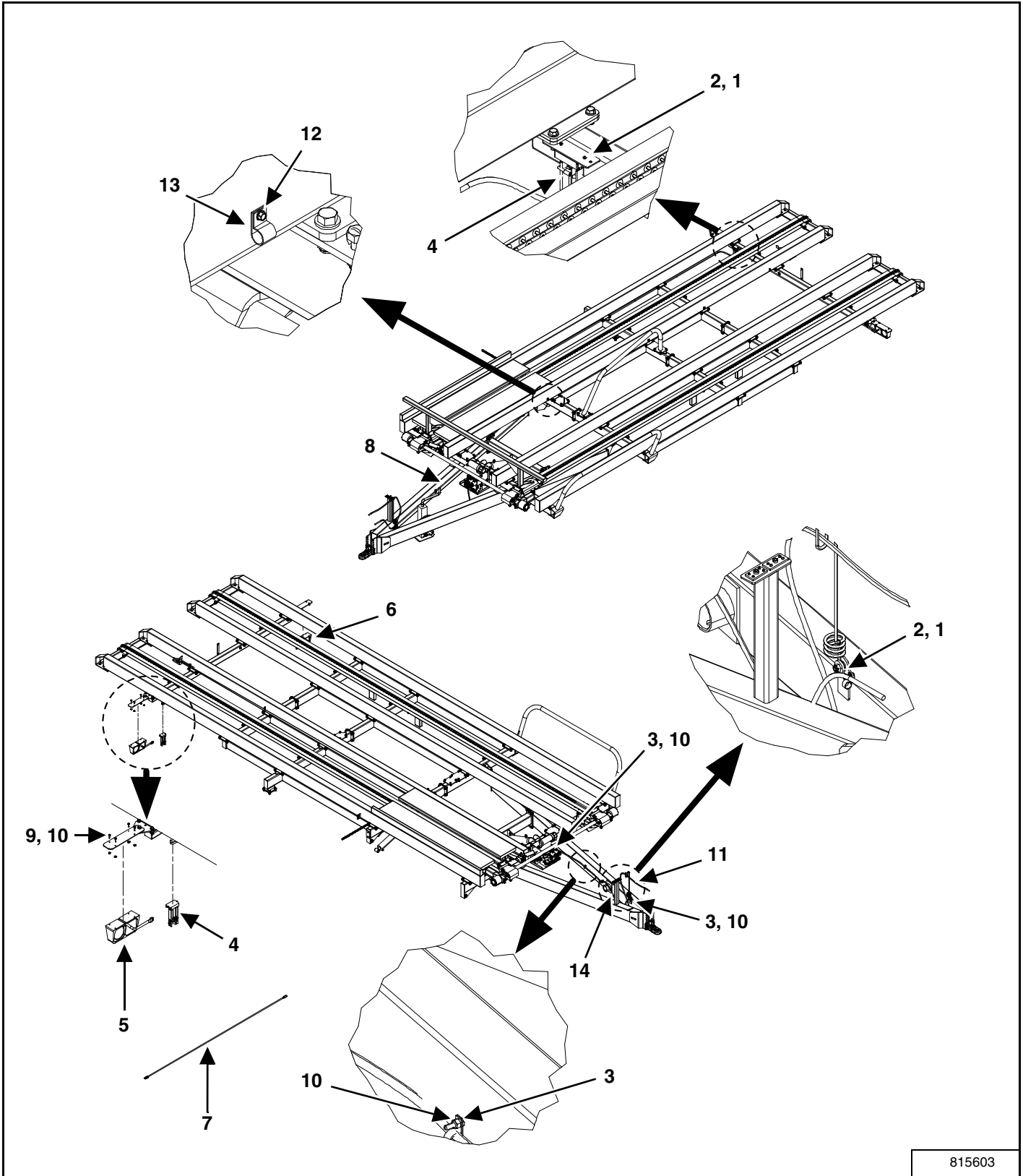

ITEM	PART NUMBER	DESCRIPTION	QTY
1	812537	LOCK NUT, 0.136" NC (NYLON) GR B PL	2
2	813958	MACHINE SCREW, #8-32 x 0.75" FLAT HD	2
3	814063	WIRING HARNESS CLAMP	4
4	814193	ENHANCED AG LIGHTING MODULE	1
5	814195	RH DUAL / AG / LAMP, 4-WAY WP	1
6	814196	LH DUAL / AG / LAMP, 4-WAY WP	1
	816015	AMBER LENS COVER	As Required
	816016	RED LENS COVER	As Required
7	814197	EXTENSION HARNESS, 114" LG	1
8	814198	MAIN HARNESS, 48' LONG - 7 PIN PLUG	1
9	81527	BOLT, 1/4" x 1" HEX (PL)	2
10	81922	LOCK NUT, 0.25" (NYLON) NC	4
11	I20024	1500 CONTROL HANDLE ASSEMBLY	-
12	SZ000565	SELF-TAPPING SCREW, 5/16"-12 x 3/4" #3 PNT	8
13	SZ000566	VINYL DIP CLAMP, 5/16" x 0.406" HOLE	10
14	SZ000567	WHA BALE CARRIER MANIFOLD	1

Electrical Schematic (Prior to S/N BM240013000061)

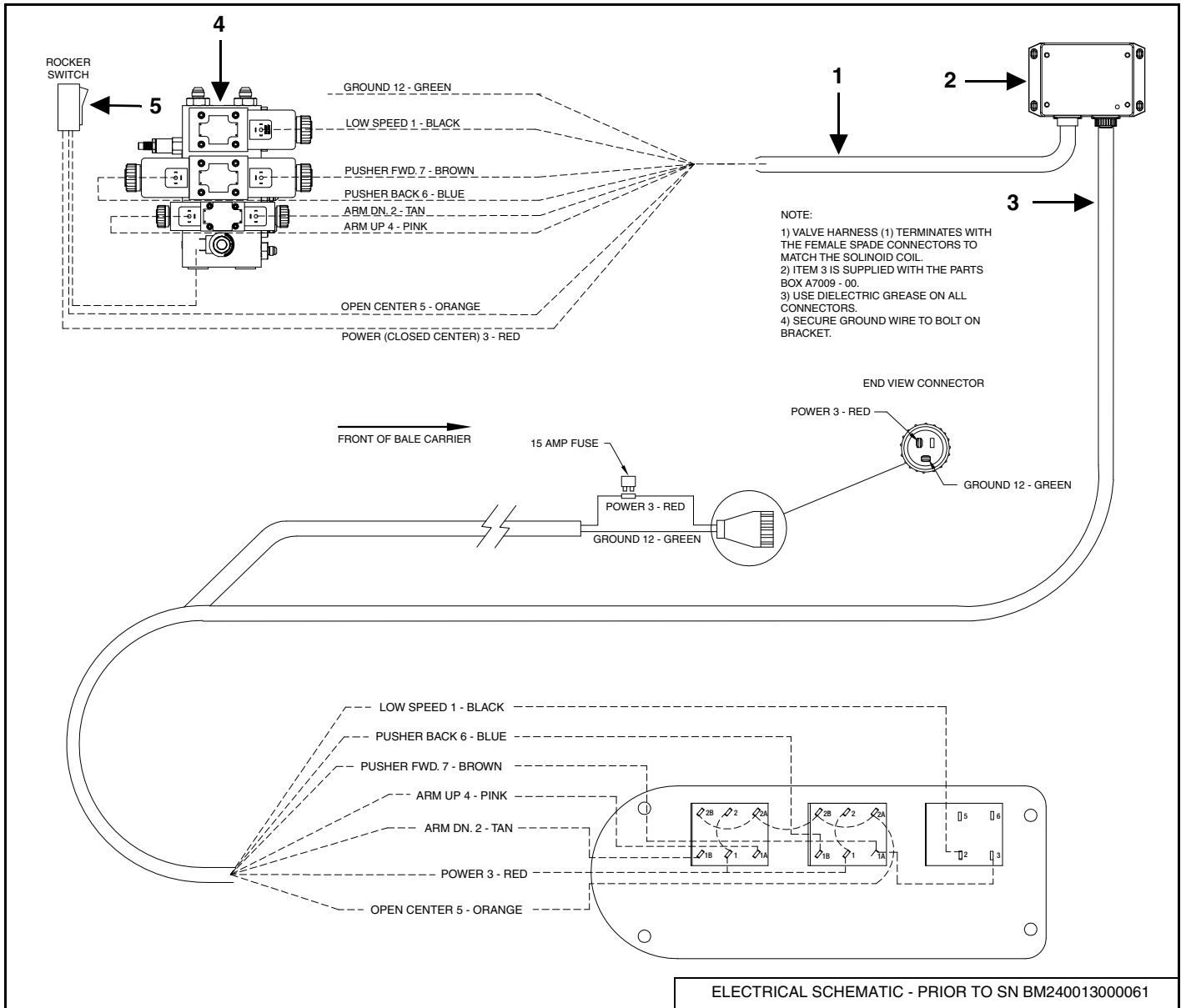

ITEM	PART NUMBER	DESCRIPTION	QTY
1	815620	MACHINE HARNESS 2400	1
2	813949	SNUBBER UNIT	1
3	I20024	CONTROL HANDLE HARNESS ASSEMBLY 2400	1
4	815846	VALVE BANK ASSEMBLY 2400	1
5	SZ000759	OPEN / CLOSED SWITCH	1
<b>OPTIONAL</b>			
-	A4000-00	TRACTOR POWER EXTENSION KIT	1



Electrical Schematic (2018 and later)

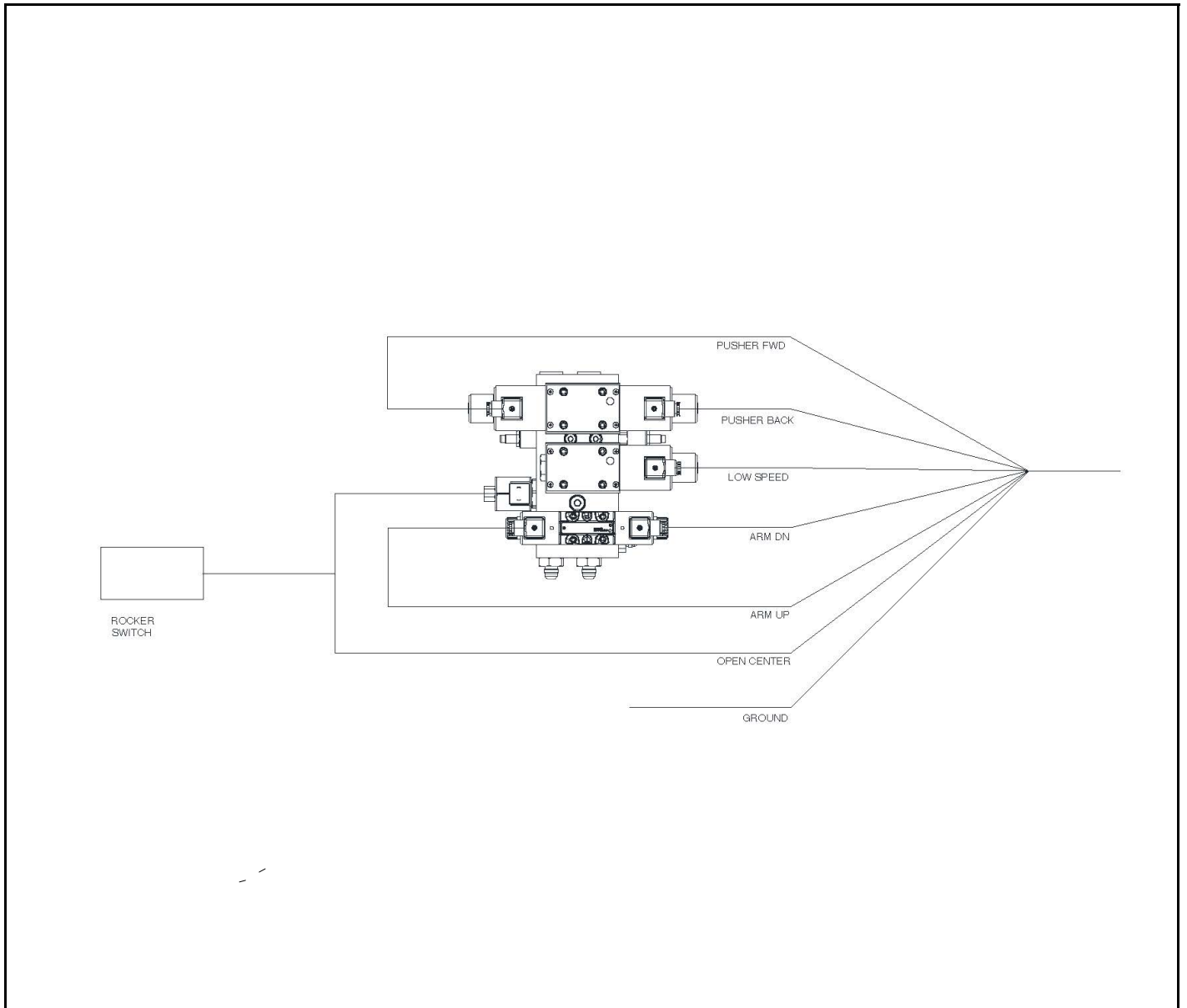

**Control Handle Assembly**

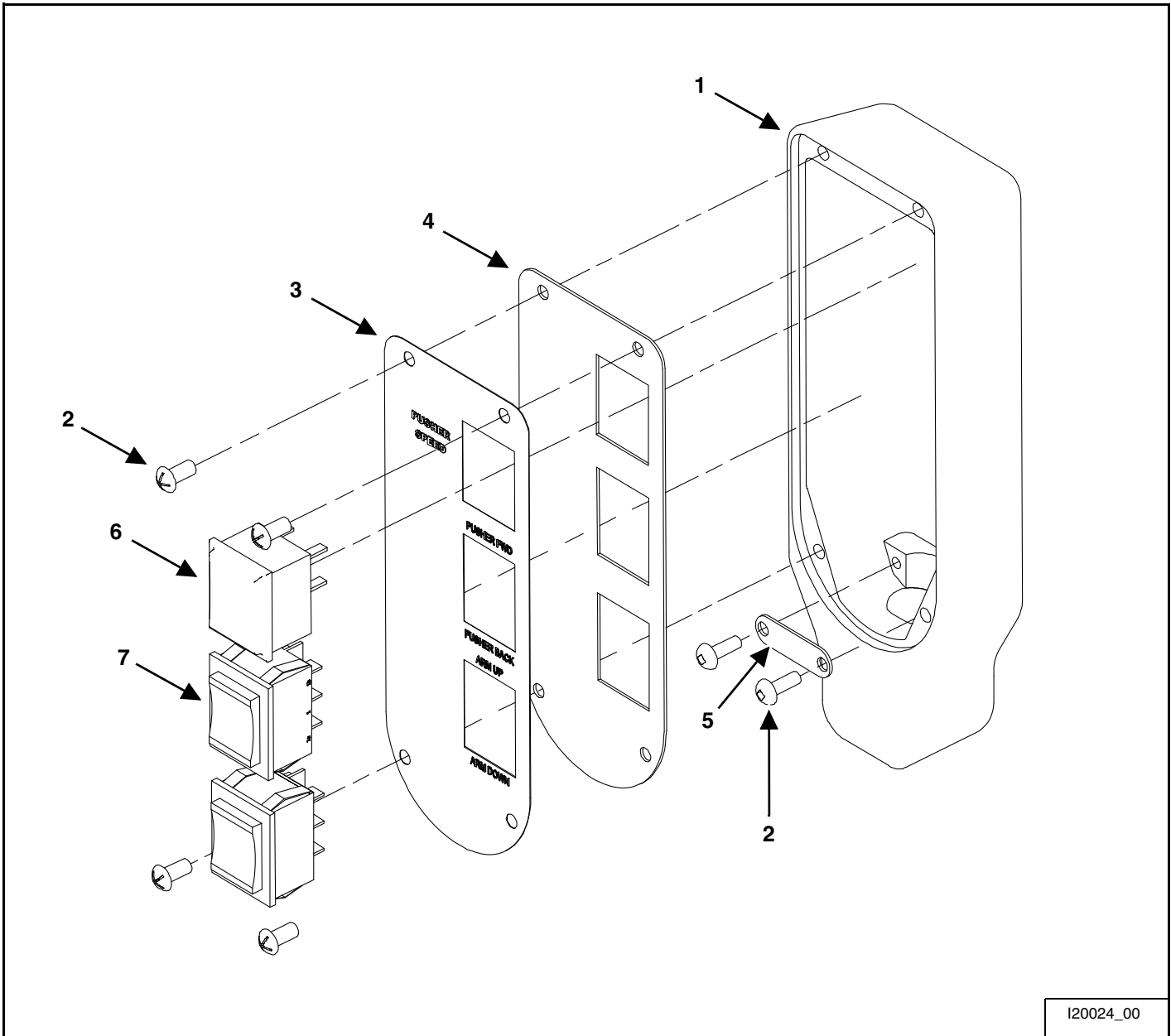

ITEM	PART NUMBER	DESCRIPTION	QTY
1	22105	CONTROL HANDLE	1
2	813540	SCREW, 8-32 x 0.50"	6
3	815851	SWITCH COVER DECAL - 2400	1
4	I100016	SWITCH COVER PLATE - 2400	1
5	INE22105-01	WIRE CLAMP PLATE	1
6	815382	ROCKER SWITCH ON - OFF	1
7	815383	ROCKER SWITCH (ON) - OFF - (ON)	2

**Tire Assembly**

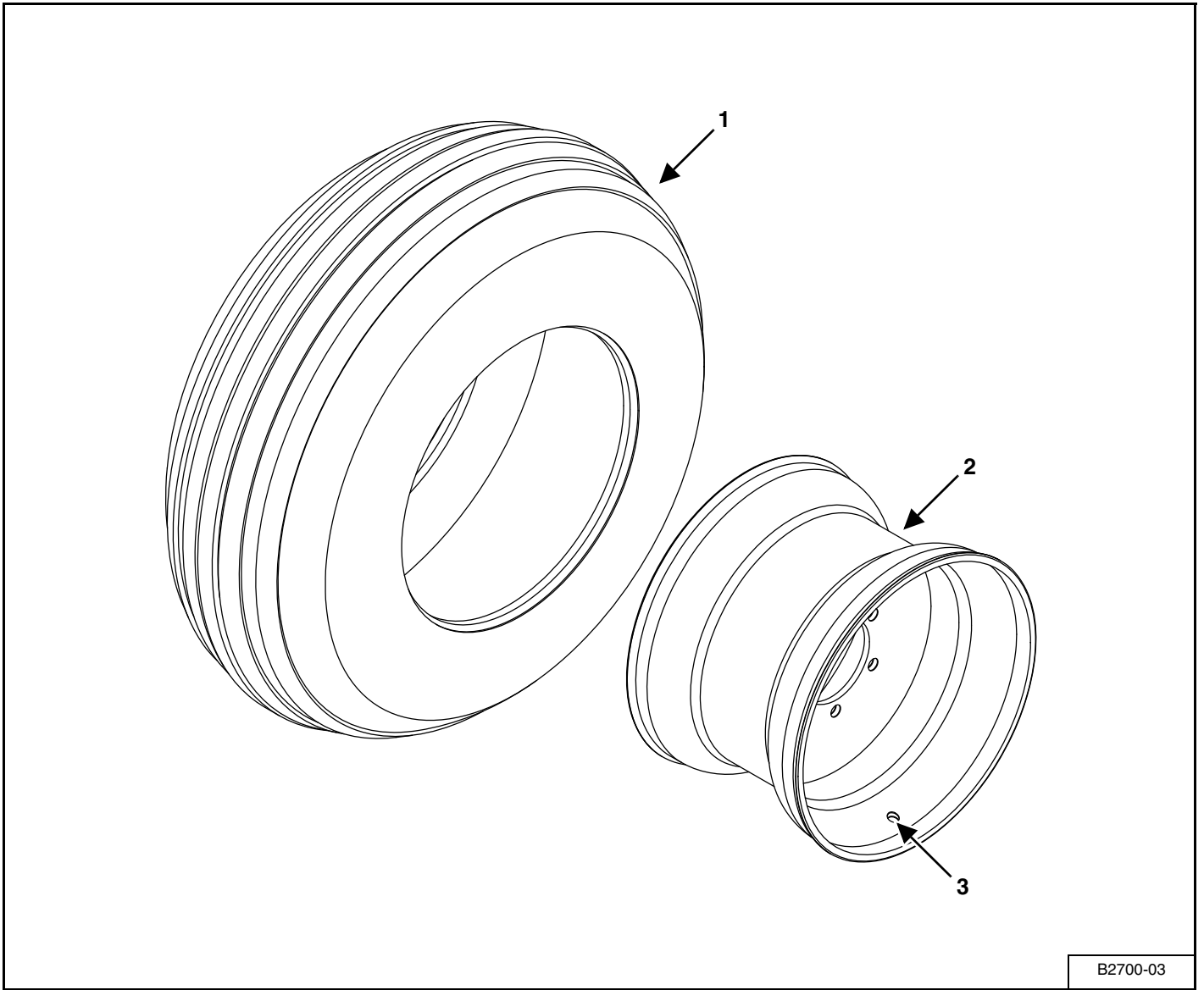

B2700-03

ITEM	PART NUMBER	DESCRIPTION	QTY
1	813657	TIRE, 12.5L x 15FI	1
2	813655	RIM, 15 x 10LB x 6 BOLT P65	1
3	813656	VALVE STEM / TUBELESS RIM	1

**Tandem Axle Assembly W / Two Hubs**

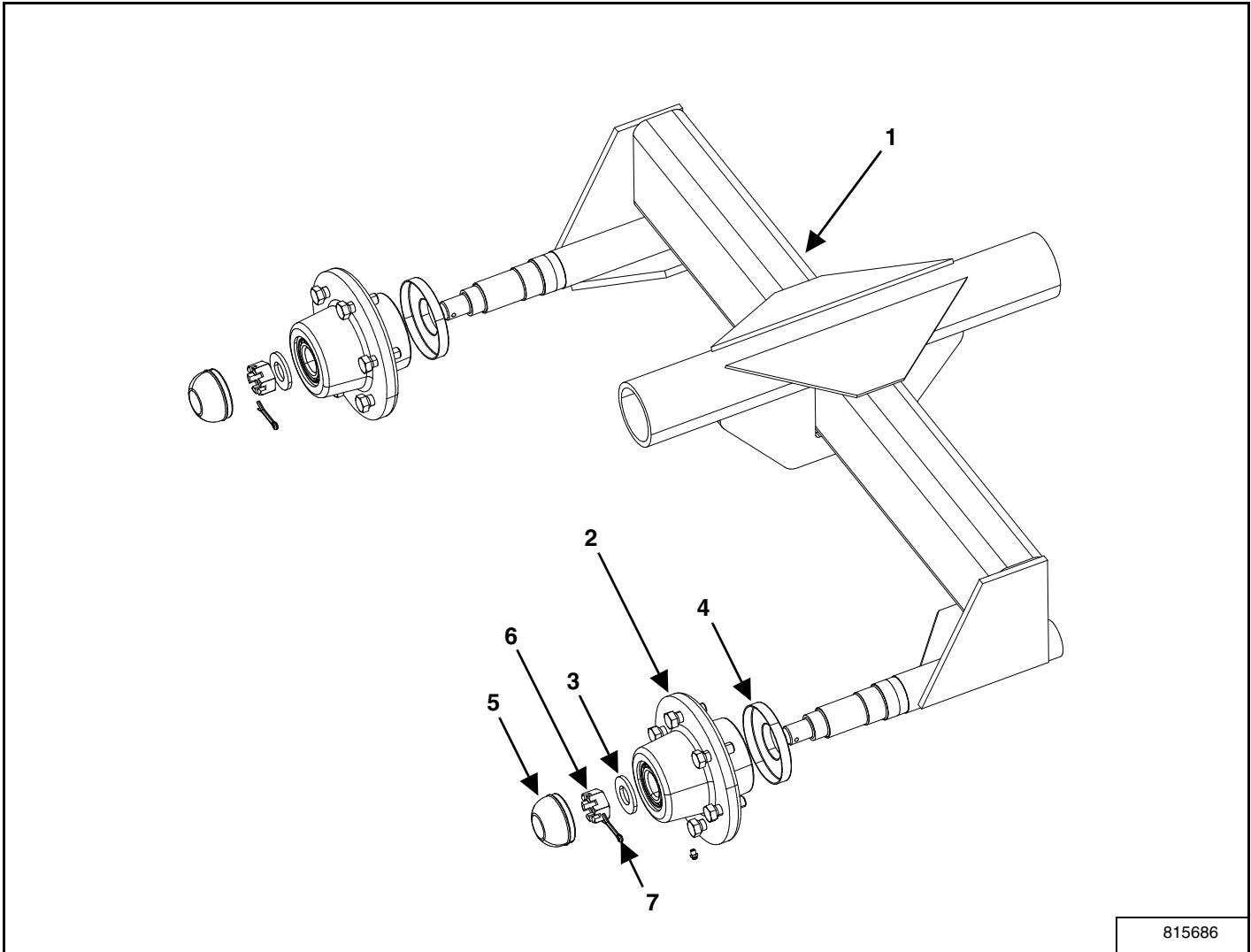

ITEM	PART NUMBER	DESCRIPTION	QTY
1	815687	TANDEM AXLE WELDMENT, W / TWO HUBS	1
2	C2339-00	6 BOLT HUB	2
3	13651	FLAT WASHER, 2.0" x 1.03" x 0.19" W / HUB	2
4	813649	DUST SHIELD	2
5	813650	DUST CAP	2
6	812871	CASTLE NUT, 1.25" GR 2	2
7	9812433	COTTER PIN, 3/16" x 1.50" BR	2

**Tandem Axle Assembly W / Four Hubs**

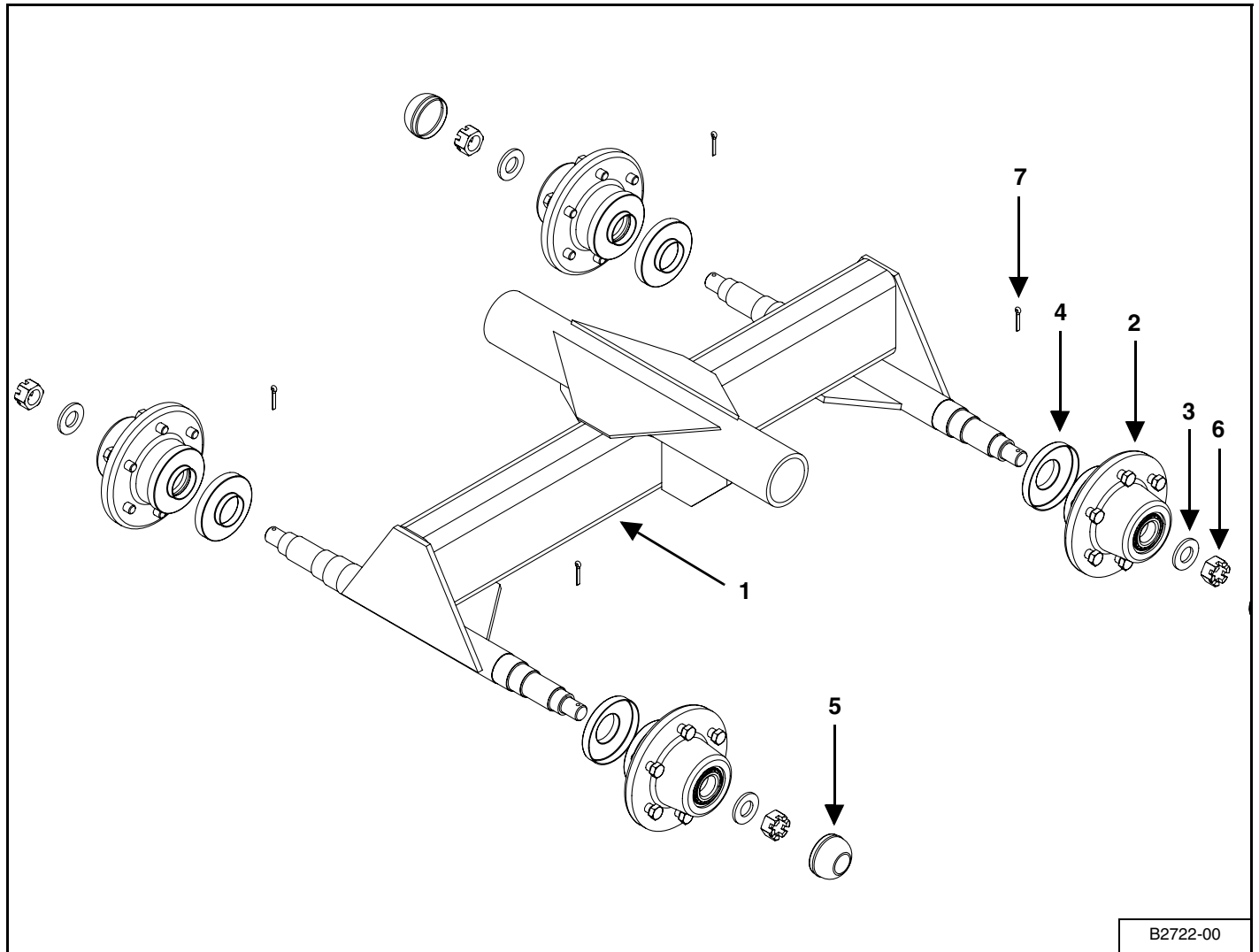

B2722-00

ITEM	PART NUMBER	DESCRIPTION	QTY
1	C2722-00	TANDEM AXLE WELDMENT, W / FOUR HUBS	1
2	C2339-00	6 BOLT HUB	4
3	13651	FLAT WASHER, 2.0" x 1.03" x 0.19" W / HUB	4
4	813649	DUST SHIELD	4
5	813650	DUST CAP	4
6	812871	CASTLE NUT, 1.25" GR 2	4
7	9812433	COTTER PIN, 3/16" x 1.50" BR	4

**Hub Assembly**

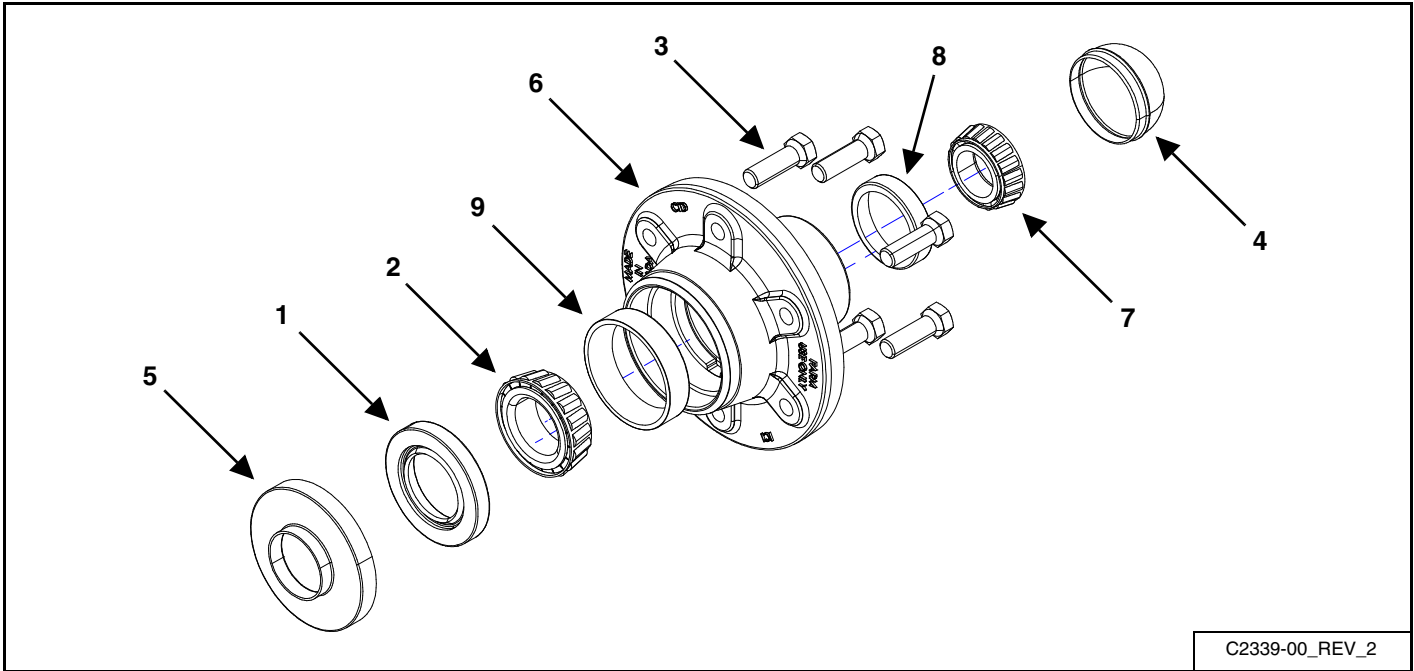

ITEM	PART NUMBER	DESCRIPTION	QTY
1	967204	OIL SEAL, 9CTD - SE30	1
2	967208	OUTER BEARING CONE (LM48548)	1
3	813653	BOLT, 0.563" NF x 1.75" (WB12) / HUB	6
4	813650	DUST CAP DC15	1
5	813649	DUST SHIELD DC16	1
6	813652	6 BOLT WHEEL HUB (HA-618)	1
7	967205	INNER BEARING CONE (25580)	1
8	SZ100152	OUTER BEARING CUP, (LM48510)	1
9	SZ625520	INNER BEARING CUP, 1-3/4" (25520)	1

**Pusher Assembly**

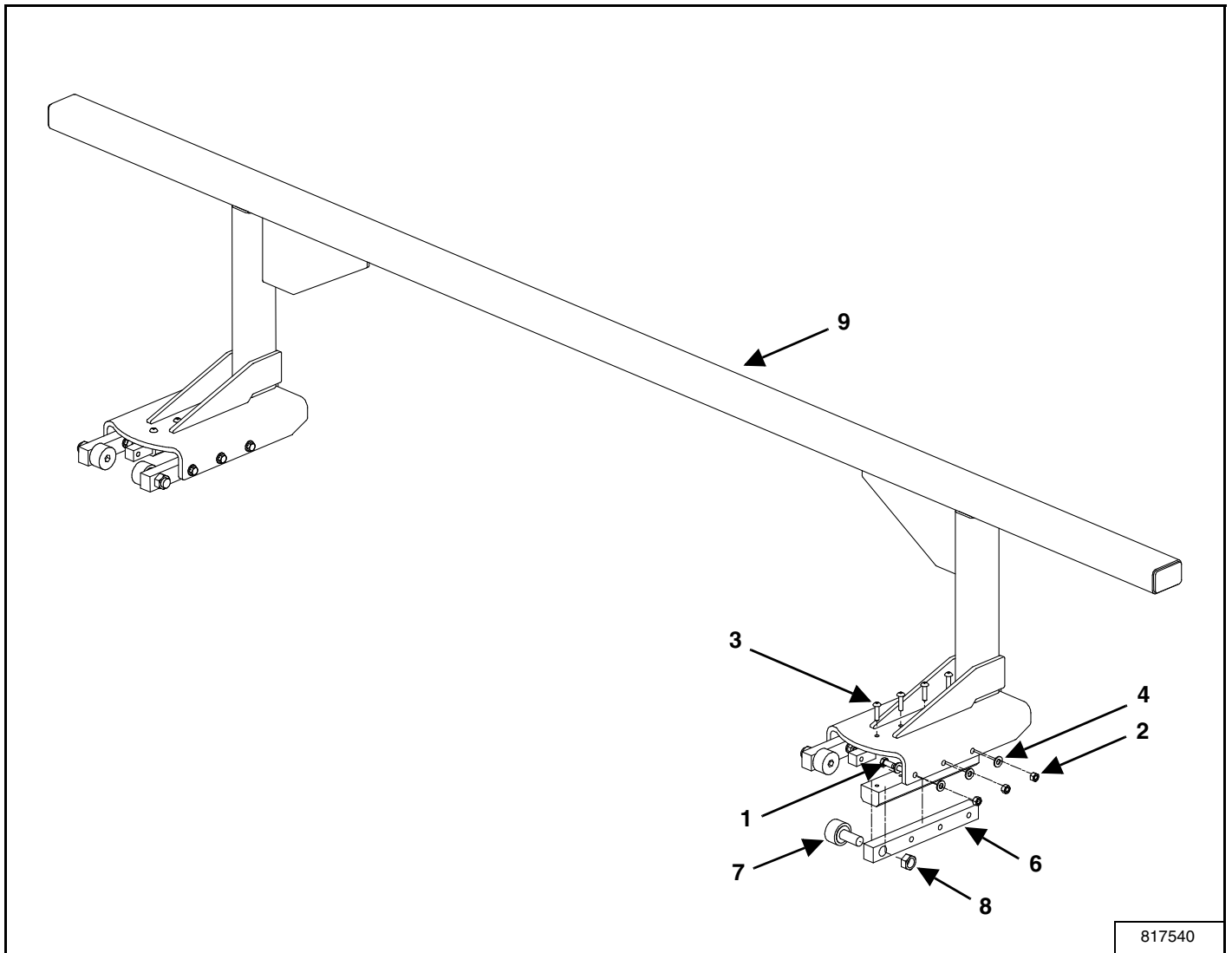

ITEM	PART NUMBER	DESCRIPTION	QTY
1	811795	BOLT, 3/8" x 2" HEX (PL)	12
2	812363	LOCK NUT, 3/8" (PL)"	12
3	813644	MACHINE SCREW, 0.313" NC x 1.25" RD HD	8
4	81570	FLAT WASHER, 0.375" ST HS (PL)	24
5	815715	MIDDLE SLIDER	2
6	815778	BAR TRACK ROLLER	4
7	815779	TRACK ROLLER, 1-3/4" DIA	4
8	815827	NUT, 3/4"-16 NF HEX GR B	4
9	817541	PUSHER WELDMENT	1

**Roller / Chain Guide Assembly**

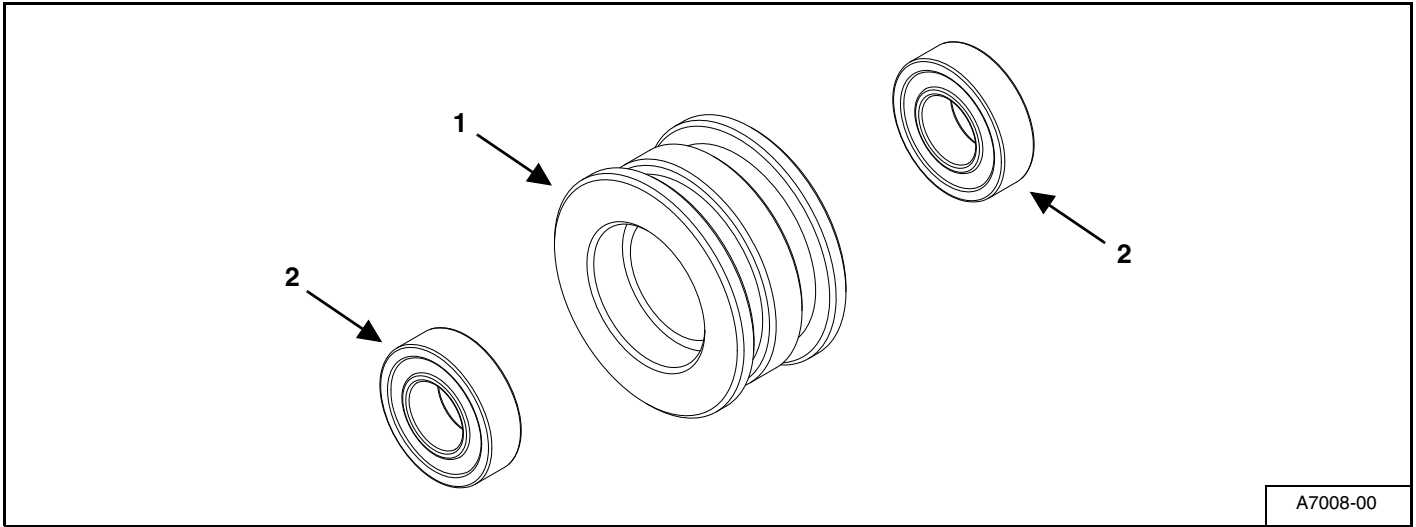

ITEM	PART NUMBER	DESCRIPTION	QTY
1	INE7037-00	ROLLER / CHAIN GUIDE	1
2	813645	BEARING, 6205LLU / 25.4 / 3E	2



**Pick Up Arm W / Deflector Assembly**

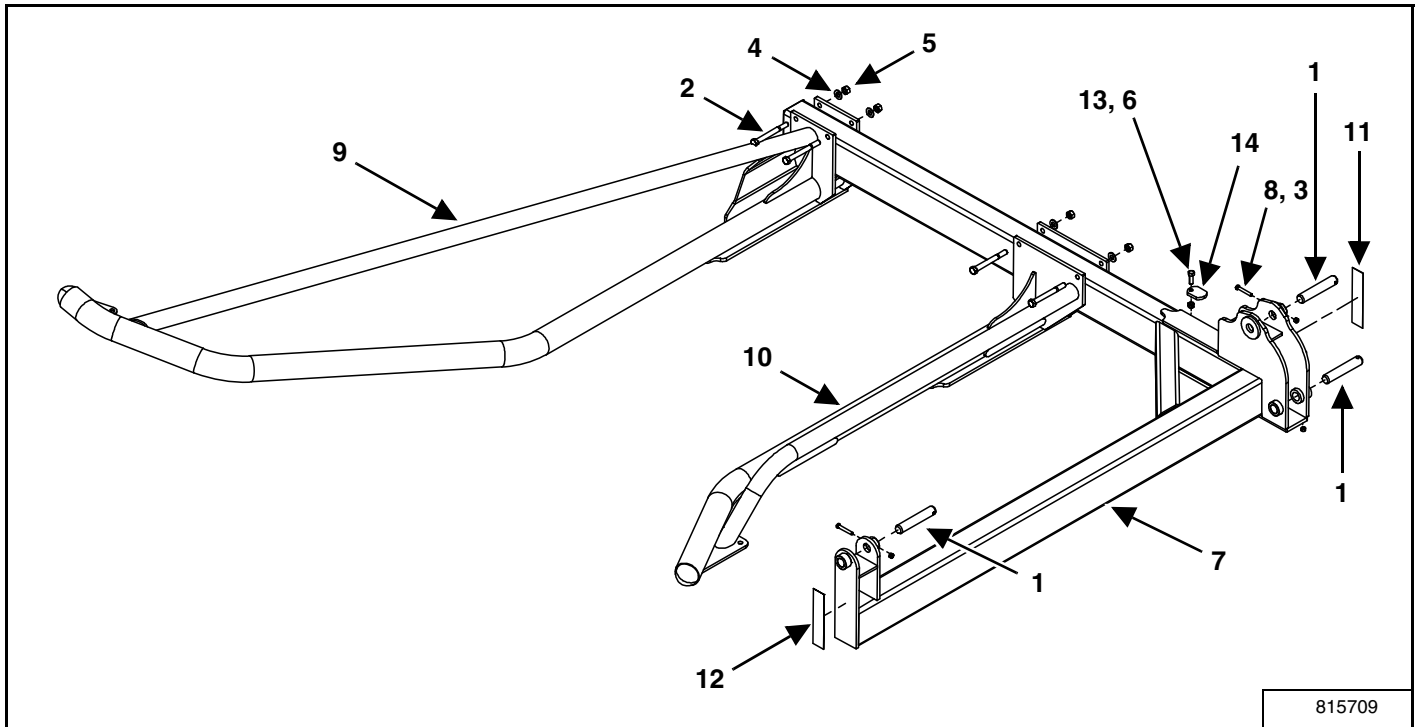

ITEM	PART NUMBER	DESCRIPTION	QTY
1	112954	PIN, 1.25" DIA. x 6.75" LG	3
2	812087	BOLT, 5/8" x 6" HEX (PL)	4
3	812363	LOCK NUT, 3/8" (PL)	3
4	812639	FLAT WASHER 0.625" SAE BS (PL)	4
5	813509	NUT, 0.625" NC HEX GR 5 (PL)	4
6	813663	NUT LOCK (STEEL) 0.500NC GR C (PL)	1
7	815710	RIGHT BALE LIFT ARM	1
8	81581	BOLT 0.375" x 2.50" HEX	1
9	817620	QUARTER - TURN FORK WELDMENT	1
10	817621	INSIDE FORK WELDMENT, 2400	1
11	967053	RED REFLECTIVE DECAL, 2" x 9"	1
12	967055	AMBER REFLECTIVE DECAL, 2" x 9"	1
13	967274	BOLT, 0.500" NC x 1.50" HEX GR 8 (PL)	1
14	E2485-00	LIFT ARM CHAIN LATCH	1

**Hitch Assembly**

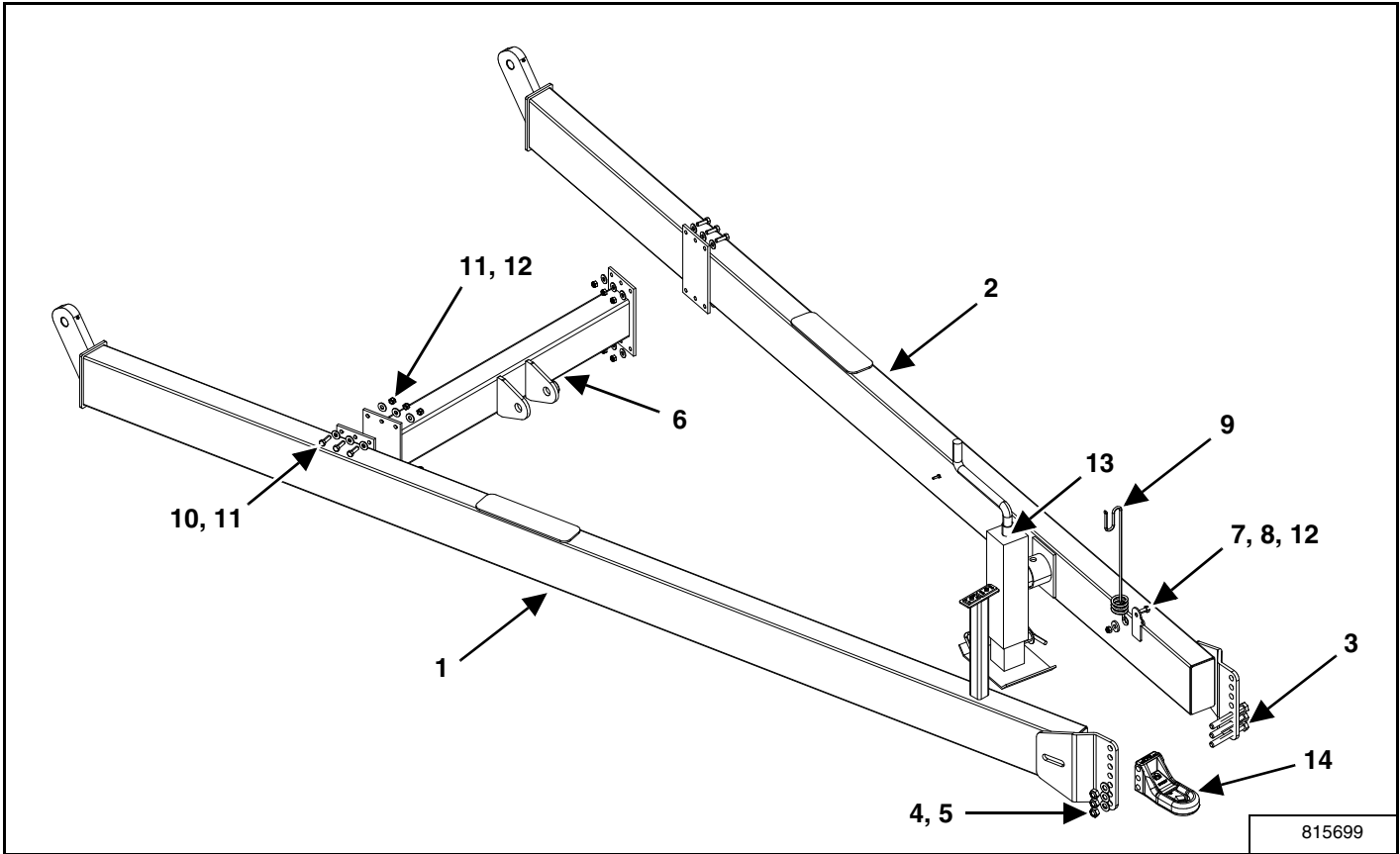

ITEM	PART NUMBER	DESCRIPTION	QTY
1	815706-26	RH HITCH WELDMENT	1
2	815702-26	LH HITCH WELDMENT	1
3	00047589	BOLT, 0.750" NC x 6" LG HEX GR 8 (PL)	3
4	813648	LOCK NUT, 0.750" NC (STEEL) GR C (PL)	3
5	84050	FLAT WASHER, 0.750" SAE BS (PL)	3
6	815700-26	HITCH CROSSMEMBER	1
7	81620	BOLT, 0.500" NC x 1.25" HEX GR 5 (PL)	1
8	813581	FLAT WASHER, 1.5" x 0.531" x 0.25" (PL)	1
9	813662	HOSE HOLDER	1
10	967274	BOLT, 0.500" NC x 1.50" GR 8 (PL)	12
11	84048	FLAT WASHER, 0.500" SAE BS (PL)	24
12	813663	LOCK NUT, 0.500" NC (Steel) GR C (PL)	13
13	815378	5 TON SCREW JACK	1
14	SZ000561	PERFECT HITCH	1

**Optional Adjustable Bale Stop Assembly**

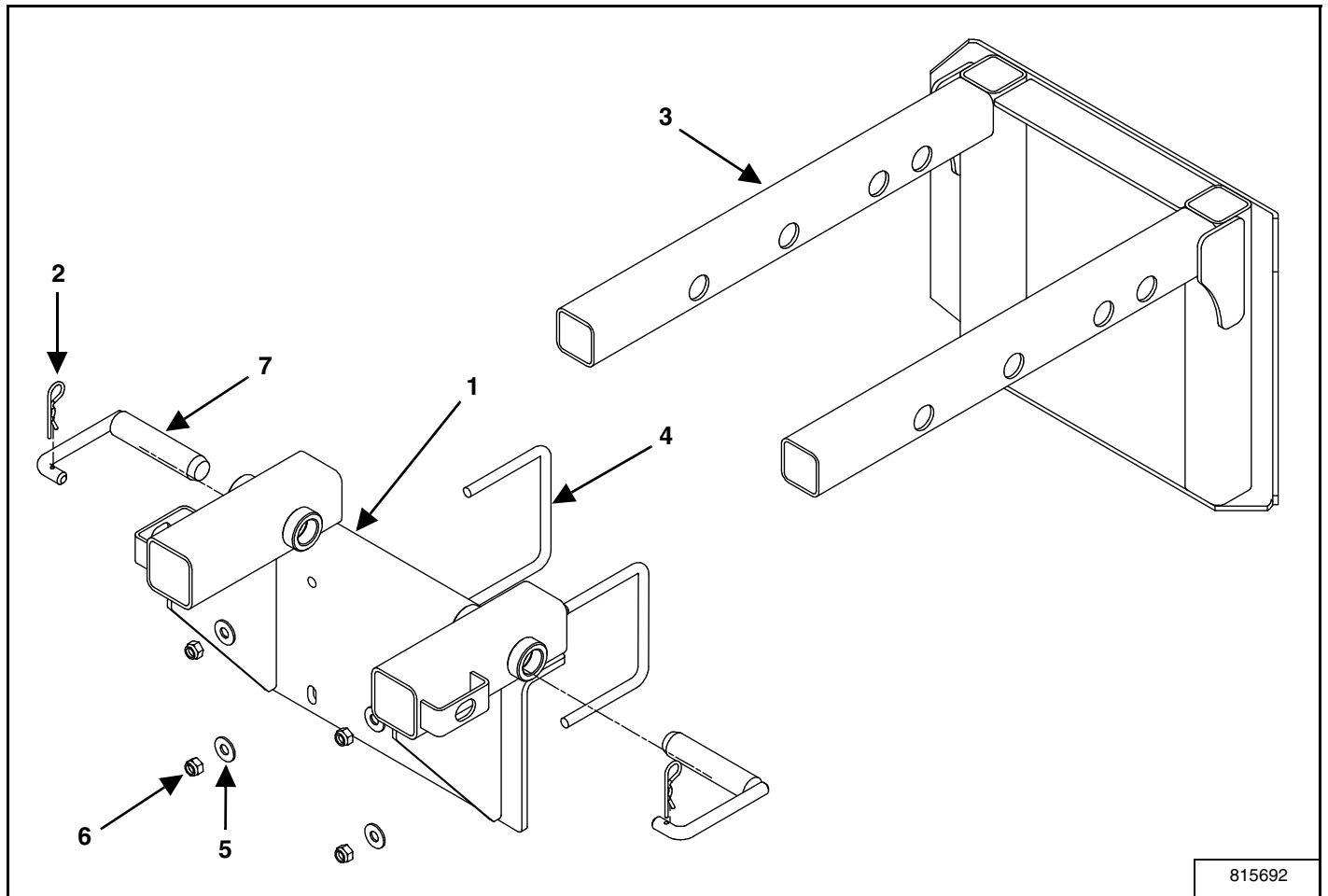

ITEM	PART NUMBER	DESCRIPTION	QTY
1	815693	BALE STOP BRACKET	1
2	12779	HAIRPIN CLIP #9	2
3	815696	BALE STOP WELDMENT	1
4	815416	VALVE MOUNT U-BOLT	2
5	84048	FLAT WASHER, 0.500" SAE BS (PL)	4
6	813663	LOCK NUT, 0.500" NC (STEEL) GR C (PL)	4
7	I20069	BALE STOP LOCKING PIN, 4500	2
NS	815692	COMPLETE BALE STOP ASSEMBLY (Items 1 - 7)	1

**Standard Hitch Assembly**

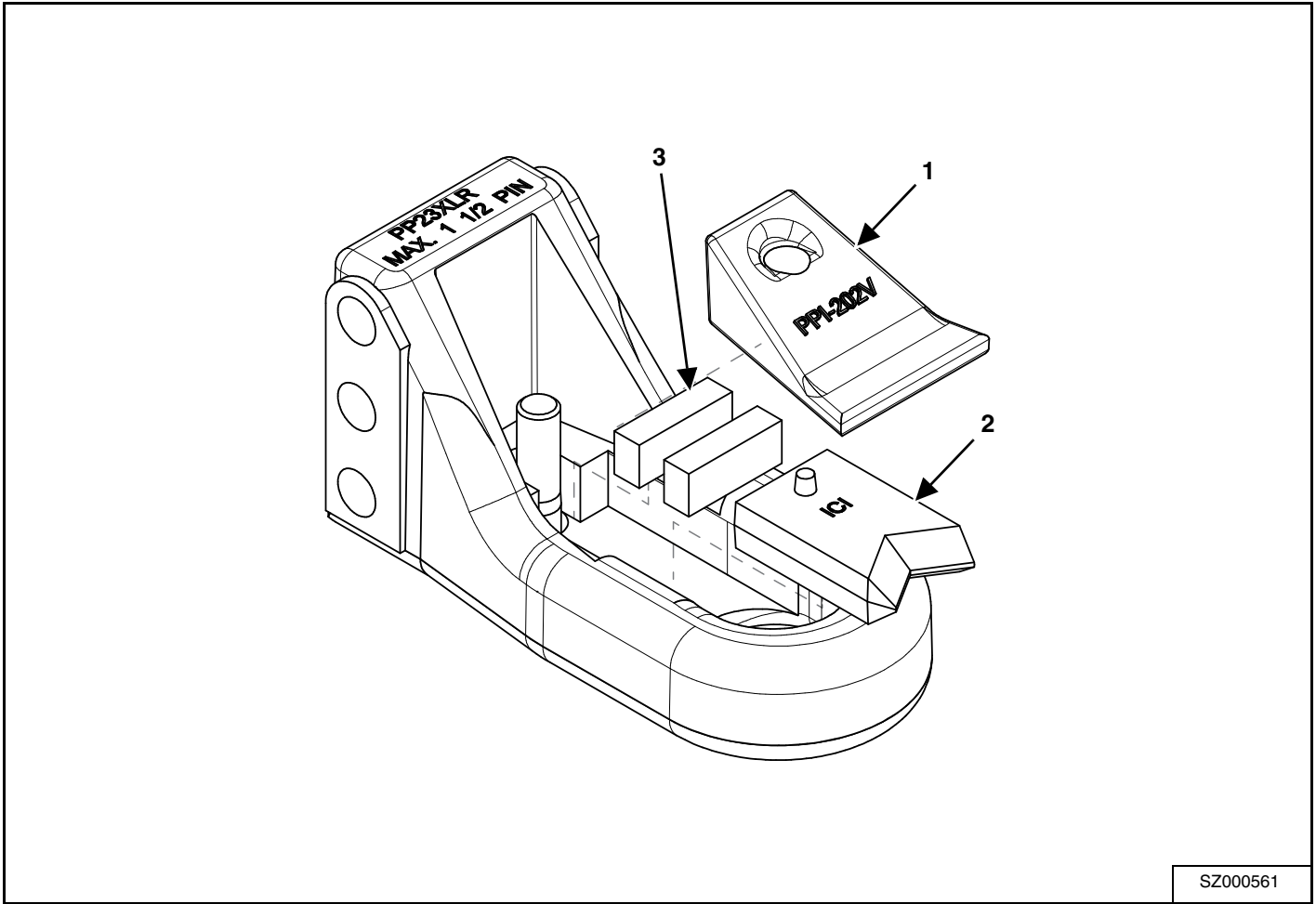

ITEM	PART NUMBER	DESCRIPTION	QTY
1	SZ000569	TOP PLATE	1
2	SZ000570	V-BLOCK	1
3	SZ000571	NEOPRENE CUSHIONS	2

**Optional Clevis Hitch Assembly**

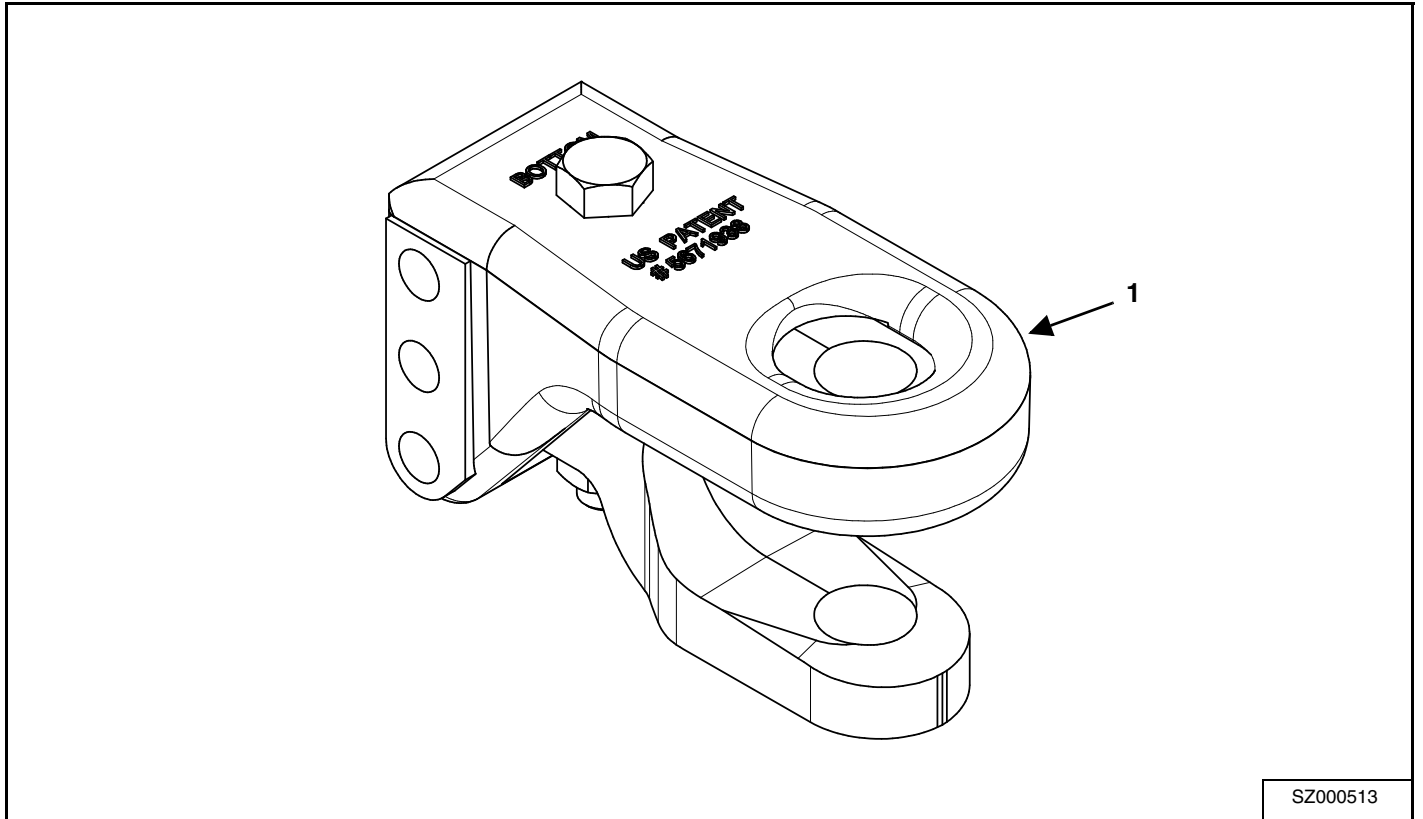

ITEM	PART NUMBER	DESCRIPTION	QTY
1	SZ000513	OPTION CLEVIS HITCH KIT	1

# Farm King



**SPECIFICATIONS**

SPECIFICATIONS .....97  
    Dimensions .....97  
    Performance .....97  
    Load Capacity .....97

HYDRAULIC SCHEMATIC .....98

ELECTRICAL SCHEMATIC .....99  
    Electrical Schematic (Prior to S/N BM240013000061) .....99  
    Electrical Schematic (S/N BM240013000061 and Later) .....100

HARDWARE TORQUE VALUES .....101  
    Metric Chart .....101  
    Imperial Chart .....102

HYDRAULIC CONNECTION SPECIFICATIONS .....103  
    O-Ring Fitting (Straight Thread) .....103  
    O-ring Face Seal Connection .....103  
    Flare Fitting .....103  
    Port Seal (O-ring Boss) Fitting .....103  
    Tubelines And Hoses .....103

# Farm King





**SPECIFICATIONS**

**Dimensions**

DESCRIPTION	2400
Overall Length	34' (10.4 m)
Usable Deck Length	24' (7.3 m)
Maximum Overall Width	22' (6.7 m)
Transport Width	12' 7" (3.8 m)
Overall Height	12' 10" (3.9 m)
Deck Height	3' 7" (1.1 m)
Lift Arm Height (Lift Arm Fully Raised)	12' 10" (3.9 m)

**Performance**

DESCRIPTION	2400
Weight (empty)	7140 lb. (3242 kg) (approx.)
Hitch Weight (empty)	1650 lb (749 kg) (approx.)
Tires	(4) 12.5L x 15FI, Load Range F (Intermittent Unloaded Highway Use)
Tire Capacity	4,680 lb (2,130 kg) @ 90 PSI Inflation
Hubs	6 bolt W / Twine Guard
Maximum Hydraulic Pressure	3000 PSI (20685 kPa)
Minimum Hydraulic Pressure	2250 PSI (15514 kPa)
Hydraulic Motors (Pusher)	Dual 22.2 cu. in.
Lift Cylinder	4" diameter x 12" stroke
Tilt Cylinders	3" diameter x 16" stroke
Electrical	Power: 12v, Fuse: 15 amp

**Load Capacity**

DESCRIPTION	2400
Maximum Load (GVW)	23,140 lb (10,496 kg)
48" (122 cm) Bales	10 Bales (double row on carrier)
60" (152.4 cm) Bales	8 Bales (double row on carrier)

HYDRAULIC SCHEMATIC

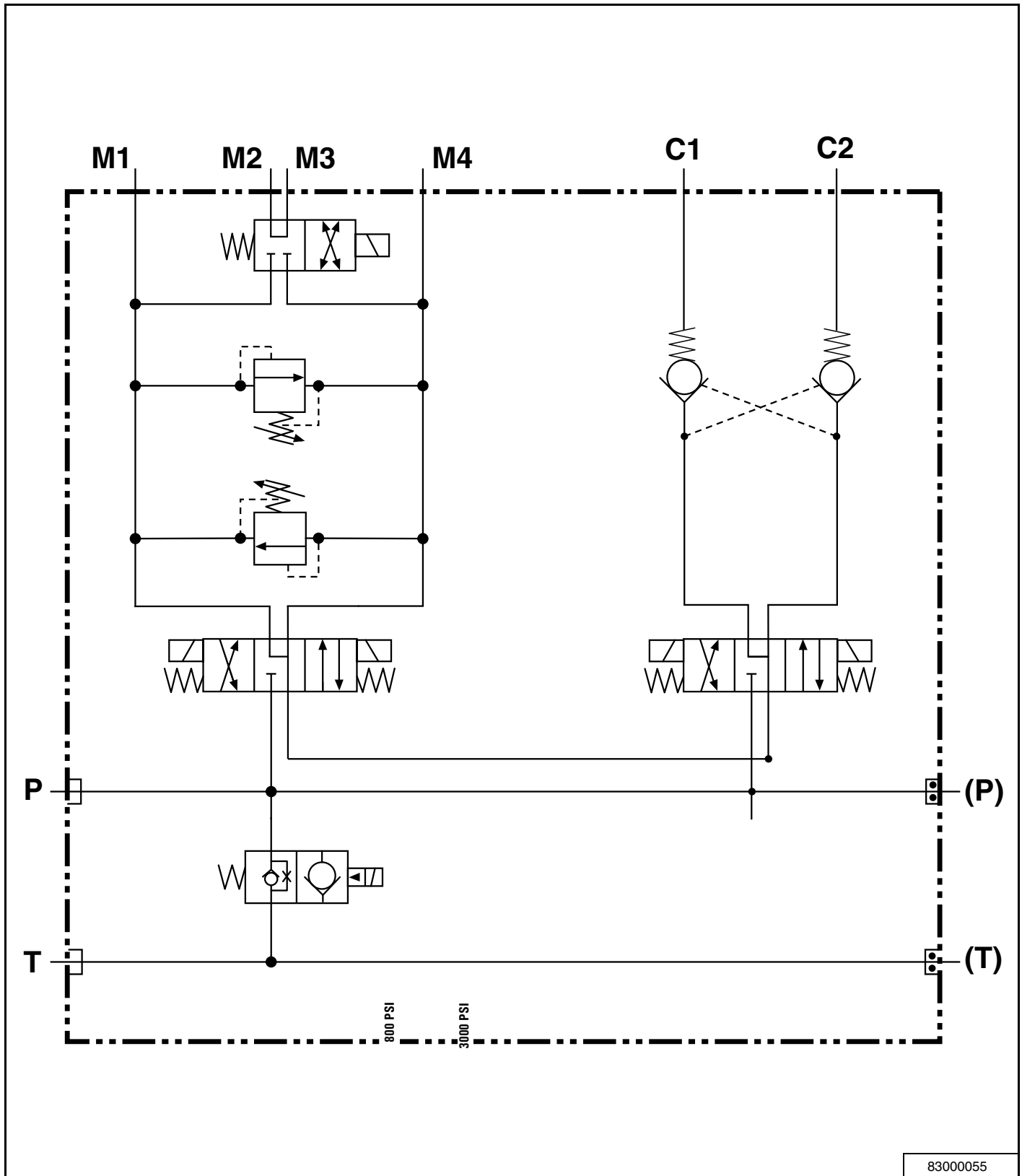

**ELECTRICAL SCHEMATIC**

**Electrical Schematic (Prior to S/N BM240013000061)**

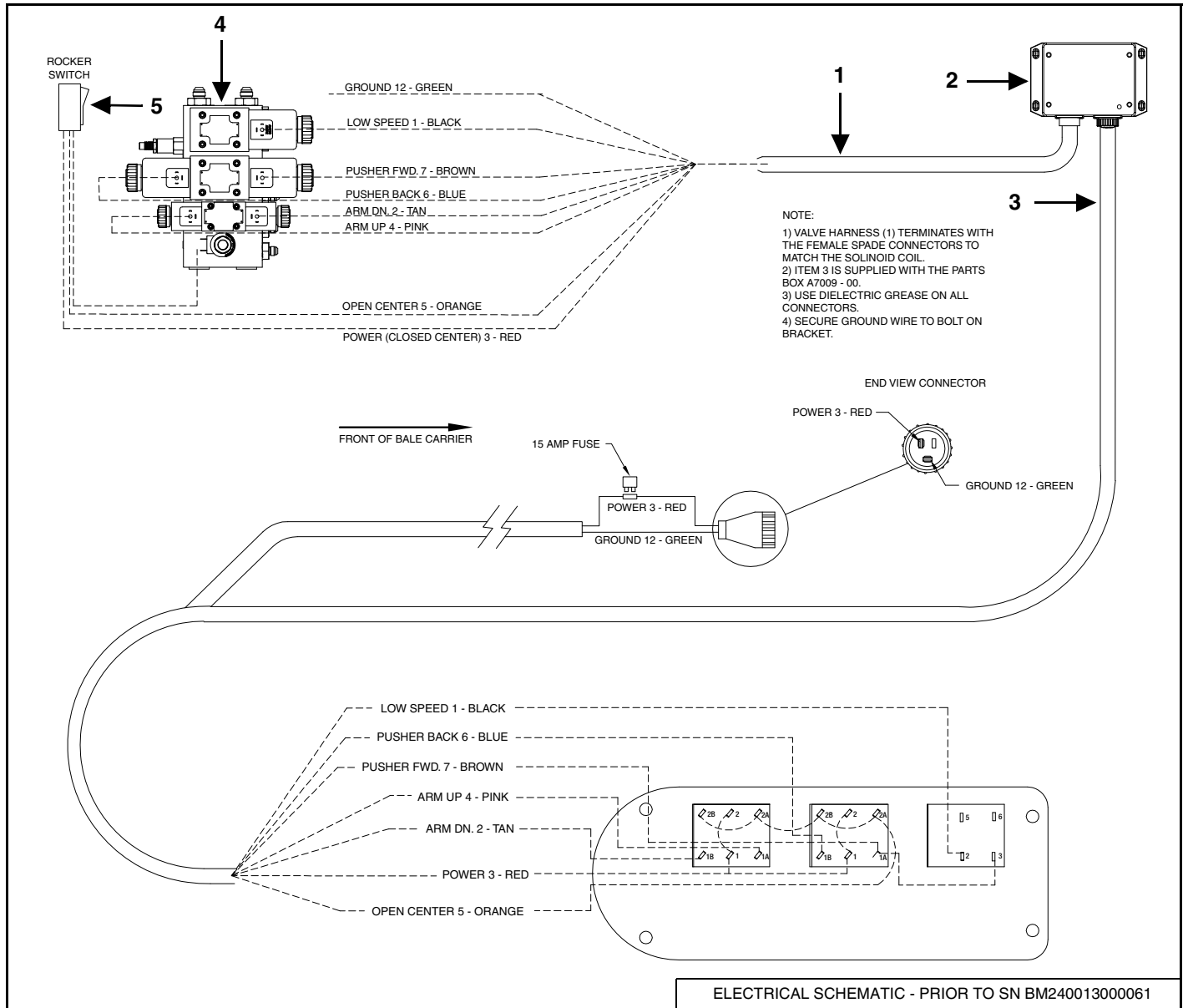

ITEM	PART NUMBER	DESCRIPTION	QTY
1	815620	MACHINE HARNESS 2400	1
2	813949	SNUBBER UNIT	1
3	I20024	CONTROL HANDLE HARNESS ASSEMBLY 2400	1
4	815846	VALVE BANK ASSEMBLY 2400	1
5	SZ000759	OPEN / CLOSED SWITCH	1
<b>OPTIONAL</b>			
-	A4000-00	TRACTOR POWER EXTENSION KIT	1

Electrical Schematic (2018 and later)

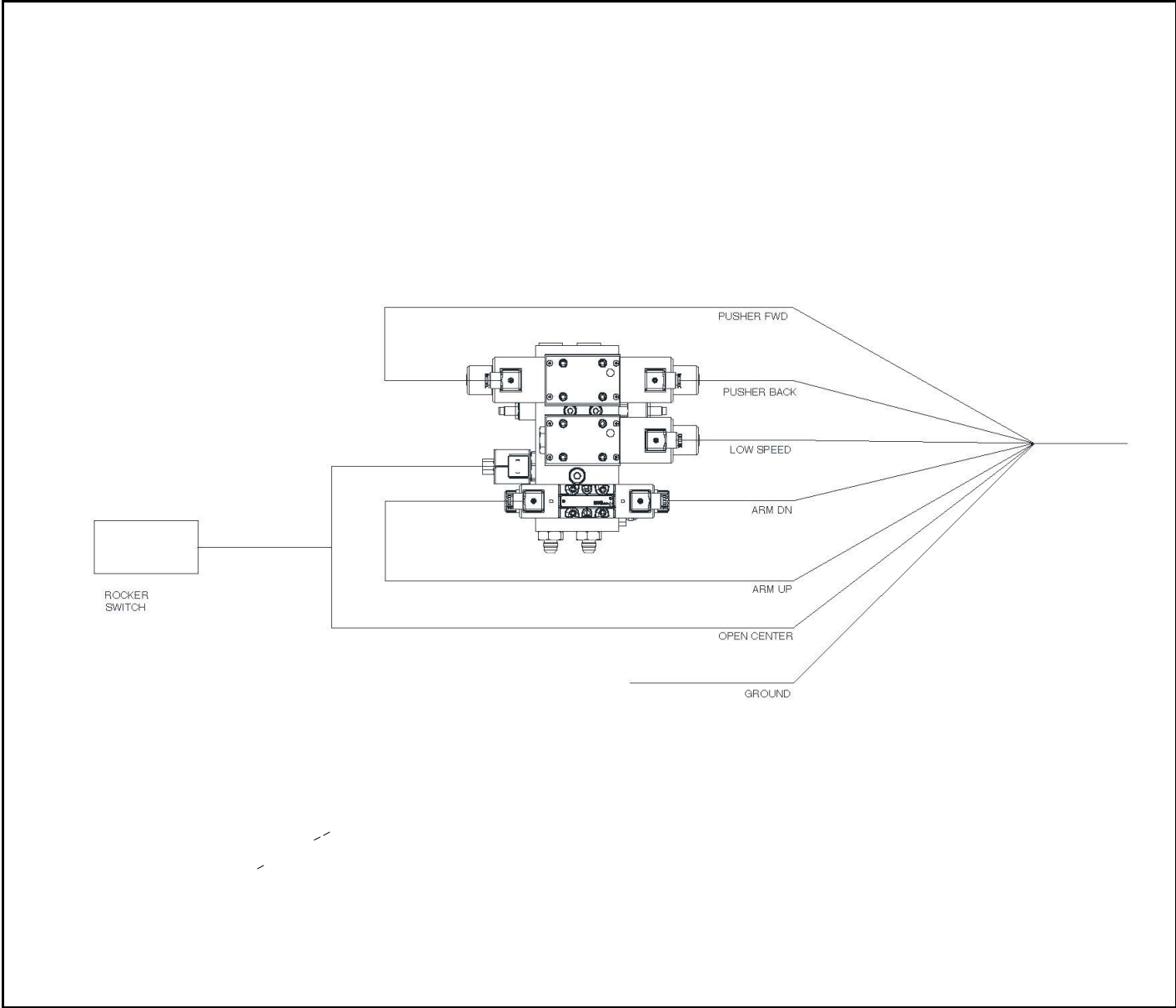

**HARDWARE TORQUE VALUES**

**Metric Chart**

**NOTE: Do not use the values listed in the charts if a different torque value or tightening procedure is specified in this manual for a specific application. Torque values listed are for general use only.**

Use the following charts to determine the correct torque when checking, adjusting or replacing hardware. **Torque values are listed in newton-meters (inch\* or foot pounds) for normal assembly applications.**

Nominal Size	Class 5.8		Class 8.8		Class 10.9		Lock nuts
	Unplated	Plated W / ZnCr	Unplated	Plated W / ZnCr	Unplated	Plated W / ZnCr	CL.8 w/ CL. 8.8 Bolt
M4	1.7 (15*)	2.2 (19*)	2.6 (23*)	3.4 (30*)	3.7 (33*)	4.8 (42*)	1.8 (16*)
M6	5.8 (51*)	7.6 (67*)	8.9 (79*)	12 (102*)	13 (115*)	17 (150*)	6.3 (56*)
M8	14 (124*)	18 (159*)	22 (195*)	28 (248*)	31 (274*)	40 (354*)	15 (133*)
M10	28 (21)	36 (27)	43 (32)	56 (41)	61 (45)	79 (58)	30 (22)
M12	49 (36)	63 (46)	75 (55)	97 (72)	107 (79)	138 (102)	53 (39)
M16	121 (89)	158 (117)	186 (137)	240 (177)	266 (196)	344 (254)	131 (97)
M20	237 (175)	307 (226)	375 (277)	485 (358)	519 (383)	671 (495)	265 (195)
M24	411 (303)	531 (392)	648 (478)	839 (619)	897 (662)	1160 (855)	458 (338)

**NOTE: Torque values shown with \* are inch pounds.**

**Identification of Hex Cap Screws and Carriage Bolts - Classes 5 and up**

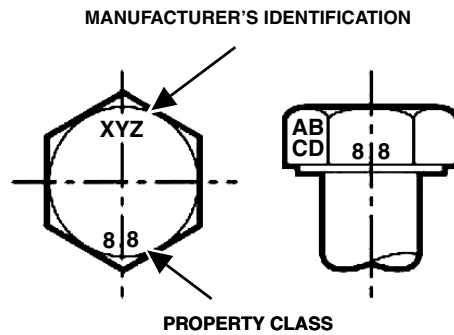

**Identification of Hex Nuts and Lock Nuts - Classes 5 and up**

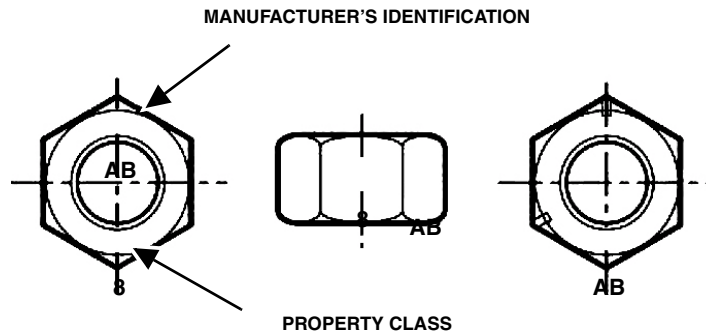

**HARDWARE TORQUE VALUES (CONT'D)**

**Imperial Chart**

**NOTE: Do not use the values listed in the charts if a different torque value or tightening procedure is specified in this manual for a specific application. Torque values listed are for general use only.**

Use the following charts to determine the correct torque when checking, adjusting or replacing hardware. **Torque values are listed in newton-meters (inch\* or foot pounds) for normal assembly applications.**

Nominal Size	SAE Grade 5		SAE Grade 8		LOCK NUTS			
	Unplated or Plated Silver	Plated W / ZnCr Gold	Unplated or Plated Silver	Plated W / ZnCr Gold	Unplated or Plated Silver	Plated W / ZnCr Gold	Grade W / Gr. 5 Bolt	Grade W / Gr. 8 Bolt
1/4	6.2 (55*)	8.1 (72*)	9.7 (86*)	12.6 (112*)	13.6 (121*)	17.7 (157*)	6.9 (61*)	9.8 (86*)
5/16	13 (115*)	17 (149*)	20 (178*)	26 (229*)	28 (250*)	37 (324*)	14 (125*)	20 (176*)
3/8	23 (17)	30 (22)	35 (26)	46 (34)	50 (37)	65 (48)	26 (19)	35 (26)
7/16	37 (27)	47 (35)	57 (42)	73 (54)	80 (59)	104 (77)	41 (30)	57 (42)
1/2	57 (42)	73 (54)	87 (64)	113 (83)	123 (91)	159 (117)	61 (45)	88 (64)
9/16	81 (60)	104 (77)	125 (92)	163 (120)	176 (130)	229 (169)	88 (65)	125 (92)
5/8	112 (83)	145 (107)	174 (128)	224 (165)	244 (180)	316 (233)	122 (90)	172 (127)
3/4	198 (146)	256 (189)	306 (226)	397 (293)	432 (319)	560 (413)	217 (160)	306 (226)
7/8	193 (142)	248 (183)	495 (365)	641 (473)	698 (515)	904 (667)	350 (258)	494 (364)
1	289 (213)	373 (275)	742 (547)	960 (708)	1048 (773)	1356 (1000)	523 (386)	739 (545)

**NOTE: Torque values shown with \* are inch pounds.**

**Identification of Hex Cap Screws and Carriage Bolts**

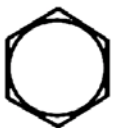

SAE GRADE 2 BOLTS



SAE GRADE 5 BOLTS



SAE GRADE 8 BOLTS



SAE GRADE 2 NUTS



SAE GRADE 5 NUTS



SAE GRADE 8 NUTS

**Identification of Hex Nuts and Lock Nuts**

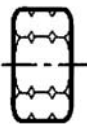

Grade A - No Notches

Grade B - One Circumferential Notch

Grade C - Two Circumferential Notches

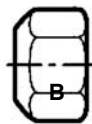

Grade A - No Mark

Grade B - Letter B

Grade C - Letter C

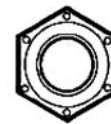

Grade A - No Marks

Grade B - Three Marks

Grade C - Six Marks

(Marks not always located at corners)

**HYDRAULIC CONNECTION SPECIFICATIONS**

**O-Ring Fitting (Straight Thread)**

Lubricate the O-ring before installing the fitting. Loosen the jam nut and install the fitting. Tighten the jam nut until the washer is tight against the surface.

**O-ring Face Seal Connection**

**Figure 54**

O-ring Face Seal Tightening Torque		
Tubeline O.D.	Thread Size	N•m (ft-lb)
1/4"	9/16" - 18	13 (18)
3/8"	11/16" - 16	22 (30)
1/2"	13/16" - 16	40 (54)
5/8"	1" - 14	60 (81)
3/4"	1-3/16" - 12	84 (114)
7/8"	1-3/16" - 12	98 (133)
1"	1-7/16" - 12	118 (160)
1-1/4"	1-11/16" - 12	154 (209)
1-1/2"	2" - 12	163 (221)

When the fitting is tightened, you can feel when the fitting is tight to eliminate leakage caused by under or over torqued fittings. Use petroleum jelly to hold the O-ring in position until the fittings are assembled.

**Flare Fitting**

**Figure 55**

Flare Fitting Tightening Torque		
Tubeline O.D.	Thread Size	N•m (ft-lb)
1/4"	7/16" - 20	13 (18)
5/16"	1/2" - 20	17 (23)
3/8"	9/16" - 18	22 (30)
1/2"	3/4" - 16	40 (54)
5/8"	7/8" - 14	60 (81)
3/4"	1-1/16" - 12	84 (114)
7/8"	1-3/16" - 12	98 (133)
1"	1-5/16" - 12	118 (160)
1-1/4"	1-5/8" - 12	154 (209)
1-1/2"	1-7/8" - 12	163 (221)
2"	2-1/2" - 12	252 (342)

Tighten until the nut makes contact with the seat. Use the chart [Figure 55] to find the correct tightness needed.

**NOTE: If the fitting leaks, disconnect and inspect the seat area for damage.**

**Port Seal (O-ring Boss) Fitting**

**Figure 56**

Port Seal And O-ring Boss Tightening Torque		
Tubeline O.D.	Thread Size	N•m (ft-lb)
1/4"	7/16" - 20	13 (18)
3/8"	9/16" - 18	22 (30)
1/2"	3/4" - 16	40 (54)
5/8"	7/8" - 14	60 (81)
3/4"	1-1/16" - 12	84 (114)
7/8"	1-3/16" - 12	98 (133)
1"	1-5/16" - 12	118 (160)
1-1/8"	1-7/16" - 12	154 (209)
1-1/4"	1-5/8" - 12	163 (221)

**NOTE: Port seal and nut, washer and O-ring (O-ring Boss) fittings use the same tightening torque valve chart.**

If a torque wrench cannot be used, use the following method.

Tighten the nut until it just makes metal to metal contact, you can feel the resistance.

Tighten the nut with a wrench no more than one hex flat maximum.

Do not over tighten the port seal fitting.

**NOTE: If a torque wrench cannot be used, use the hex flat tightening method as an approximate guideline.**

**NOTE: Port seal fittings are not recommended in all applications. Use O-ring boss fittings in these applications.**

**Tubelines And Hoses**

Replace any tubelines that are bent or flattened. They will restrict flow, which will slow hydraulic action and cause heat.

Replace hoses which show signs of wear, damage or weather cracked rubber.

Always use two wrenches when loosening and tightening hose or tubeline fittings.

# Farm King





**WARRANTY**

WARRANTY .....107

# Farm King



**WARRANTY**

# **Farm King**

## **Limited Warranty**

**BASE LIMITED WARRANTY**

Farm King provides this warranty only to original retail purchasers of its products. Farm King warrants to such purchasers that all Farm King manufactured parts and components used and serviced as provided for in the Operator's Manual shall be free from defects in materials and workmanship for a period following delivery to the original retail purchaser of one (1) year. This limited warranty applies only to those parts and components manufactured by Farm King. Parts and components manufactured by others are subject to their manufacturer's warranties, if any.

Farm King will fulfill this limited warranty by, at its option, repairing or replacing any covered part that is defective or is the result of improper workmanship, provided that the part is returned to Farm King within thirty (30) days of the date that such defect or improper workmanship is, or should have been, discovered. Parts must be returned through the selling representative and the buyer must prepay transportation charges.

Farm King will not be responsible for repairs or replacements that are necessitated, in whole or part, by the use of parts not manufactured by or obtained from Farm King. Under no circumstances are component parts warranted against normal wear and tear. There is no warranty on product pump seals, product pump bearings, rubber product hoses, pressure gauges, or other components that require replacement as part of normal maintenance.

**REPAIR PARTS LIMITED WARRANTY**

Farm King warrants genuine Farm King replacement parts purchased after the expiration of the Farm King Limited Warranty, and used and serviced as provided for in the Operator's Manual, to be free from defects in materials or workmanship for a period of thirty (30) days from the invoice date for the parts. Farm King will fulfill this limited warranty by, at its option, repairing or replacing any covered part that is defective or is the result of improper workmanship, provided that the part is returned to Farm King within thirty (30) days of the date that such defect or improper workmanship is, or should have been, discovered. Such parts must be shipped to the Farm King factory at the purchaser's expense.

**WHAT IS NOT COVERED**

Under no circumstances does this limited warranty cover any components or parts that have been subject to the following: negligence; alteration or modification not approved by Farm King; misuse; improper storage; lack of reasonable and proper maintenance, service, or repair; normal wear; damage from failure to follow operating instructions; accident; and/or repairs that have been made with parts other than those manufactured, supplied, and / or authorized by Farm King.

**AUTHORIZED DEALER AND LABOR COSTS**

Repairs eligible for labor under this limited warranty must be made by Farm King or an authorized Farm King dealer. Farm King retains the exclusive discretion to determine whether it will pay labor costs for warranty repairs or replacements, and the amount of such costs that it will pay and the time in which the repairs will be made. If Farm King determines that it will pay labor costs for warranty work, it will do so by issuing a credit to the dealer's or distributor's account. Farm King will not approve or pay invoices sent for repairs that Farm King has not previously approved. Warranty service does not extend the original term of this limited warranty.

# Farm King

## Limited Warranty

### WARRANTY REQUIREMENTS

To be covered by warranty, each new product must be registered with Farm King within thirty (30) days of delivery to original retail purchaser. If the customer decides to purchase replacement components before the warranty disposition of such components is determined, Farm King will bill the customer for such components and then credit the replacement invoice for those components later determined to be covered by this limited warranty. Any such replacement components that are determined not be covered by this limited warranty will be subject to the terms of the invoice and shall be paid for by the purchaser.

### EXCLUSIVE EFFECT OF WARRANTY AND LIMITATION OF LIABILITY

TO THE EXTENT PERMITTED BY LAW, FARM KING DISCLAIMS ANY WARRANTIES, REPRESENTATIONS, OR PROMISES, EXPRESS OR IMPLIED, AS TO THE QUALITY, PERFORMANCE, OR FREEDOM FROM DEFECT OF THE COMPONENTS AND PARTS COVERED BY THIS WARRANTY AND NOT SPECIFICALLY PROVIDED FOR HEREIN.

TO THE EXTENT PERMITTED BY LAW, FARM KING DISCLAIMS ANY IMPLIED WARRANTIES OF MERCHANTABILITY AND FITNESS FOR A PARTICULAR PURPOSE ON ITS PRODUCTS COVERED HEREIN, AND DISCLAIMS ANY RELIANCE BY THE PURCHASER ON FARM KING'S SKILL OR JUDGMENT TO SELECT OR FURNISH GOODS FOR ANY PARTICULAR PURPOSE. THE PURCHASER'S ONLY AND EXCLUSIVE REMEDIES IN CONNECTION WITH THE BREACH OR PERFORMANCE OF ANY WARRANTY ON FARM KING'S PRODUCTS ARE THOSE SET FORTH HEREIN. IN NO EVENT SHALL FARM KING BE LIABLE FOR INCIDENTAL OR CONSEQUENTIAL DAMAGES (INCLUDING, BY WAY OF EXAMPLE ONLY AND NOT LIMITATION, LOSS OF CROPS, LOSS OF PROFITS OR REVENUE, OTHER COMMERCIAL LOSSES, INCONVENIENCE, OR COST OF REPLACEMENT OF RENTAL EQUIPMENT). IN NO EVENT SHALL FARM KING'S CONTRACT OR WARRANTY LIABILITY EXCEED THE PURCHASE PRICE OF THE PRODUCT. (Note that some states do not allow limitations on how long an implied warranty lasts or the exclusion or limitation of incidental or consequential damages, so the above limitations and exclusion may not apply to you.) This warranty gives you specific legal rights and you may also have other rights, which vary from state to state.

Farm King neither assumes nor authorizes any person or entity, including its selling representatives, to assume any other obligations or liability in connections with the sale of covered equipment, or to make any other warranties, representations, or promises, express or implied, as to the quality, performance, or freedom from defect of the components and parts covered herein. No one is authorized to alter, modify, or enlarge this limited warranty, or its exclusions, limitations and reservations.

Corrections of defects and improper workmanship in the manner, and for the applicable time periods, provided for herein shall constitute fulfillment of all responsibilities of Farm King to the purchaser, and Farm King shall not be liable in negligence, contract, or on any other basis with respect to the subject equipment.

This limited warranty is subject to any existing conditions of supply which may directly affect Farm King's ability to obtain materials or manufacturer replacement parts.

Buhler Industries Inc. reserves the right to make improvements in design or changes in specifications to its products at anytime, without incurring any obligation to owners of units previously sold.

**ALPHABETICAL INDEX**

AXLE .....	58
BALE STORAGE .....	60
BASE FRAME .....	63
BASE GROUP .....	24
CARRIER BEAMS .....	59
CLEANING THE BALE CARRIER .....	59
ELECTRICAL SCHEMATIC .....	99
EQUIPMENT DECALS AND SIGNS .....	19
EQUIPMENT IDENTIFICATION .....	10
FIRE PREVENTION .....	15
GENERAL ASSEMBLY INFORMATION ...	23
GENERAL INFORMATION .....	35
GENERAL INFORMATION .....	63
HARDWARE TORQUE VALUES .....	101
HYDRAULIC CONNECTION SPECIFICATIONS .....	103
HYDRAULIC SCHEMATIC .....	98
INITIAL SET-UP .....	38
LUBRICATION .....	53
OWNER'S INFORMATION .....	9
PUSHER CHAIN AND SPROCKET .....	55
SAFETY INSTRUCTIONS .....	13
SAFETY SIGN (DECAL) INSTALLATION ..	59
SAFETY SIGN-OFF FORM .....	20
SAFETY SIGNS (DECALS) .....	17
SERVICE SCHEDULE .....	52
SPECIFICATIONS .....	97
STORAGE AND RETURN TO SERVICE ...	60
TRANSPORTING .....	47
TROUBLESHOOTING .....	51
WARRANTY REGISTRATION FORM .....	5
WARRANTY .....	107

# Farm King





[www.farm-king.com](http://www.farm-king.com)

# Farm King

411 Center Avenue West  
Salem, SD USA 57058-0398  
Toll Free: 1-888-FK-80001  
E-mail: [info@buhler.com](mailto:info@buhler.com)  
[www.farm-king.com](http://www.farm-king.com)

Equipment shown is subject to change without notice.  
©2012 Buhler Trading Inc. Printed in Canada TSX:BUI

**bühler** | a division of Buhler Industries Inc.