



OSL Series Disc Harrow

Quick Hitch Ready

For use with these starting serial numbers:

Model	Serial Number
OSL600	OS6Cxxx
OSL750	OS7Cxxx
OSL900	OS9Cxxx

ATTENTION:
ALL WARRANTY WORK MUST BE APPROVED
BY BROWN MFG. CORP.

BEFORE WORK BEGINS

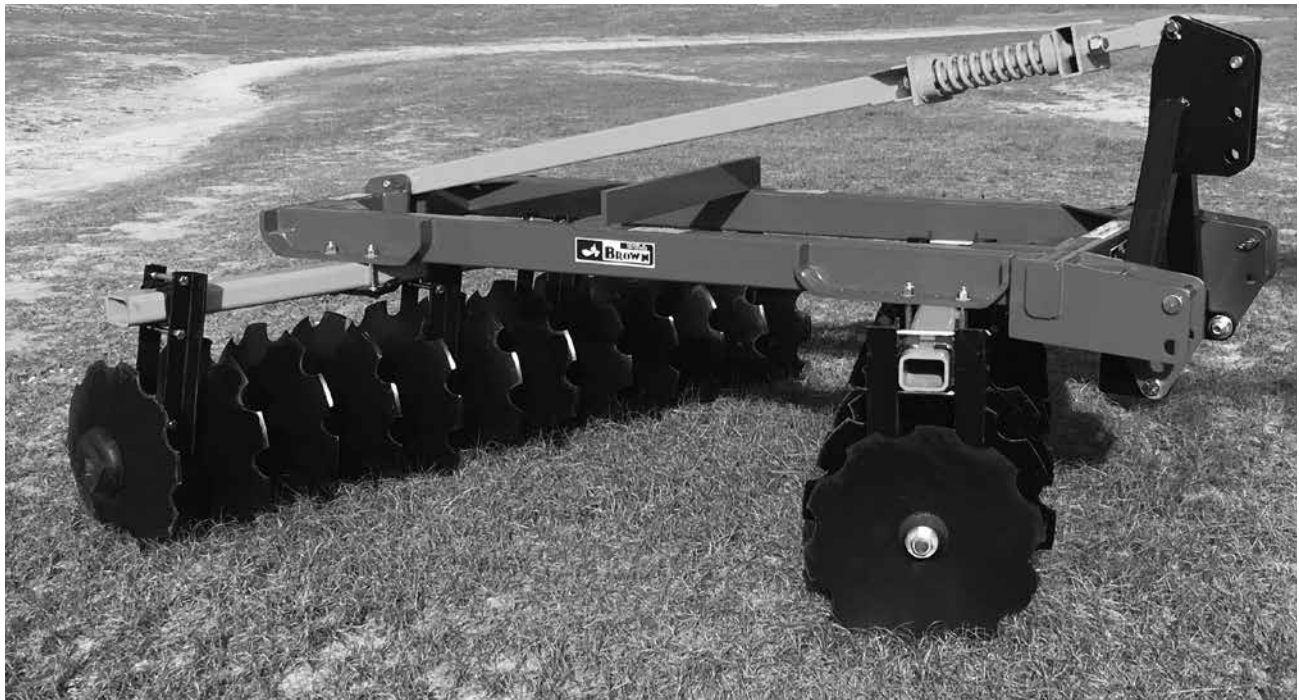

NOTE: When attaching implement to tractor with a **Quick Hitch**, ALL pins **MUST** be CAT III pins, both upper pin and lower pins, regardless of hitch category.

Owner / Operator Manual



HEAVY DUTY SINCE 1944

6001 E. Hwy 27 - Ozark, AL 36360
334.795.6603 - Fax: 334.795.3029

www.brownmfgcorp.com

⚠ WARNING



Before operating your machine, stop and read this owners manual. Do not attempt to operate the unit until you fully understand the material covered in this manual. Without the knowledge contained in this manual, injury or death can result.

Copyright

Copyright ©2000 Brown Manufacturing Corporation. All photos and illustrations are property of Brown Manufacturing Corporation. This publication may be freely reproduced, either in whole or in part, provided that the content herein is not altered.

Cover

Pictured: Model OSL-900-2422 disc harrow.

Disclaimer

Due to engineering improvements and revision of product specifications, the information contained in this manual is subject to change without notice.

Contents

Warranty.....	4
Registration.....	5
Equipment Safety.....	7
Assembly.....	12
Operation.....	14
Troubleshooting.....	15
Specifications.....	15
Replacement Parts.....	16

Warranty Statement

LIMITED WARRANTY

BROWN MANUFACTURING CORP. hereby warrants that Brown's products will be free from defects in material and workmanship under normal use according to the provisions and limitations herein set forth. All parts, specifically EXCLUDING expendable 'wear' parts, that become unserviceable, due to defective material or workmanship, within twelve months / 365 days from date of the original retail purchase, shall, at Brown's option, be repaired or replaced.

LIMITATIONS

The obligations of Brown for breach of warranty shall be limited to products manufactured by Brown; (1) that are installed, operated, and maintained according to Brown's instruction furnished and/or available to the purchaser upon request; (2) that are installed according to all other applicable Federal, State, and local codes or regulations; and (3) that the purchaser substantiates were defective in material and workmanship notwithstanding that they were properly installed and correctly maintained as set forth and were not abused or misused. The obligation of Brown shall be limited to replacing or repairing the defective product, at the option of Brown. Brown shall not be responsible for any labor or cost of removal or repairing or reinstallation of its products and shall not be liable for transportation costs to and from its plant in Ozark, Alabama. Use of parts for modification or repair of the product or any component part thereof not authorized or manufactured by Brown specifically for such product shall void this warranty. This warranty shall not apply to any damage to or defect in the Brown's products that is directly or indirectly caused by; (1) FORCE MAJEURE, act of GOD, or other accident not related to an inherent product defect; or (2) abuse, misuse, or neglect of the such product, including any damage caused by improper assembly, installation, adjustment, or faulty instruction of the purchaser. **OTHER THAN AS EXPRESSLY SET FORTH HEREINABOVE, BROWN MAKES NO OTHER WARRANTY, EXPRESS OR IMPLIED, WITH RESPECT TO ANY OF BROWN'S PRODUCTS, INCLUDED BUT NOT LIMITED TO ANY MERCHANTABILITY OR FITNESS FOR A PARTICULAR PURPOSE. IN NO EVENT SHALL BROWN BE RESPONSIBLE FOR ANY INCIDENTAL OR CONSEQUENTIAL DAMAGES OF ANY NATURE SUFFERED BY PURCHASER OR ANY OTHER PERSON OR ENTITY CAUSED IN WHOLE OR IN PART BY ANY OF BROWN'S PRODUCTS.** Any person or entity to whom this warranty extends and who claims breach of warranty against Brown must bring suit thereon within one year from the date of occurrence of such breach of warranty or be forever barred from any and all legal or other remedies for such breach of warranty. Brown is not responsible for and hereby disclaims any undertaking, representation, or warranty made by any dealer, distributor, or other person that is inconsistent with or in any way more expensive than the provisions of this limited warranty. This warranty grants specific legal rights and shall be read in conformity with applicable state law. In some jurisdictions, the applicable law mandates warranty provisions that provide greater rights than those provided for herein. In such case, this limited warranty shall be read to include such mandates provisions; and any provision herein that is prohibited or unenforceable in any such jurisdiction shall, as to such jurisdiction, be ineffective to the extent of such prohibition or unenforceable without invalidating the remaining provisions and without affecting the validity or enforceability of such provisions in any other jurisdiction.

STATEMENT OF POLICY

In accordance with our established policy of constant improvement, we reserve the right to amend these specifications at any time without notice.

WARRANTY BY MANUFACTURER

Dealer/distributor understands and agrees that the manufacturer extends only the following warranty to its customers. In the event dealer/distributor extends any additional warranty such as enlarging the scope or period of warranty or undertaking a warranty of fitness for any particular purpose or obligation not encompassed in manufacturer's warranty, dealer/distributor shall be solely responsible therefore and shall have no recourse against manufacturer with respect thereto.

Owner Registration

To place the manufacturer's warranty into effect, the registration card below must be mailed within thirty (30) days after receiving equipment. The model number and serial number is located in front of the manual holder tube.

Owner Registration



Important: To place the manufacturer's warranty into effect, the card must be mailed within thirty (30) days after receiving equipment.

Model: OSL- _____

Serial No.: _____

For further information:
Brown Manufacturing Corp.
6001 East Hwy 27
Ozark, AL 36360

Date Purchased: ___/___/___

Phone: (334) 795-6603
Toll Free: (800) 663-8909
FAX: (334) 795-3029

Dealer: _____

www.brownmfgcorp.com
brown@brownmfgcorp.com

Owner Registration



Important: To place the manufacturer's warranty into effect, this card must be mailed within thirty (30) days after receiving equipment.

Name: _____

Address: _____

City: _____ State: _____

Model: OSL- _____

Serial No.: _____

Return to:
Brown Manufacturing Corp.
6001 East Hwy 27
Ozark, AL 36360

Date Purchased: ___/___/___



Dealer: _____

Please use envelope.

Equipment Safety

Warning: Read this manual before operation.

Operators of the equipment must read and understand this manual. Failure to read this manual and follow these safety and operating instructions could result in serious bodily injury or even death.

 WARNING	
	<p>Before operating your machine, stop and read this owners manual. Do not attempt to operate the unit until you fully understand the material covered in this manual. Without the knowledge contained in this manual, injury or death can result.</p>

Equipment Safety

Recognize safety information

This is the safety alert symbol. When you see this symbol on your equipment or in this manual, be alert to the potential for personal injury or injury to others.



Understand signal words

DANGER indicates an imminently hazardous situation which, if not avoided, will result in death or serious injury



WARNING indicates a hazardous situation which, if not avoided, could result in serious injury or death.



CAUTION indicates a potentially hazardous situation which, if not avoided, may result in minor or moderate injury.



NOTICE indicates information considered important but not directly hazard related. (e.g. security, hygiene, equipment or property damage).



Follow safety instructions

- Read owner/operator manual.
- Replace missing or damaged safety decals.
- Safety decals and this manual must be considered a permanent part of your equipment.
- Should ownership of the equipment be transferred, this manual must also be transferred.
- Unauthorized modifications to the equipment are not recommended. This could impair the function, safety, and life of the machine.
- For any part of this manual that you do not understand, contact your dealer or Brown Manufacturing Corporation at (800) 633-8909.
- All implements with moving parts are potentially dangerous. Due to this fact, there is no substitute for a safe, knowledgeable operator. It is important that all persons operating this equipment read, understand, and follow the instructions provided in this manual.





DO NOT OPERATE THIS UNIT IF YOU ARE UNDER THE INFLUENCE OF ALCOHOL, ILLEGAL DRUGS, OR ANY PRESCRIPTION OR OVER THE COUNTER MEDICATIONS THAT COULD CAUSE DROWSINESS, DIZZINESS, DISORIENTATION AND/OR IMPAIR YOUR ABILITY IN ANY WAY TO SAFELY OPERATE THE UNIT.

DO NOT OPERATE THIS UNIT IF YOU SUFFER FROM ANY PHYSICAL CONDITION OR DISABILITY THAT WOULD IMPAIR YOUR ABILITY TO OPERATE IT SAFELY.





Equipment Safety

Safety Decals

The following safety decals should be attached to the equipment at all times. Should any decal become damaged or lost, it is the responsibility of the owner to replace it. Additional decals may be obtained from the manufacturer.

 WARNING	 ADVERTENCIA
	<p>Antes de probar la unidad por primera vez deben remitirse a las instrucciones contenidas en el manual.</p>
<p>Read and understand owner's manual before operating unit.</p>	 ADVERTISSEMENT <p>S'assurer de bien comprendre toutes les consignes du manuel de propriétaire avant d'utiliser la unité.</p>

Part No.: SD-010.

 DANGER	 PELIGRO
	<p>CUCHILLAS ROTATIVAS</p> <ul style="list-style-type: none"> •Guarden las monas y los pies lejos de las cuchillas. •No se acerquen a la máquina estando funcionando el motor.
<p>ROTATING BLADES</p> <ul style="list-style-type: none"> •Keep hands and feet away from blades. •Stay away from machine when engine running. 	 DANGER <p>LAMES ROTATIVES</p> <ul style="list-style-type: none"> •Garder les mains et les pieds éloignés des lames rotatives. •Rester loin de la machine quand le moteur tourne.

Part No.: SD-012A.

Equipment Safety

Warning! Transport with care.

Before transporting to a new location, make certain that the slow-moving vehicle (SMV) emblem is installed and is clearly visible. Use flashing lights and follow local traffic regulations.

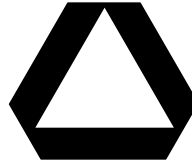

WARNING

Transport with care. Use slow-moving vehicle emblem and flashing light. Follow local traffic regulations.

Danger! Protect bystanders, clear work area of debris.

Do not operate the cutter near people. Debris can be thrown hundreds of feet. Clear work area of foreign objects such as wire, glass, and other debris. Debris thrown by the cutter can cause serious injury or death.

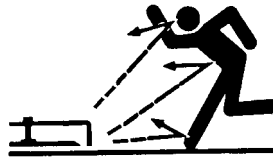

DANGER

Do not operate cutter near bystanders. Clear work area of debris before operating.

Warning! Parking and dismounting.

The rotating parts of this cutter continue to rotate even after the PTO has been disengaged. The operator should remain seated until rotation has stopped. He should then set the brake, turn off the engine, and remove the key. See tractor manual for proper parking procedure.



WARNING

Wait for all rotation to stop before dismounting tractor.

Caution! Avoid fires.

Keep the machine clean of debris, trash, and any other flammable material.



CAUTION

Keep machine clean of debris. Flammable debris on machine poses fire hazard.

 **Warning!**
Fasten Seatbelt!
Before Starting Tractor!
Always Wear Your Seatbelt.

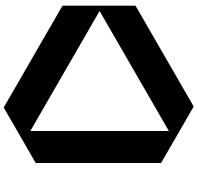

Equipment Safety

	⚠️WARNING
	Transport with care. Use slow-moving vehicle emblem and flashing light. Follow local traffic regulations.

Warning! Transport with care. Before transporting to a new location, make certain that the slow-moving vehicle emblem is installed and is clearly visible. Use flashing lights and follow local traffic regulations.

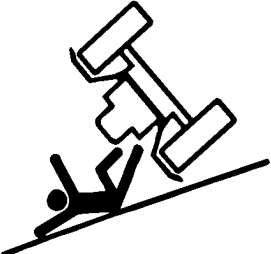
	⚠️WARNING
	Use only with tractors equipped with a certified roll-over protection system.

Warning! Roll-over protection. Do not operate the harrow on any tractor not equipped with a certified roll-over protection system.

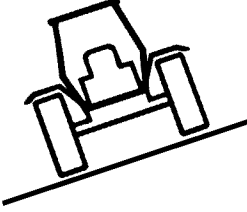
	⚠️WARNING
	Slow travel speed when operating on slopes or rough terrain.

Warning! Slopes and rough terrain. When operating on slopes or rough terrain, slow travel speed. Do not operate in an area where the tractor could roll over. **Be sure to fasten safety belt when operating tractor!**

Assembly

Optional Blade Scraper Assembly Instructions

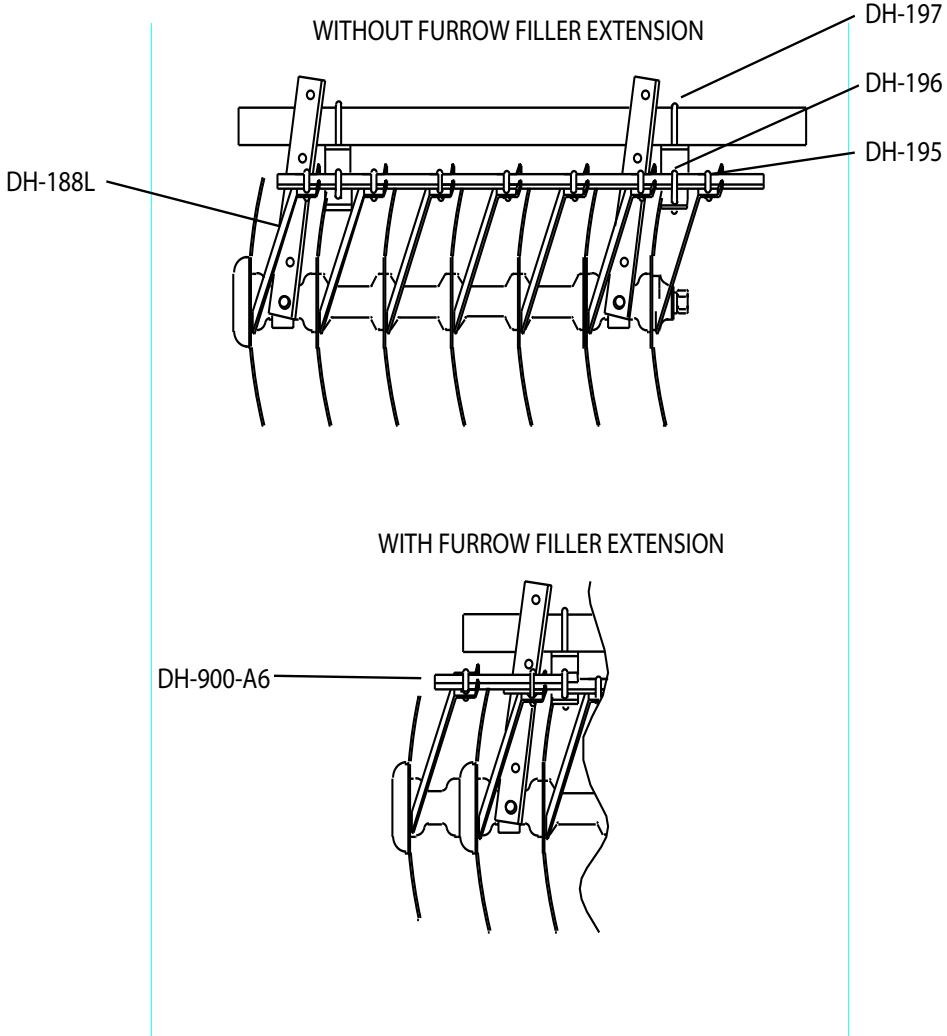

Bearing Replacement

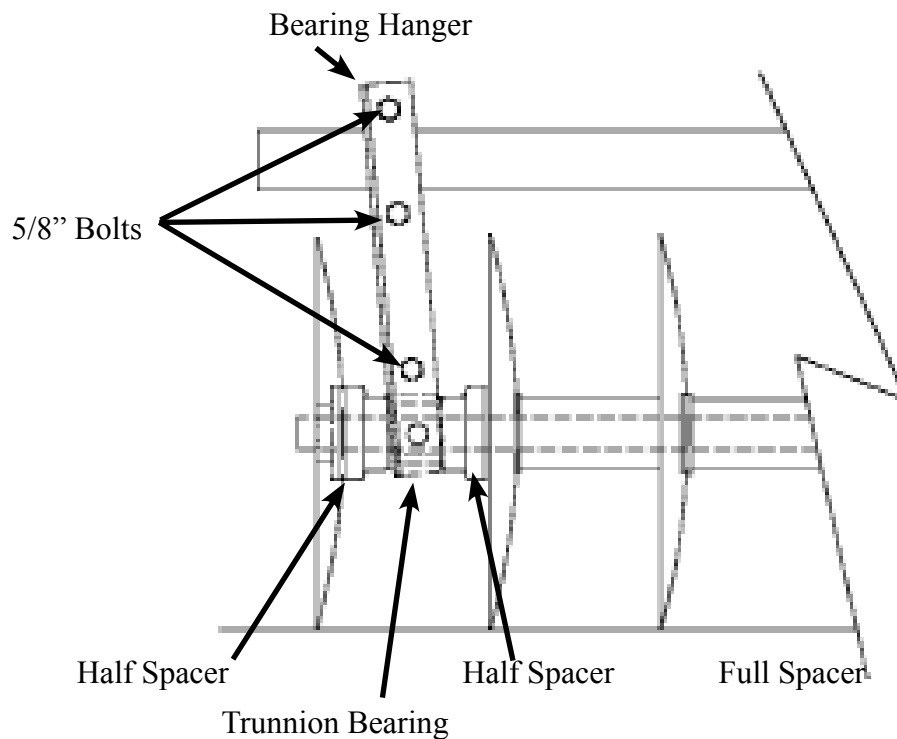

- 1- Attach the tractor to the disc harrow
- 2- Loosen the axle nut while the axle is still attached to the frame – but do not remove.
- 3- Remove the 5/8" bolts from the bearing hanger that attach the axle to the gang arm. There are 3 bolts on each bearing hanger.
- 4- Once the two bearing hangers are removed from the axle, lift the disc harrow frame with your tractor and move the unit away from the axle assembly.
- 5- Stand the axle assembly up with the axle nut on top, secure the axle assembly in the standing position in a manner that it cannot fall over.
- 6- Remove axle nut from the axle and unstack the assembly down to the bearing that you wish to replace – Note the order and the position of the components as you remove them. This will insure the proper order for reassembling the axle. Clean all components.
- 7- With new bearing assembly replaced on the axle restack all the components back onto the axle, in the same order as they were removed.
- 8- Start the axle nut onto the axle – but do not torque it at this time
- 9- Lay axle assembly back down on the ground and back the harrow frame over the axle assembly. Lower the frame down to the axle and remount the bearing hanger to the axle assembly.
- 10- Torque the axle nut, to a minimum of 400 to 500 foot Lbs. of torque, its very important that axle nut is tight – and must be rechecked after the first hour of operation.

Operation



Before hitching harrow to your tractor, make sure all safety devices are installed on the tractor. Please follow all safety instructions and procedures.

NOTE: When attaching implement to tractor with a **Quick Hitch**, **ALL** pins **MUST** be **CAT III pins**, both upper pin and lower pins, regardless of hitch category.

Attach equipment to tractor.

Be sure the tractor is equipped with the correct category hitch pins, top link, etc.

Be extremely careful when positioning tractor to hitch to the equipment.

Caution! Never allow anyone between the tractor and the equipment during the hitching process.

Adjust cutting depth.

Be sure the tractor engine is off, key is removed, and all movement of the tractor has stopped before dismounting to make adjustments.

Using the center link adjustment and the lift arms of the tractor, set the equipment so that the front and rear gangs are cutting at the same depth. The left-to-right pitch is obtained by adjusting the lift lengths. Set the lift stop at the required position to maintain a uniform depth.

When cutting, the frame should be parallel to the ground. Extend tractor top link to add pressure to rear gang.

Operating speed

Proper operating speed for equipment will depend upon the soil conditions and the particular application.



Warning! Avoid personal injury. Never allow anyone to ride on the tractor or harrow.

Remember: The safe operation of this equipment is the responsibility of the operator. The operator should be familiar with both the tractor and the equipment. The operator should read and understand all applicable operator manuals and follow all safety practices.

General Information

Specifications

Model	No./Dia. Blades	Spacing	Width Cut	Weight	No. Bearings	Horse power Required
OSL-600-1622	16/22	9/9	6'4"	1310 Lbs.	8	60
OSL-750-2022	20/22	9/9	7'6"	1455 Lbs.	8	70
OSL-900-2422	24/22	9/9	9'1"	1830 Lbs.	8	90

Standard Features

3" x 5" High Tensile Steel Tube Frame

Adjustable 3" x 4" Gang Arm

Triple-Sealed Ball Bearing

Self-Aligning Bearing Housing

1-1/8" Forged Square Axle

Cast Iron Spacers

22" Notched 7 Ga. Blades

Weight Rack

Cat. II Clevis Hitch

Dual Spring Loaded A-Frame Brace

Quick Hitch Compatible

Optional Equipment

Options	Part No.
Scraper (need one per blade)	DH-188A
Furrow Filler adapter	DH-122A

Troubleshooting

Problem	Possible Cause(s)	Possible Solution(s)
Blades Penetration	<ol style="list-style-type: none"> 1. Hard or Dry Ground 2. Gang Arm Angle 3. Improper Tractor Lift / Draft 	<ol style="list-style-type: none"> 1. Add Additional Weight 2. Reduce / Increase Gang Arm Angle 3. Check Tractor Lift / Draft
Side Draft / Pulling To Side	<ol style="list-style-type: none"> 1. Lift Arms Are Not Matched 2. Unequal Rear Tire Pressure 	<ol style="list-style-type: none"> 1. Match Lift Arm Lengths 2. Check Tire Pressure
Rear Blades Not Cutting	<ol style="list-style-type: none"> 1. Top Link Out Of Adjustment 	<ol style="list-style-type: none"> 1. Adjust Top Link So Both Gangs Make Ground Contact Together / Equally 2. Add Spring Pressure To Rear Gangs
Plugging Between Blades	<ol style="list-style-type: none"> 1. Extremely Wet Soil 2. Gangs Set At Too Great An Angle 3. Not Using Blade Scrapers 	<ol style="list-style-type: none"> 1. Allow Soil To Dry 2. Reduce Angle 3. Install Scrapers

Replacement Parts

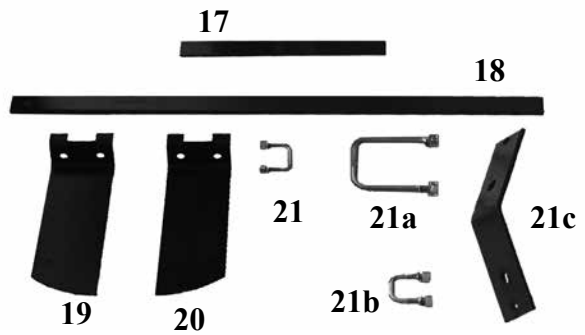
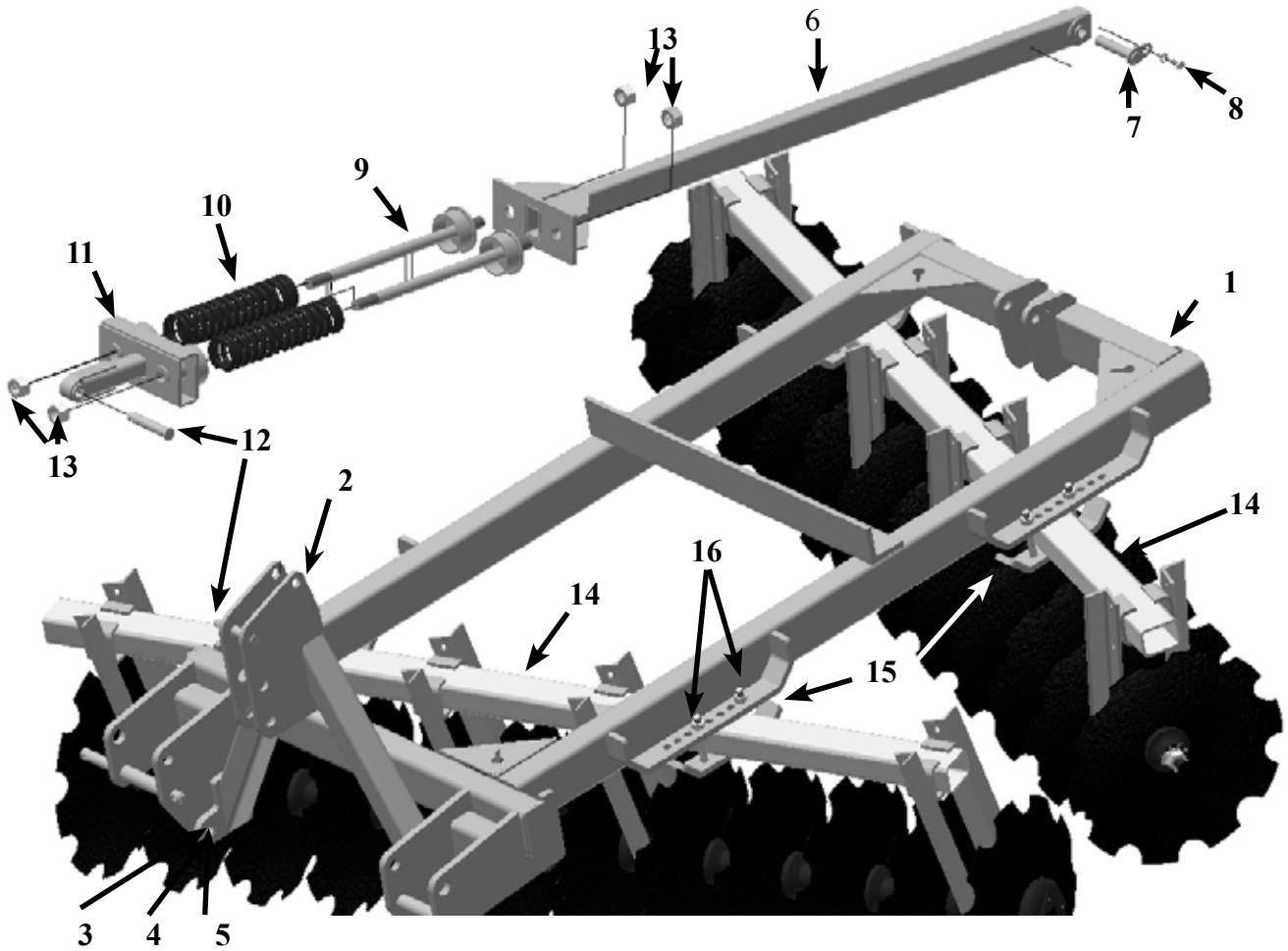

Replacement Parts

Ref.#	Part Number	Qty	Description
1	234-8045	1	OSL Frame 6' and 7 1/2' Models
	234-8020	1	OSL Frame 9' Model
2	205-3200	1	A-Frame Mast, All Models
3	232-0475	2	Deck to Mast Bushing
4	HC516C48Z	2	Bolt, 1 - 8 x 3" Grade 5 Zinc
5	WUS1Z	4	Flat Washer, USS 1" Zinc
	NNE1CZ	2	Nylon Lock Nut 1" - 8 Grade 5 Zinc
6	234-8040	1	Back Brace Arm 6' & 7 1/2' Models
	234-8005	1	Back Brace Arm 9' Model
7	234-8025	1	Pivot Pin
8	HC58C16Z	1	Bolt 1/2" - 13 x 1" Grade 5 Zinc
	WSA50Z	1	Flat Washer SAE 1/2" Grade 5 Zinc
9	234-8035	2	Cup Shaft
10	234-001	2	Coil Spring
11	234-8010	1	Top Spring Stop
12	500-22	2	Top Link Hitch Pin Cat. II
13	NNE8118CZ	4	Nylon Lock Nut 1 1/8" - 7 Grade C Zinc
14	700-234-0028	2	Gang Arm, 4"x 3"x 5/16"x 60" Long, OSL-600
	700-234-0020	2	Gang Arm, 4"x 3"x 5/16"x 79-1/2" Long, OSL-750
	700-234-0034	2	Gang Arm, 4"x 3"x 5/16"x 96" Long, OSL-900
15	234-8015	4	Bottom Gang Arm Plate (typical, 4 places)
16	HC512C88Z	8	Bolt 3/4" - 10 x 5 1/2" Grade 8 Zinc (typical, 8 places)
	WSA34Z	8	Flat Washer SAE 3/4" Grade 8 Zinc (typical, 8 places)
	NNE34CZ	8	Nylon Lock Nut 3/4" - 10 Grade C Zinc (typical, 8 places)
17	DH-900-A6	optional	Bar, Mounting, Scraper, Furrow Filler, Extension
18	DH-600-50	optional	Bar, Mounting, Scraper, 30" OSL-600
	DH-750-003	optional	Bar, Mounting, Scraper, 38" OSL-750
	DH-900-109	optional	Bar, Mounting, Scraper, 48" OSL-900
19	DH-188R		Blade, Scraper, Right
20	DH-188L		Blade, Scraper, Left
21	DH-195		U-Bolt, 3/8" x 1-1/2" x 1-1/2"
21a	DH-197		U-Bolt, 1/2" x 4" x 4"
21b	DH-196		U-Bolt, 1/2" x 1-1/2" x 1-3/4"
21c	DH-198		Bracket, Mount, Scraper Bar

Ordering replacement parts

Please contact the nearest Brown dealer for replacements parts. They will be able to meet most of your equipment needs. PLEASE HAVE MODEL NUMBER AND SERIAL NUMBER AVAILABLE.

Replacement Parts

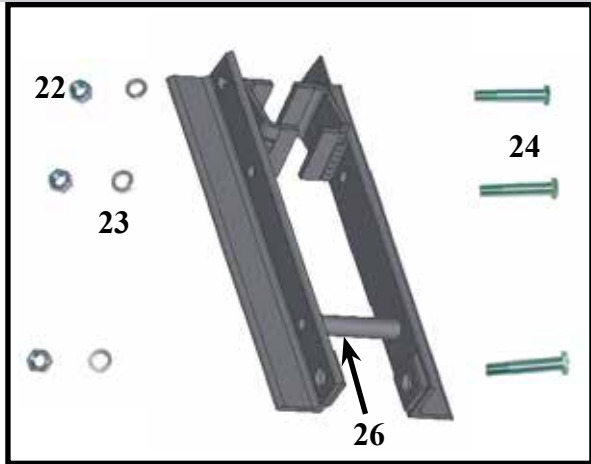

See page 13 for Bearing replacement instructions.

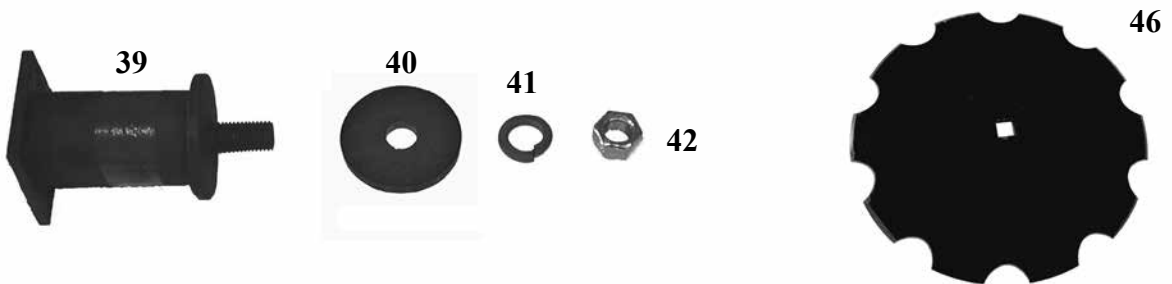

Images not to scale.

Replacement Parts

Ref.#	Part Number	Qty	Description
22	HN258CZ	3 per Hanger Assy	Nut, Hex 5/8" NC GR2 Zinc
23	LOC58Z	3 per Hanger Assy	Washer, Lock 5/8" Zinc
24	HC510C104Z	3 per Hanger Assy	Bolt, 5/8" X 6 1/2" NC GR5 For Bearing Hangers
25	DH-1254B	8	Bearing Hanger Assembly
26	DH-1254A	1 per Hanger Assy	Bearing Hanger Spacer
27	DH-95	1 per Gang	Axle, 1-1/8" x 31" OSL-600
	DH-99	1 per Gang	Axle, 1-1/8" x 39-3/4" OSL-750
	DH-97	1 per Gang	Axle, 1-1/8" x 48-3/4" OSL-900
28	DH-204	varies	Washer, Flat, Square Hole
29	DH-119	1 per Gang	Washer, Flat, 1-1/8"
30	NNE8118CZ	1 per Gang	Nut, 1-1/8"
31	DH-111		Spacer, Bearing, Long 4-1/2"
32	DH-113		Housing, Bearing
33	DH-115		Bearing, Ball
34	DH-117		Ring, Lock
ASSY.	DH-115A	8	Bearing, Assembly (Ref# 32, 33, & 34)
35	DH-112		Spacer, Bearing, Short 2-5/8
36	DH-107A		Washer, Bumper With Holes
37	DH-106		Spacer, Blade, 9"
38	DH-108		Washer, End Nut
39	DH-122	optional	Adapter, Furrow Filler
40	DH-123	optional	Washer, Furrow Filler
41	DH-124	optional	Washer, Lock, 1"
42	DH-124A	optional	Nut, 1"
ASSY	DH-122A	optional	Assembly, Furrow Filler (Ref# 39, 40, 41, & 42)
43	255-2300	2	Pin, Lower Lift, Cat II/III Combo
44	TC-126A	4	Pin, Lynch
45	500-22	2	Pin, Top Hitch, Cat II
not shown	255-0004		Pin, Top Hitch, Cat III
46	DH-116-22	Varies by Model	Disc Blade 22"
	DH-116-20	1	Disc Blade 20"
47	MH-01	1	Manual Holder Tube

NOTE: When attaching implement to tractor with a **Quick Hitch**, **ALL** pins **MUST** be **CAT III** pins, both upper pin and lower pins, regardless of hitch category.

Ordering replacement parts

Please contact the nearest Brown dealer for replacements parts. They will be able to meet most of your equipment needs.

Offset Lift Disc Harrow

Version 2.0.0
February 2017



6001 E. Hwy 27 - Ozark, AL 36360
334.795.6603 - Fax: 334.795.3029