

Farm King

OPERATOR AND PARTS MANUAL

10' Tedder

Model RT10



Table Of Contents

Manufacturer’s Statement: For technical reasons, Buhler Industries Inc. reserves the right to modify machinery design and specifications provided herein without any preliminary notice. Information provided herein is of descriptive nature. Performance quality may depend on soil fertility, applied agricultural techniques, weather conditions, and other factors.

- Warranty Registration Form..... 1
- Introduction..... 3
 - Owner’s Information..... 5
 - Equipment Identification..... 6
- Safety..... 9
 - Safety Instructions..... 11
 - Fire Prevention..... 14
 - Safety Signs And Equipment Decals..... 16
 - Safety Sign-Off Form..... 19
- Operation..... 21
 - Pre-Operation Checklist..... 23
 - Tractor Requirements..... 23
 - Entering The Operator’s Position..... 24
 - Leaving The Operator’s Position..... 24
 - Connecting To Tractor..... 24
 - Connecting The PTO Driveline..... 27
 - Tilt Adjustment..... 31
 - Field Operation..... 32
 - Transporting..... 35
- Maintenance..... 37
 - Troubleshooting..... 39
 - Service Schedule Chart..... 40
 - Lubrication..... 41
 - Gearbox..... 43
 - Cleaning..... 43
 - Tine Replacement..... 43
 - Safety And Equipment Signs..... 44
 - Storage And Return To Service..... 44
- Parts Identification..... 45
 - General Parts Information..... 47
 - Guards..... 47
 - Pull-Type Hitch..... 48

Three-Point Hitch.....	50
Main Components.....	52
Driveline.....	56
PTO - Pull-Type Hitch - 8020436.....	58
PTO - Three-Point Hitch - 8020435.....	59
Decal Kit.....	60
Specifications And Shipping Kit Numbers.....	61
Specifications.....	63
Shipping Kit And Bundle Numbers.....	64
Hardware Torque Values.....	65
Warranty.....	67
Farm King Base Limited Warranty.....	69

Warranty Registration Form

This form must be filled out by the dealer and signed by both the dealer and the customer at the time of delivery.

Customer Name:	
Customer Address:	
City:	Prov / State:
Postal / Zip Code:	Phone:

Dealer Name:	
Dealer Address:	
City:	Prov / State:
Postal / Zip Code:	Phone:

Equipment Model:	Serial Number:	Delivery Date:
------------------	----------------	----------------

I have thoroughly instructed the buyer on the above described equipment which review included the Operator and Parts Manual content, equipment care, adjustments, safe operation and applicable warranty policy.

Dealer Inspection Report

- Rotors Turn Freely
- Check Gear Box Oil Level
- Tines Properly Oriented
- Fasteners Tight
- Lubricate Machine
- Slip Clutch (If equipped) Is Properly Adjusted

Safety

- Safety Chain On Hitch
- All Decals Installed
- Guards And Shields Installed And Secure
- Review Operating And Safety Instructions
- Check Gear Box For Leaks

Date:	Dealer Rep. Signature:
-------	------------------------

The above equipment and Operator And Parts Manual have been received by me and I have been thoroughly instructed as to care, adjustments, safe operation and applicable warranty policy.

Date:	Customer / Owner Signature:
-------	-----------------------------

Remove this Warranty Registration Form from the Operator And Parts Manual. Make two copies of the form. Send original Warranty Registration Form to Farm King. Give one copy to the customer and the dealer will keep one copy.

Farm King



Introduction

This Operator And Parts Manual was written to give the owner / operator instructions on the safe operation, maintenance and part identification of the Farm King equipment. **READ AND UNDERSTAND THIS OPERATOR AND PARTS MANUAL BEFORE OPERATING YOUR FARM KING EQUIPMENT.** If you have any questions, see your Farm King dealer. This manual may illustrate options and accessories not installed on your Farm King equipment.

Owner’s Information..... 5

 Serial Number Location..... 5

 Manual Storage..... 5

Equipment Identification..... 6

 Component Location - Three-Point Hitch Model..... 6

 Component Location - Pull-Type Hitch Model..... 7

Farm King



Owner's Information

Thank you for your decision to purchase a Farm King Tedder. To ensure maximum performance of your equipment, it is mandatory that you thoroughly study the Operator and Parts Manual and follow the recommendations. Proper operation and maintenance are essential to maximize equipment life and prevent personal injury.

Operate and maintain this equipment in a safe manner and in accordance with all applicable local, state, and federal codes, regulations and / or laws. Follow all on-product labeling and instructions.

Make sure that all personnel have read this Operator and Parts Manual and thoroughly understand safe and correct operating, installation and maintenance procedures.

Farm King is continually working to improve its products. Farm King reserves the right to make any improvements or changes as deemed practical and possible without incurring any responsibility or obligation to make any changes or additions to equipment sold previously.

Although great care has been taken to ensure the accuracy of this publication, Farm King, makes no warranty or guarantee of any kind, written or expressed, implied or otherwise with regard to the information contained within this manual. Farm King assumes no responsibility for any errors that may appear in this manual and shall not be liable under any circumstances for incidental, consequential or punitive damages in connection with, or arising from the use of this manual.

Keep this manual available for frequent reference. All new operators or owners must review the manual before using the equipment and annually thereafter. Contact your Farm King Dealer if you need assistance, information, or additional copies of the manual. Visit our website at www.farm-king.com for a complete list of dealers in your area.

The directions left, right, front and rear, as mentioned throughout this manual, are as viewed from the rear of the equipment.

Serial Number Location

Please enter the model and serial number in the space provided for easy reference.

Figure 1



Model Number: _____

Serial Number: _____

The serial number plate (Item 1) is located on the center housing [Figure 1].

Always use your serial number when requesting information or when ordering parts.

Manual Storage

Figure 2

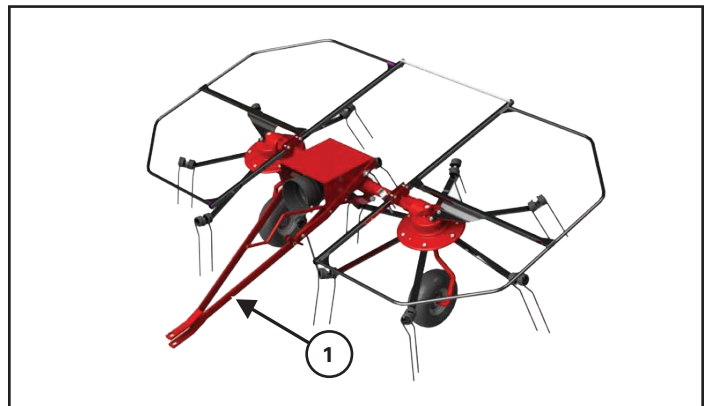

The operator and parts manual and other documents can be stored in the canister (Item 1), located on the hitch frame [Figure 2].

Component Location - Pull-Type Hitch Model

Figure 4

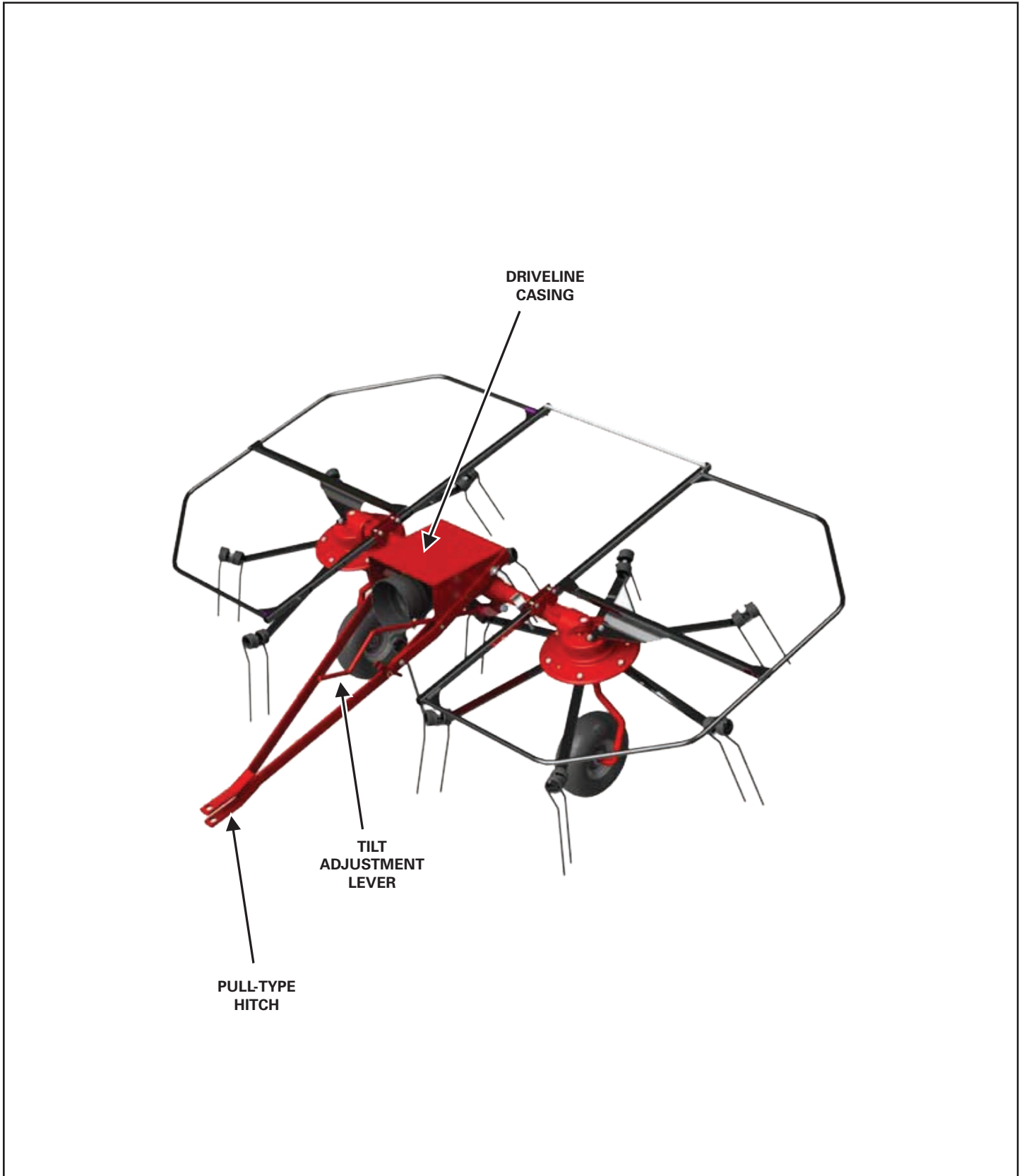

Farm King



Safety

- Safety Instructions.....11
 - Safety Symbols.....11
 - Qualified Operator Safety.....11
 - Use Safety Rules.....12
 - Safety Rules For Power Take-Off (PTO) Driven Equipment.....12
 - Machine Requirements And Capabilities.....13
 - Transport Safety.....13
- Fire Prevention.....14
 - Maintenance.....14
 - Operation.....14
 - Starting.....14
 - Electrical.....14
 - Hydraulic System.....14
 - Fueling.....14
 - Welding And Grinding.....15
 - Fire Extinguishers.....15
- Safety Signs And Equipment Decals.....16
- Safety Sign-Off Form.....19

Farm King





Safety Instructions

Safety Symbols

	Safety Alert Symbol
<p>This symbol with a warning statement means: "Warning, be alert! Your safety is involved!" Carefully read the message that follows.</p>	

	CAUTION
<p>The signal word CAUTION on the machine and in the manuals indicates a potentially hazardous situation which, if not avoided, may result in minor or moderate injury. It may also be used to alert against unsafe practices.</p>	

	DANGER
<p>The signal word DANGER on the machine and in the manuals indicates a hazardous situation which, if not avoided, will result in death or serious injury.</p>	

	WARNING
<p>The signal word WARNING on the machine and in the manuals indicates a potentially hazardous situation which, if not avoided, could result in death or serious injury.</p>	

	IMPORTANT
<p>This notice identifies procedures which must be followed to avoid damage to the machine.</p>	

Qualified Operator Safety

Operators must have instructions before operating the machine. Untrained operators can cause injury or death.

For an operator to be qualified, he or she must not use drugs or alcohol which impair alertness or coordination while working. An operator who is taking prescription drugs must get medical advice to determine if he or she can safely operate a machine and the equipment.

Understand the written instructions, rules and regulations:

- The written instructions from Farm King include the Warranty Registration, Dealer Inspection Report, Operator And Parts Manual and machine signs (decals).
- Check the rules and regulations at your location. The rules may include an employer's work safety requirements. Regulations may apply to local driving requirements or use of a Slow Moving Vehicle (SMV) emblem. Regulations may identify a hazard such as a utility line.

Have Training with Actual Operation:

- Operator training must consist of a demonstration and verbal instruction. This training is given by the machine owner prior to operation.
- The new operator must start in an area without bystanders and use all the controls until he or she can operate the machine safely under all conditions of the work area. Always fasten seat belt before operating.

Know the Work Conditions:

- Clear working area of all bystanders, especially small children and all obstacles that might be hooked or snagged, causing injury or damage.
- Know the location of any overhead or underground power lines. Call local utilities and have all underground power lines marked prior to operation.
- Wear tight fitting clothing. Always wear safety glasses when doing maintenance or service.

Use Safety Rules

- Read and follow instructions in this manual and the tractor's Operators Manual before operating.
- Under no circumstances should young children be allowed to work with this equipment.
- This equipment is dangerous to children and persons unfamiliar with its operation.
- Check for overhead and / or underground lines before operating equipment (if applicable).
- In addition to the design and configuration of equipment, hazard control and accident prevention are dependent upon the awareness, concern, prudence and proper training of personnel involved in the operation, transport, maintenance and storage of equipment.
- Check that the equipment is securely fastened to the tractor / towing vehicle. Make sure all the machine controls are in the NEUTRAL position before starting the machine.
- Operate the equipment only from the operator's position. Operate the equipment according to the Operator And Parts Manual.
- When learning to operate the equipment, do it at a slow rate in an area clear of bystanders, especially small children.
- DO NOT permit personnel to be in the work area when operating the equipment.
- The equipment must be used ONLY on approved tractors / transport vehicles. DO NOT modify the equipment in any way. Unauthorized modification may impair the function and / or safety and could affect the life of the equipment.
- Stop tractor engine, place all controls in neutral, set park brake, remove ignition key and wait for all moving parts to stop before servicing, adjusting, repairing, unplugging or filling.
- DO NOT make any adjustments or repairs on the equipment while the machine is running.
- Keep shields and guards in place. Replace if damaged.
- Keep hands, feet, hair and clothing away from all moving parts.

Safety Rules For Power Take-Off (PTO) Driven Equipment

- Keep PTO shields and all guards in place. Replace damaged or missing shields and guards before operating.
- Follow warnings and instructions on machine signs (decals). Replace damaged or missing decals.
- Do not wear loose or bulky clothing around the PTO or other moving parts.
- Keep bystanders away from PTO driven equipment, and never allow children near machines.
- Read and understand the manuals for the PTO driven equipment and be aware of safe operating procedures and hazards that may not be readily apparent.
- Never operate over 540 rpm.
- Always walk around equipment to avoid coming near a turning PTO driveline. Stepping over, leaning across or crawling under a turning PTO driveline can cause entanglement.
- Position the machine and equipment hitch correctly to prevent driveline stress and separation.
- Use caution when raising PTO driven equipment.
- Excessive driveline angle can cause driveline damage.

Machine Requirements And Capabilities

- Fasten seat belt securely. If equipped with a foldable Roll-Over Protective Structure (ROPS), only fasten seat belt when ROPS is up and locked. DO NOT wear seat belt if ROPS is down.
- Stop the machine and engage the parking brake. Install blocks in front of and behind the rear tires of the machine. Install blocks underneath and support the equipment securely before working under raised equipment.
- Keep bystanders clear of moving parts and the work area. Keep children away.
- Use increased caution on slopes and near banks and ditches to prevent overturn.
- Make certain that the Slow Moving Vehicle (SMV) emblem is installed so that it is visible and legible. When transporting the equipment, use the flashing warning lights (if equipped) and follow all local regulations.
- Operate this equipment with a machine equipped with an approved Roll-Over Protective Structure (ROPS). Always wear seat belt when the ROPS is up. Serious injury or death could result from falling off the machine.
- Before leaving the operator's position:
 1. Always park on a flat level surface.
 2. Place all controls in neutral.
 3. Engage the parking brake.
 4. Stop engine.
 5. Wait for all moving parts to stop.
- Carry passengers only in designated seating areas. Never allow riders on the machine or equipment. Falling off can result in serious injury or death.
- Start the equipment only when properly seated in the operator's seat. Starting a machine in gear can result in serious injury or death. Operate the machine and equipment from the operator's position only.
- The parking brake must be engaged before leaving the operator's seat. Roll-away can occur because the transmission may not prevent machine movement.

Transport Safety

- Do not exceed 20 mph (32 kph). Reduce speed on rough roads and surfaces.
- Comply with state and local laws governing highway safety and movement of machinery on public roads.
- The use of flashing amber lights is acceptable in most localities. However, some localities prohibit their use.
- Local laws should be checked for all highway lighting and marking requirements.
- Always yield to oncoming traffic in all situations and move to the side of the road so any following traffic may pass.
- Always enter curves or drive up or down hills at a low speed and at a gradual steering angle.
- Never allow riders on either tractor or equipment.
- Keep tractor / towing vehicle in a lower gear at all times when traveling down steep grades.
- Maintain proper brake settings at all times (if equipped).

Fire Prevention

Maintenance

- The machine and some equipment have components that are at high temperatures under normal operating conditions. The primary source of high temperatures is the engine and exhaust system. The electrical system, if damaged or incorrectly maintained, can be a source of arcs or sparks.
- Flammable debris (leaves, straw, etc.) must be removed regularly. If flammable debris is allowed to accumulate, it can cause a fire hazard. Clean often to avoid this accumulation. Flammable debris in the engine compartment is a potential fire hazard. The operator's area, engine compartment and engine cooling system must be inspected every day and cleaned if necessary to prevent fire hazards and overheating.
- All fuels, most lubricants and some coolant mixtures are flammable. Flammable fluids that are leaking or spilled onto hot surfaces or onto electrical components can cause a fire.

Operation

- The Farm King machine must be in good operating condition before use.
- Check all of the items listed on the service schedule under the 8 hour column before operation. (See Maintenance section)
- Do not use the machine where exhaust, arcs, sparks or hot components can contact flammable material, explosive dust or gases.

Starting

- Do not use ether or starting fluids on any engine that has glow plugs. These starting aids can cause explosion and injure you or bystanders.
- Use the procedure in the tractor's operator's manual for connecting the battery and for jump starting.

Electrical



- Check all electrical wiring and connections for damage. Keep the battery terminals clean and tight. Repair or replace any damaged part or wires that are loose or frayed.
- Battery gas can explode and cause serious injury. Do not jump start or charge a frozen or damaged battery. Keep any open flames or sparks away from batteries. Do not smoke in battery charging area.

Hydraulic System

- Check hydraulic tubes, hoses and fittings for damage and leakage. Never use open flame or bare skin to check for leaks. Hydraulic tubes and hoses must be properly routed and have adequate support and secure clamps. Tighten or replace any parts that show leakage.
- Always clean fluid spills. Do not use gasoline or diesel fuel for cleaning parts. Use commercial nonflammable solvents.

Fueling



- Stop the engine and let it cool before adding fuel. No smoking. Do not refuel a machine near open flames or sparks. Fill the fuel tank outdoors.

Welding And Grinding

- Always clean the machine and equipment, disconnect the battery, and disconnect the wiring from the machine controls before welding. Cover rubber hoses, battery and all other flammable parts. Keep a fire extinguisher near the machine when welding.
- Have good ventilation when grinding or welding painted parts. Wear dust mask when grinding painted parts. Toxic dust or gas can be produced.
- Dust generated from repairing nonmetallic parts such as hoods, fenders or covers can be flammable or explosive. Repair such components in a well ventilated area away from open flames or sparks.

Fire Extinguishers



- Know where fire extinguishers and first aid kits are located and how to use them. Inspect the fire extinguisher and service the fire extinguisher regularly. Obey the recommendations on the instructions plate.

Safety Signs And Equipment Decals

Follow the instructions on all the signs (decals) that are on the equipment. Replace any damaged signs (decals) and be sure they are in the correct locations. Equipment signs are available from your Farm King equipment dealer.

Figure 5



Danger to be hooked or to get caught on. With the rotation of arms, the tines may hook clothes or other objects [Figure 5].

Figure 6



Danger of flying objects. With the rotation of arms, the tines could pick up and throw objects from the working site. Maintain minimum safe distance [Figure 6].

Figure 7

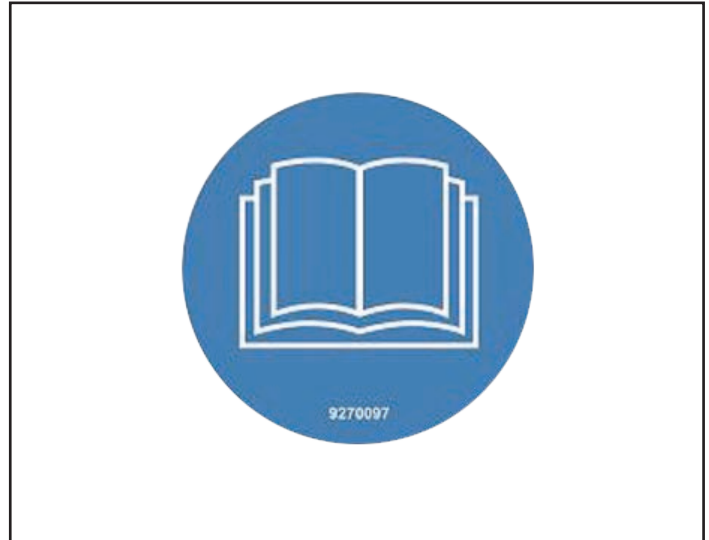

Obligation of reading the use and maintenance manual. Read and follow instructions in this manual and the tractor's Operators Manual before operating [Figure 7].

Figure 8



Prohibition to perform repairs or maintenance with parts in motion. It is absolutely forbidden to adjust, lubricate, repair or replace parts in motion. These tasks must be performed with the P.T.O. disengaged, the tractor engine off and the ignition keys removed from the dashboard [Figure 8].

Figure 9



Prohibition of stopping or transit. It is prohibited to others than authorized personnel to stop or transit in the hay tedder proximity, when it is running. Remain at a safe distance [Figure 9].

Figure 10



PTO requirement. Verify that the number of revolutions at the tractor PTO exit is of 540 rpm and that the rotation is clockwise [Figure 10].

Figure 11



Danger of entanglement. Keep clear of all rotating or spinning components of the equipment [Figure 11].

Figure 12



Gearbox contains oil [Figure 12].

Figure 13

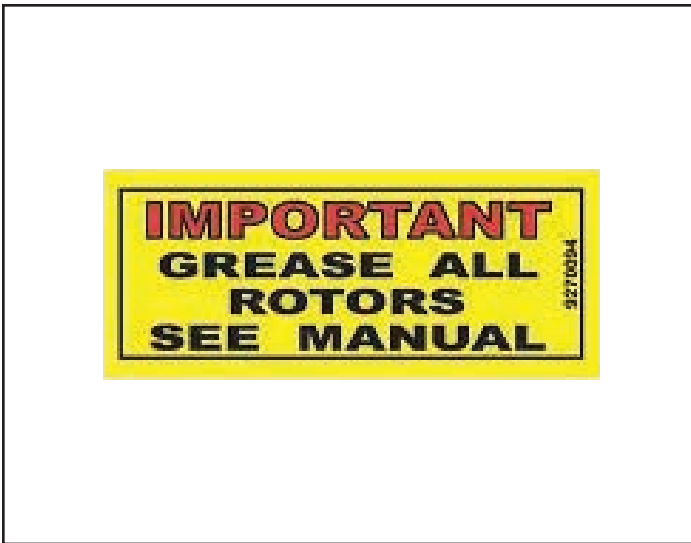

Grease all rotors [Figure 13].

Figure 14



Hoisting locations [Figure 14].

Figure 15



Greasing locations [Figure 15].

Farm King



Operation

Pre-Operation Checklist.....	23
Tractor Requirements.....	23
Entering The Operator’s Position.....	24
Leaving The Operator’s Position.....	24
Connecting To Tractor.....	24
Three-Point Hitch.....	25
Pull-Type Hitch.....	26
Connecting The PTO Driveline.....	27
PTO Driveline Length Check.....	28
PTO Driveline Bottoming Out Check.....	28
Reducing The PTO Driveline Length.....	29
PTO Driveline Engagement Check.....	30
Tilt Adjustment.....	31
Three-Point Hitch.....	31
Pull-Type Hitch.....	31
Operating Angle.....	31
Field Operation.....	32
Preliminary information.....	32
Working Configuration.....	32
Working process.....	33
Changing Direction / Reverse.....	34
Danger Zones.....	34
Finishing Work.....	34
Transporting.....	35

Farm King



Pre-Operation Checklist

Before operating the equipment for the first time and each time thereafter, check the following items:

1. Lubricate the equipment per the schedule outline in the Maintenance Section.
2. Check the hitch for damaged, loose or missing parts. Repair as needed before operation.
3. Check the tines for damaged, loose or missing parts. Repair as needed before operation. Clear out any tangled material.
4. Fully clean the equipment.
5. Inspect all safety reflective decals, slow moving vehicle decals and lights where applicable.
6. Verify that the Tedder is properly connected to the tractor with the safety chain.

	WARNING
AVOID INJURY OR DEATH	
<p>Wear safety glasses to prevent eye injury when any of the following conditions exist:</p> <ul style="list-style-type: none"> • When fluids are under pressure. • Flying debris or loose material is present. • Engine is running. • Tools are being used. <p>To prevent serious injury or death from moving parts:</p> <ul style="list-style-type: none"> • Keep hands, feet, hair and clothing away from moving parts. • Disconnect and lockout power source before adjusting or servicing. 	

Tractor Requirements

The tractor must satisfy the following requirements, depending on model.

Pull-Type Hitch Models:

- Recommended 20 HP
- Tow style hitch
- Rear auxiliary hydraulic outlets

Three-Point Hitch Models:

- Recommended 20 HP
- Three-point universal hitch with hydraulic lift
- Rear auxiliary hydraulic outlets

	WARNING
	
<ul style="list-style-type: none"> • Do NOT exceed 540 RPM PTO. • Keep PTO shields and all guards in place. • Keep away from moving parts. • Keep bystanders away. 	

Entering The Operator’s Position

Enter the operator’s position, start the engine, and release the parking brake.

	IMPORTANT
Follow the instructions in your tractor’s operation manual for the correct procedure.	

Leaving The Operator’s Position

Always perform the following steps when leaving the operator’s position:



	WARNING
AVOID INJURY OR DEATH	
Before you leave the operator’s position:	
<ul style="list-style-type: none"> • Always park on a flat level surface. • Place all controls in NEUTRAL. • Engage the park brake. • Stop the engine and remove the key. • Wait for all moving parts to stop. 	

Connecting To Tractor

Always inspect the tractor’s hitch and equipment’s hitch before connecting. See the tractor’s owner’s manual.

Move the tractor into position in front of the equipment.

	WARNING
	
AVOID INJURY OR DEATH	
Keep fingers and hands out of pinch points when connecting and disconnecting equipment.	

	WARNING
	
AVOID INJURY OR DEATH	
Before moving the tractor, look in all directions and make sure no bystanders, especially small children are in the work area.	
Do not allow anyone between the tractor and the equipment when backing up to the equipment for connecting.	

Three-Point Hitch

Move the tractor drawbar into the storage position or remove (if necessary) to prevent interference with operation (see the tractor's operator's manual for the correct procedure).

Figure 16

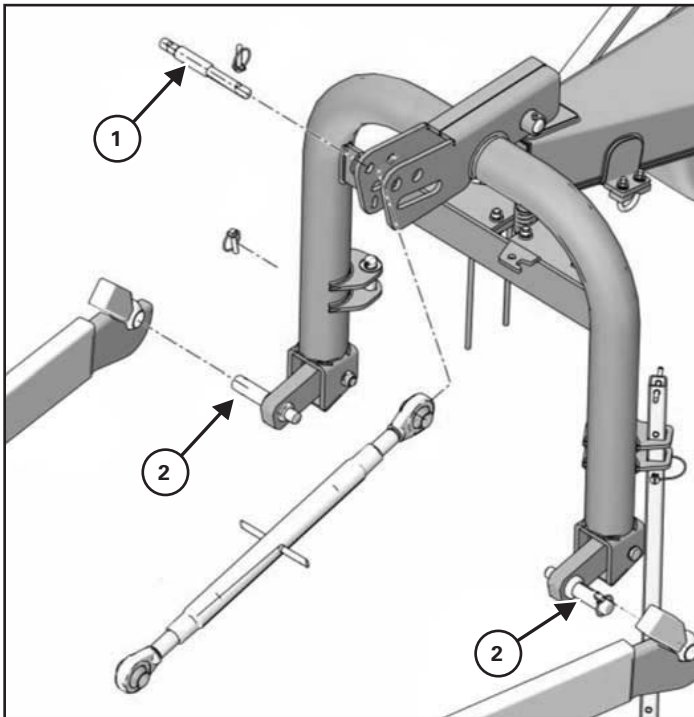

Remove the top implement mounting pin (Item 1) and lynch pin from the equipment [Figure 16].

Remove the lynch pins from the left and right lower mounts (Item 2) [Figure 16].

Move the tractor backwards, aligning the tractor's three-point hitch and equipment's three-point mounts.

Install the left and right lower three-point mounts of the tractor to the equipment's left and right lower mounting pins.

Reinstall the lynch pins.

Lower the top link of the three-point hitch until it aligns with the equipment's upper mount.

Reinstall the mounting pin and lynch pin.

NOTE: It may be necessary to lengthen or shorten the top link to align it with the equipment's mounting hole (see the tractor's operator's manual for the correct procedure).

The equipment can be leveled front to back by adjusting the top link (see the tractor's operator's manual for the correct procedure).

Adjust the lower link sway chains or blocks on the tractor to restrict side movement of the equipment when operating.

	IMPORTANT
<p>Always use a hitch pins of adequate size and strength and a retaining pin with a locking device.</p>	

Figure 17

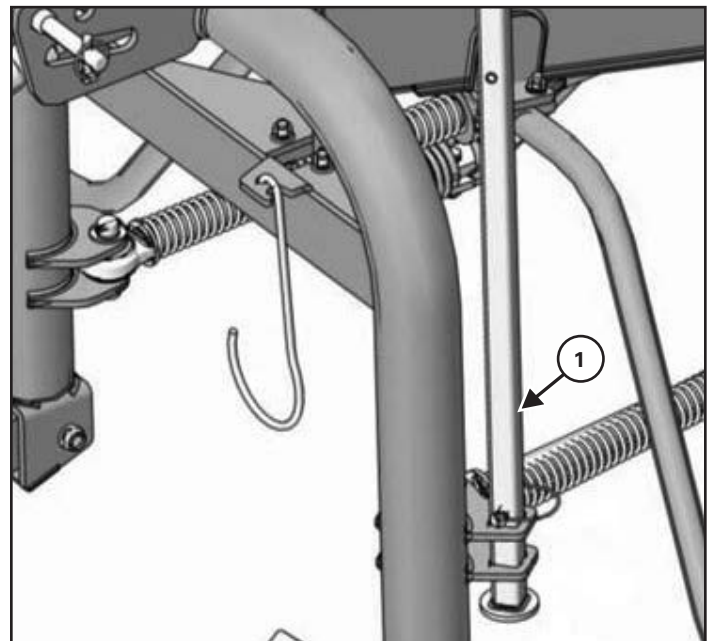

Remove the retaining pin and slide the support leg (Item 1) up into the storage position. Reinstall the retaining pin at the lower hole on the leg [Figure 7].

Pull-Type Hitch

Move the tractor backwards, aligning the drawbar with the tedder hitch (see the tractor's operator's manual for the correct procedure).

Figure 18

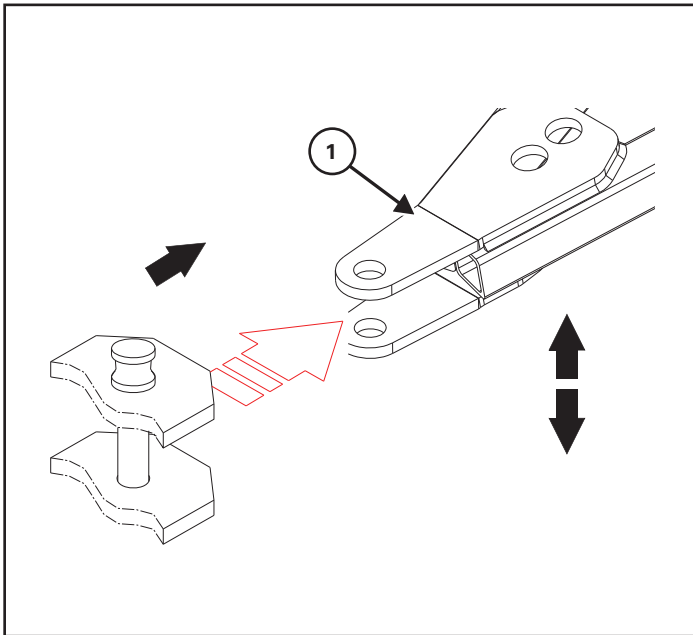

Lower or raise the Tedder hitch (Item 1) until aligned with the tractor's drawbar [Figure 18].

Align the drawbar hitch pin hole with the tedder hitch pin hole.

	<h1 style="margin: 0;">IMPORTANT</h1>
<p>Always use a hitch pins of adequate size and strength and a retaining pin with a locking device.</p>	

Figure 19

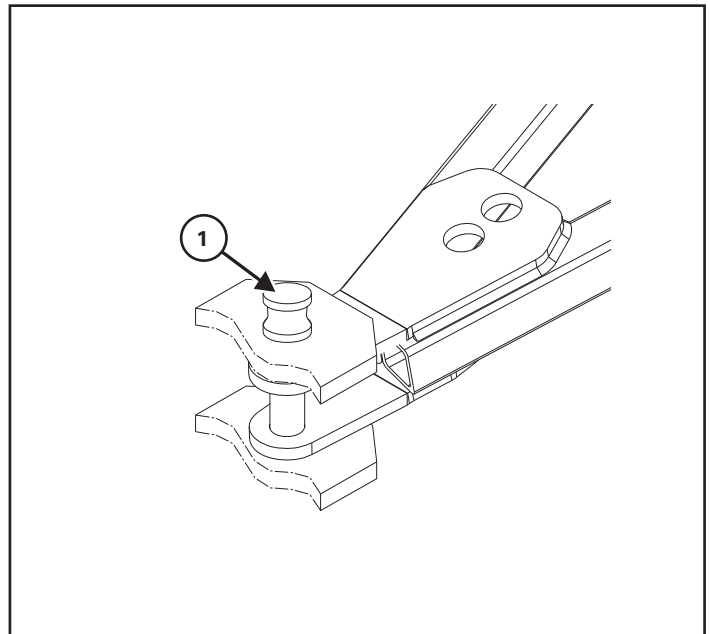

Install the hitch pin (Item 1) and retaining pin to securely fasten the tedder hitch to the tractor drawbar [Figure 19].

Attach the safety chain (if equipped).

Connecting The PTO Driveline

Stop the engine and leave the operator's position (see "Leaving The Operator's Position" on page 24).

	WARNING
AVOID INJURY OR DEATH	
Warnings on the machine and in the manuals are for your safety. Failure to obey warnings can cause serious injury or death.	

NOTE: Clean and grease tractor's PTO shaft and PTO driveline coupling each time driveline is connected.

	IMPORTANT
Improper hitch installation can cause PTO driveline damage.	
<ul style="list-style-type: none"> • Do not modify the hitch. • Make sure the PTO driveline is of adequate length and that u-joints are in the correct phase. 	

Remove the PTO driveline from the storage position (if applicable).

Figure 20

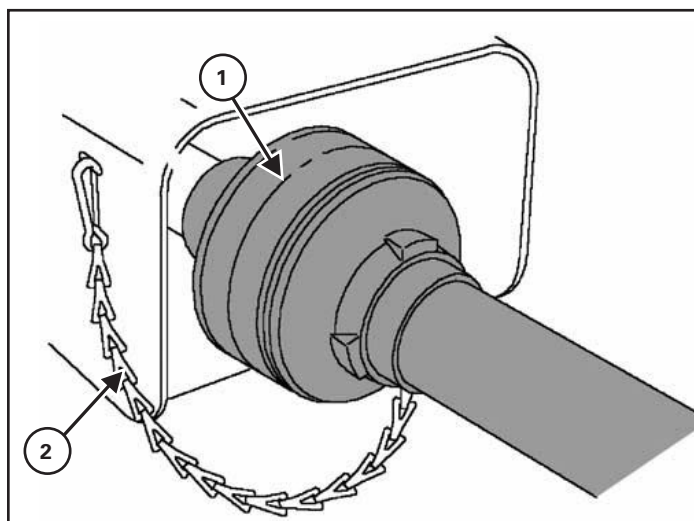

Retract the collar (Item 1) and slide the PTO driveline onto the tractor PTO shaft. Release the collar and the driveline will lock onto the shaft. Push and pull the PTO driveline back and forth several times and make sure it is securely attached to the PTO shaft [Figure 20].

Install PTO driveline safety chain (Item 2) [Figure 20].

NOTE: The PTO driveline must have a means to retain it to the PTO shaft on the tractor.

	WARNING
	
<ul style="list-style-type: none"> • Do NOT exceed 540 RPM PTO. • Keep PTO shields and all guards in place. • Keep away from moving parts. • Keep bystanders away. 	

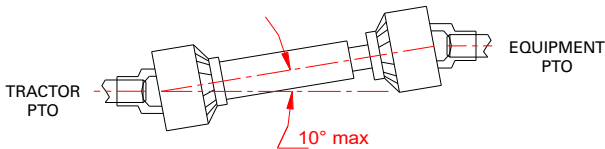
	IMPORTANT
	
The PTO should not be engaged while the engine is off.	
The PTO angle should not exceed 10° when connected to the equipment.	

PTO Driveline Length Check

Due to variations in distances between tractor PTO shafts and implement input shafts, drivelines may need to be shortened or a longer shaft may be required.

When fitting the implement to the tractor, the PTO driveline, with telescoping sections, must be inspected. When the sections are at the most compressed operating position, the sections must not "bottom out".

At its shortest length, there must be at least 2 in. (50.8 mm) of clearance between each section end and opposite section end at the most compressed operating position.

When the sections are at the most extended position, there must be sufficient engagement between the sections.

At its farthest operating extension, a minimum section engagement of 33% of shaft length must be maintained.

PTO Driveline Bottoming Out Check

Stop the engine and leave the operator's position (see "**Leaving The Operator's Position**" on page 24).

Make sure the PTO driveline and all rotating components have come to a complete stop before leaving the operator's position (if applicable).

Figure 21

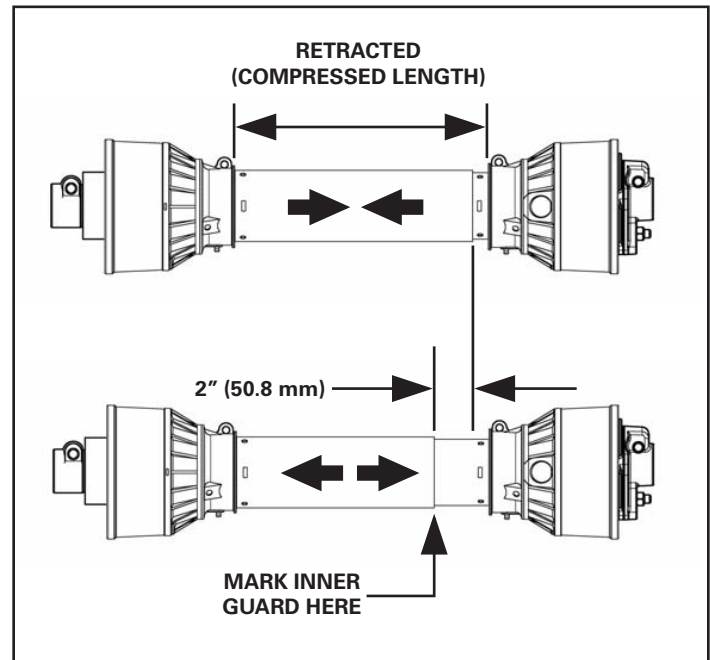

1. Disconnect the PTO driveline from the tractor and slide the PTO driveline together until fully retracted (compressed).
2. Measure the retracted (compressed) length of PTO driveline [Figure 21].
3. Extend the PTO driveline 2 in. (50.8 mm) from the retracted length and place a mark on the inner guard at the end of the outer guard [Figure 21].
4. Reattach the PTO driveline to the tractor PTO shaft.
5. Enter the operator's position. Start the engine.
6. With the rear PTO DISENGAGED, raise and lower the implement and watch the PTO driveline extend and retract.
7. If the outer PTO driveline guard slides in (retracts) over the mark at any point of travel, the PTO driveline needs to be shortened.

Reducing The PTO Driveline Length

Stop the engine and leave the operator's position (see "Leaving The Operator's Position" on page 24). Make sure the PTO driveline and all rotating components have come to a complete stop before leaving the operator's position.

WARNING

AVOID INJURY OR DEATH

- Do NOT exceed the rated implement PTO speed.
- Stay clear of rotating driveline.
- Keep bystanders away.
- Keep hands, feet, clothing and long hair away.
- Keep PTO shields and all guards in place.
- Disengage PTO, move the tractor controls to the Neutral position, stop the engine and make sure all rotating components are stopped before leaving the operator's position.
- Do NOT service the tractor or implement with the PTO engaged.
- Do NOT service the implement in a raised position unless properly blocked and with all rotating components stopped.
- Disengage PTO for road travel.

Remove the PTO driveline from the tractor and place in storage position (if equipped).

Enter the operator's position. Start the engine.

Raise or lower the three-point implement to get the shortest distance between the tractor PTO shaft and three-point implement gearbox PTO shaft. Stop the engine and leave the operator's position.

Pull the PTO driveline apart and reinstall each individual section; one half to the tractor PTO shaft and one half to the implement gearbox PTO shaft.

Figure 22

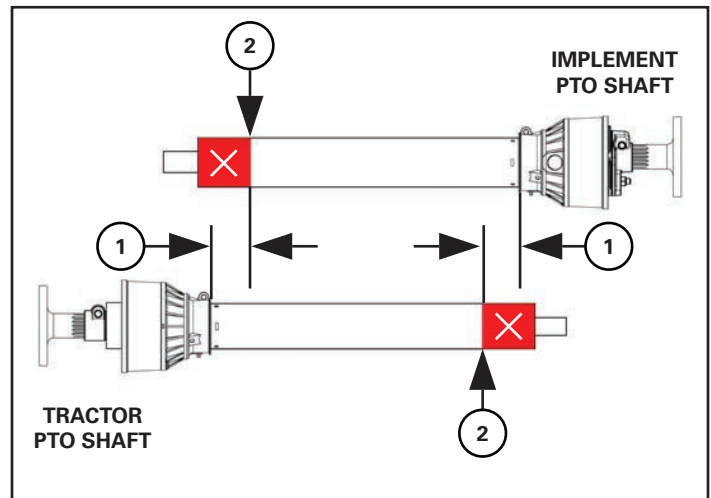

1. Hold PTO driveline sections parallel to one another and measure back 2 in. (50.8 mm) (Item 1) from the yoke of each section and place mark on opposite section. Cut the plastic shield at this length (Item 2) [Figure 22].

Figure 23

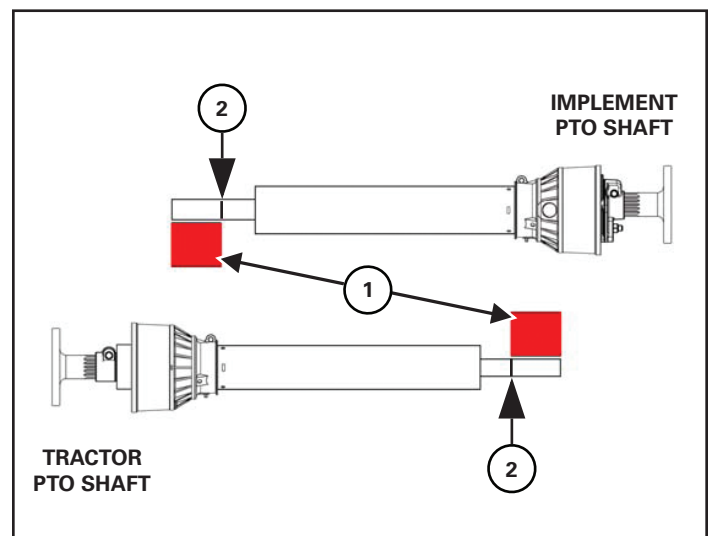

2. Align the cut off lengths (Item 1) with the end of the inner & outer shafts. Place a mark (Item 2) on the inner & outer shafts and cut the inner & outer shafts off at this length [Figure 23].
3. Round off all sharp edges and debur.
4. Thoroughly grease and install the PTO driveline halves together.
5. Recheck for proper operation.

PTO Driveline Engagement Check

Stop the engine and leave the operator's position (see "Leaving The Operator's Position" on page 24).

Make sure the PTO driveline and all rotating components have come to a complete stop before exiting the tractor.

1. Disconnect the PTO driveline from the tractor and fully slide the driveline sections together (retracted).
2. Measure the retracted (compressed) length of the PTO driveline between the bases of the plastic guards [Figure 24].
3. Multiply the retracted driveline length by 1.667 to determine the PTO driveline Maximum Operating Length. (i.e.: 25.5 in. (647.7 mm) x 1.667 = 42.5 in. (1079.7 mm) Maximum Operating Length).
4. Attach the PTO driveline to the tractor PTO output shaft.
5. Enter the operator's position.
6. With the PTO driveline attached, position the three-point implement to where the telescoping PTO driveline is at its maximum operating extension.
7. Stop the engine and leave the operator's position. Make sure the PTO driveline and all rotating components have come to a complete stop before leaving the operator's position.
8. Measure the length of the PTO driveline between the bases of the plastic shields to determine the maximum operating length [Figure 24].

If the measured maximum operating length is less than the Maximum Operating Length calculation (from Step 3), the PTO driveline has adequate engagement

If the measured maximum operating length is equal to or more than the Maximum Operating Length calculation (from Step 3), the PTO driveline does not have adequate engagement and should be replaced with a longer driveline. See your Farm King dealer for available PTO drivelines.

Figure 24

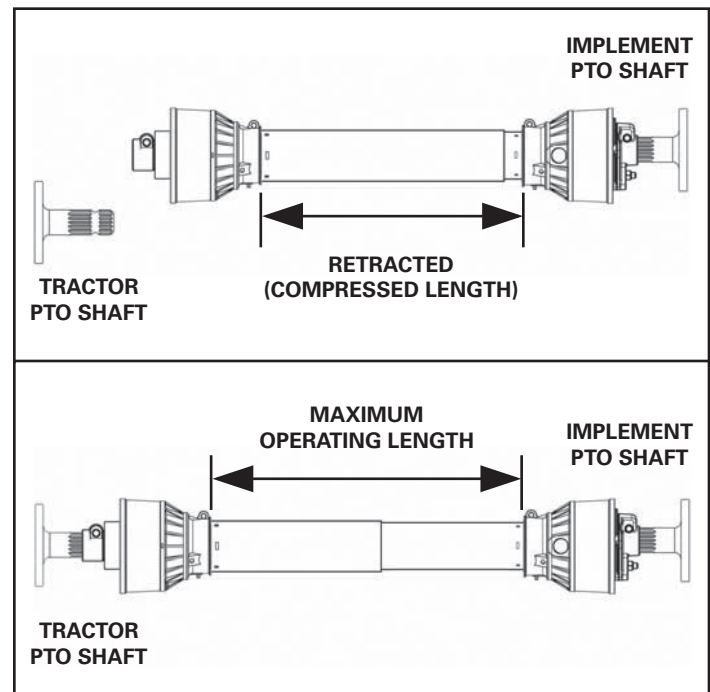

Tilt Adjustment

Three-Point Hitch

Figure 25

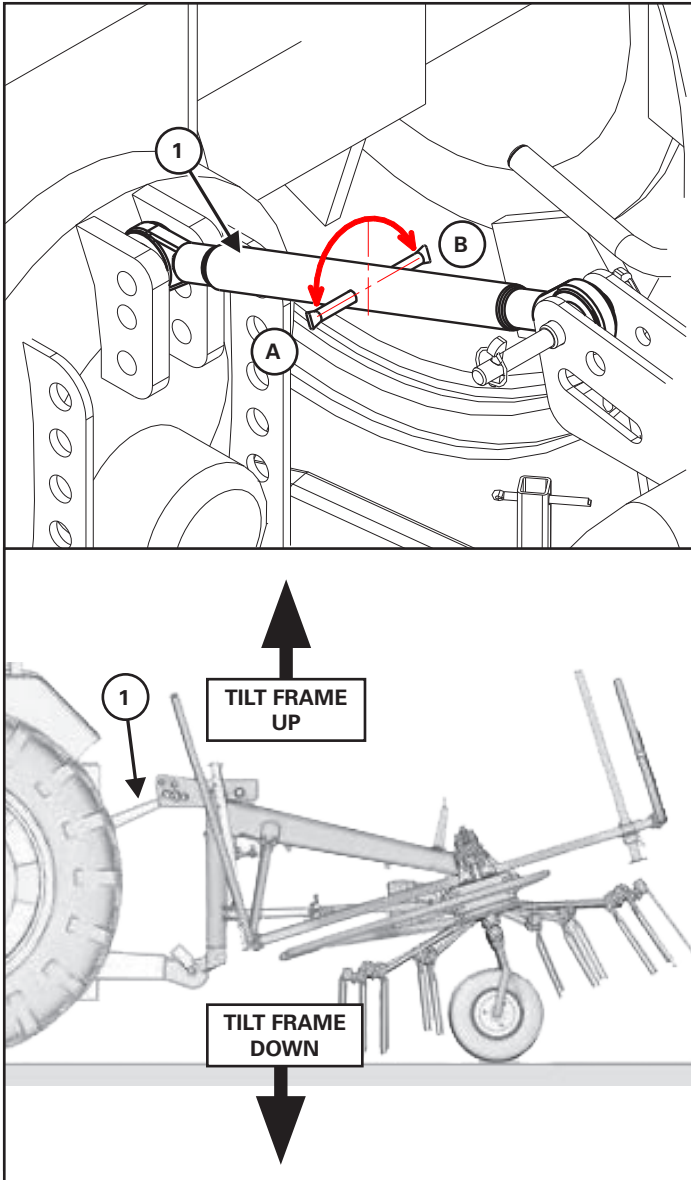

Turn in/out the top linkage (Item 1) of the three-point hitch to change the rotary unit tilt with respect to the ground [Figure 25].

Turn the linkage counter clockwise (Direction A) to extend the rod and push the equipment frame upwards, reducing the inclination [Figure 25].

Turn the linkage clockwise (Direction B) to retract the rod and pull the equipment frame downwards, increasing the inclination [Figure 25].

Pull-Type Hitch

Figure 26

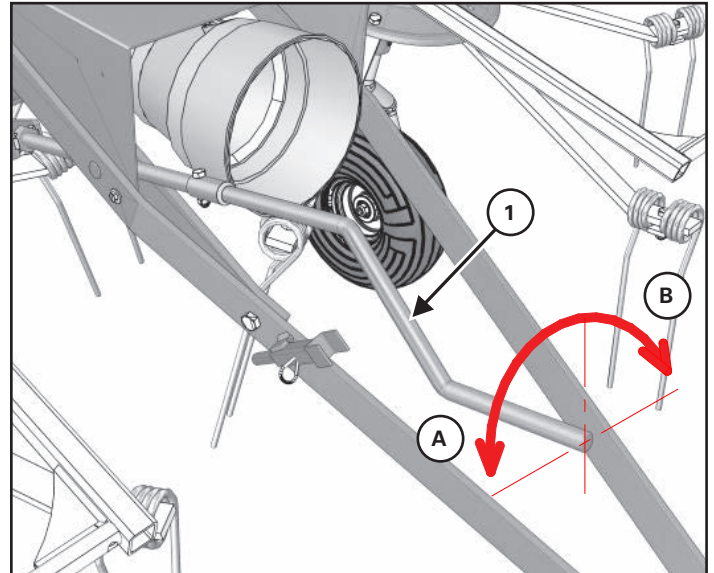

Turn the adjustment lever (Item 1) of the pull-type hitch to change the rotary unit tilt with respect to the ground [Figure 26].

Turn the lever counter clockwise (Direction A) to push the equipment frame upwards, reducing the inclination [Figure 26].

Turn the lever clockwise (Direction B) to pull the equipment frame downwards, increasing the inclination [Figure 26].

Operating Angle

Figure 27

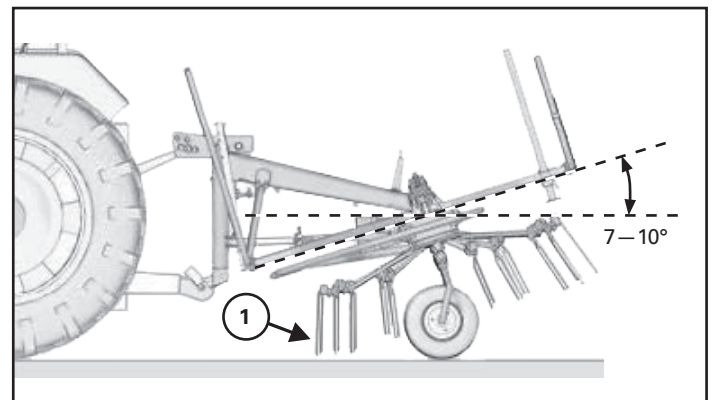

For best results, operate the tedder at an angle of 7–10°. The front tines (Item 1) should graze the ground [Figure 27].

Field Operation

Preliminary information

The hay tedder is an agricultural implement used to spread, aerate, and turn over any type of previously cut forage. This allows early and uniform drying of the product which ensures high-quality forage. Once completely desiccated, it is harvested by a baling process.

Figure 28

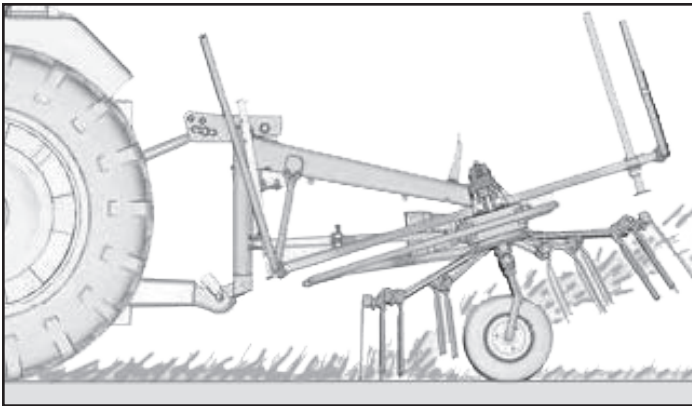

The hay tedder can be of two types: mounted or pull-type. The mounted operates as installed on a tractor equipped with a three-point universal hitch with hydraulic lifter. The pull-type operates as installed to a tractor towing hook.

Both models operate as the tractor pulls them through cut forage. The rotation of the working units, provided by a PTO shaft, aerate and turn over the material [Figure 28].

Before each start-up of the tractor, it is important to follow the precautions described in **"Safety"** on page 9. Remember that the hay tedder is to be used by a qualified operator, of age and trained for its use and operations. Operators must know the instructions in this manual, those reported on the adhesive labels, and all other regulations.

Working Configuration

Connect the tedder to the tractor. See **"Connecting To Tractor"** on page 24 and **"Connecting The PTO Driveline"** on page 27.

Drive the tedder to the work place. See **"Transporting"** on page 35.



IMPORTANT

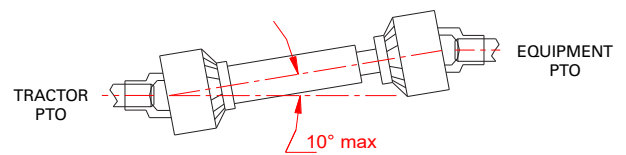

The PTO should not be engaged while the engine is off.

The PTO angle should not exceed 10° when connected to the equipment.

Three-Point Hitch:

- Lower the hydraulic lift until the front tines of the unit skim the soil.
- Adjust the tine inclination with respect to the ground to the correct degree. For any adjustments consult the paragraph **"Tilt Adjustment"** on page 31.
- Place the support foot in the storage position. Follow the instructions described in paragraph **"Connecting To Tractor"** on page 24.

Pull-Type Hitch:

- Adjust the tine inclination with respect to the ground to the correct degree. For any adjustments consult the paragraph **"Tilt Adjustment"** on page 31.

Enter the operator's position of the tractor, start the engine and release the parking brake. Act on the corresponding lever and engage the PTO.

Working process

The aeration process begins as the tractor moves forward with the rotation of the rotary units. The tines skim and scrape the ground, harvesting the cut crop, and spreading the crop rearwards evenly.

Operate for a short distance and then check the result of the process. If the operator deems appropriate to increase or decrease the angle of the rotary groups to improve the working process, adjust as required. See **“Tilt Adjustment”** on page 31

Figure 29

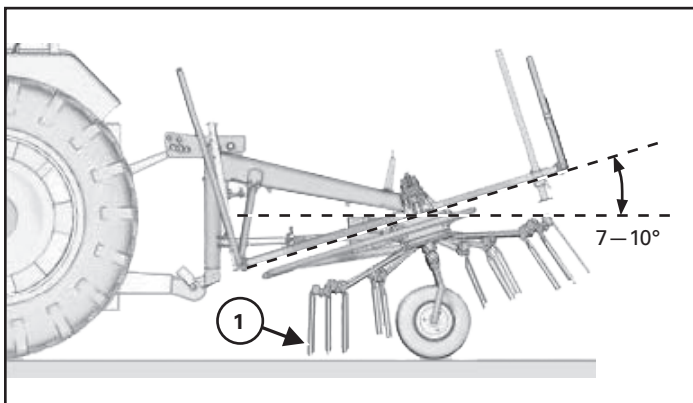

For best results, operate the tedder at an angle of 7–10°. The front tines (Item 1) should graze the ground [Figure 29].

For heavy or damp forage adjust the rotary groups to the maximum inclination (10°).

For light or dry forage adjust the rotary groups to the minimum inclination (7°).

During operations, always maintain the tractor speed within 3–6 mph (5–10 km/h).

Do not exceed the optimum PTO speed of 540 RPM.

! IMPORTANT

Except for cases where otherwise specified, all adjustments must be performed with the tractor engine off, the PTO disengaged, the parking brake pulled and the ignition key removed from the dashboard.

! WARNING



- Do NOT exceed 540 RPM PTO.
- Keep PTO shields and all guards in place.
- Keep away from moving parts.
- Keep bystanders away.

Figure 30

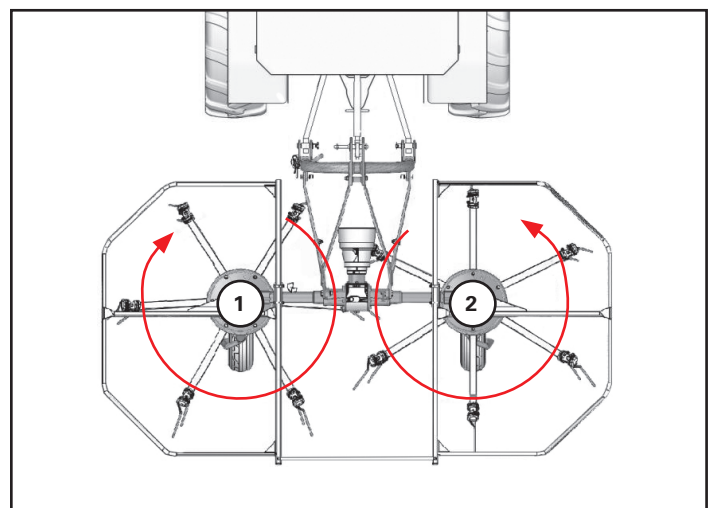

The direction of rotation of the rotary units is as shown. Left unit rotates clockwise (Item 1). Right unit rotates counter-clockwise (Item 2) [Figure 30].

Changing Direction / Reverse

At the end of the field when the tractor and hay tedder must change direction or reverse, it is essential that the tines are lifted from the ground.

Figure 31

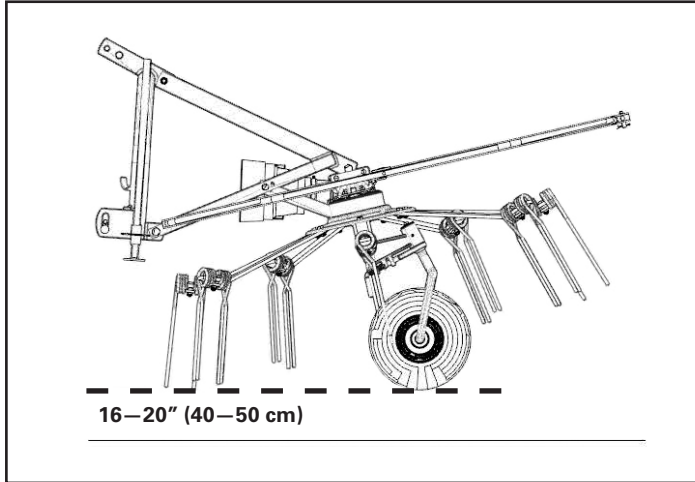

Three-Point Hitch: Act on the tractor hydraulic lift, and raise the equipment about 16–20” (40–50 cm) from the ground [Figure 31].

Figure 32

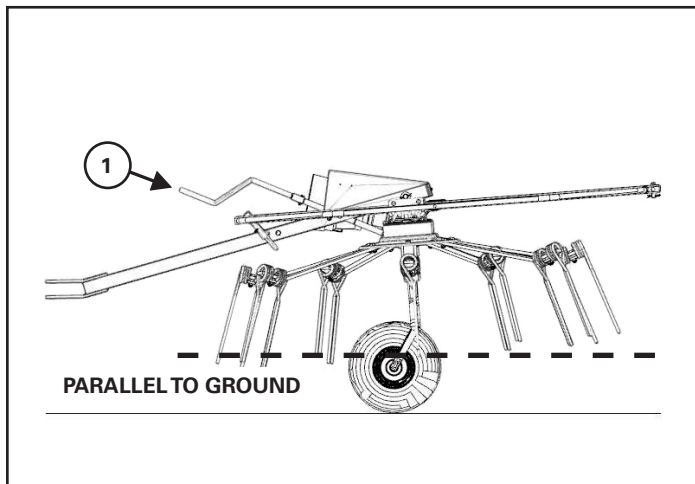

Pull-Type Hitch: Turn the adjustment lever (Item 1) to reset the rotary unit tilt, until parallel with respect to the ground [Figure 32].

Danger Zones

Figure 33

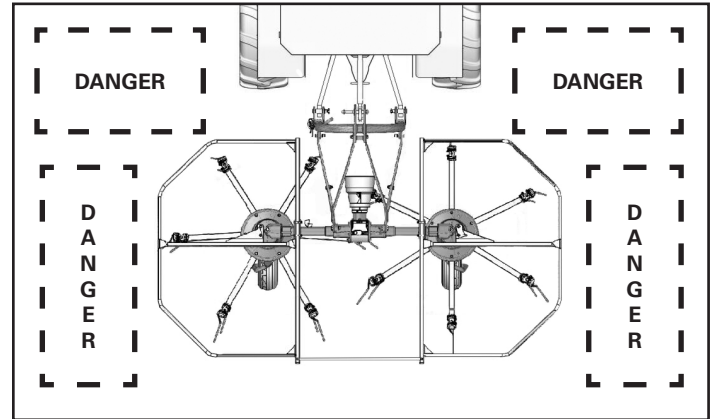

Be careful of danger zones around the equipment [Figure 33].

	WARNING
<p>Clear the work area of all bystanders, especially small children and animals.</p> <p>Clear the work area of all obstacles.</p> <p>Keep shields and all guards in place.</p> <p>Keep away from moving parts.</p>	

Finishing Work

Assume the transport configuration before moving. See “Transporting” on page 35.

Move the tedder to the storage location and perform the following:

- Disengaged the PTO.
- Switch off the tractor engine.
- Engage the parking brake.
- Put the gear lever in neutral position.
- Remove the ignition key from the dashboard.

Transporting

Always comply with federal, state, local and provincial laws regarding the transport of farm equipment on public roadways.

The tines must be lifted sufficiently off the ground during transportation.

Three-Point Hitch: Act on the tractor hydraulic lift, and raise the equipment about 16–20" (40–50 cm) from the ground.

Pull-Type Hitch: Turn the adjustment lever to reset the rotary unit tilt, until parallel with respect to the ground.

	<h1>WARNING</h1>
AVOID INJURY OR DEATH	
<ul style="list-style-type: none"> • Disengage PTO for road travel. • Keep PTO shields and all guards in place • Keep bystanders away. • Do not allow riders. • Always use hazard flashers on the tractor when transporting unless prohibited by law. • Always follow local regulations when transporting on public roadways. Check with your local authorities. 	

	<h1>IMPORTANT</h1>
Do not exceed 20 mph (32 km/h).	

Figure 34

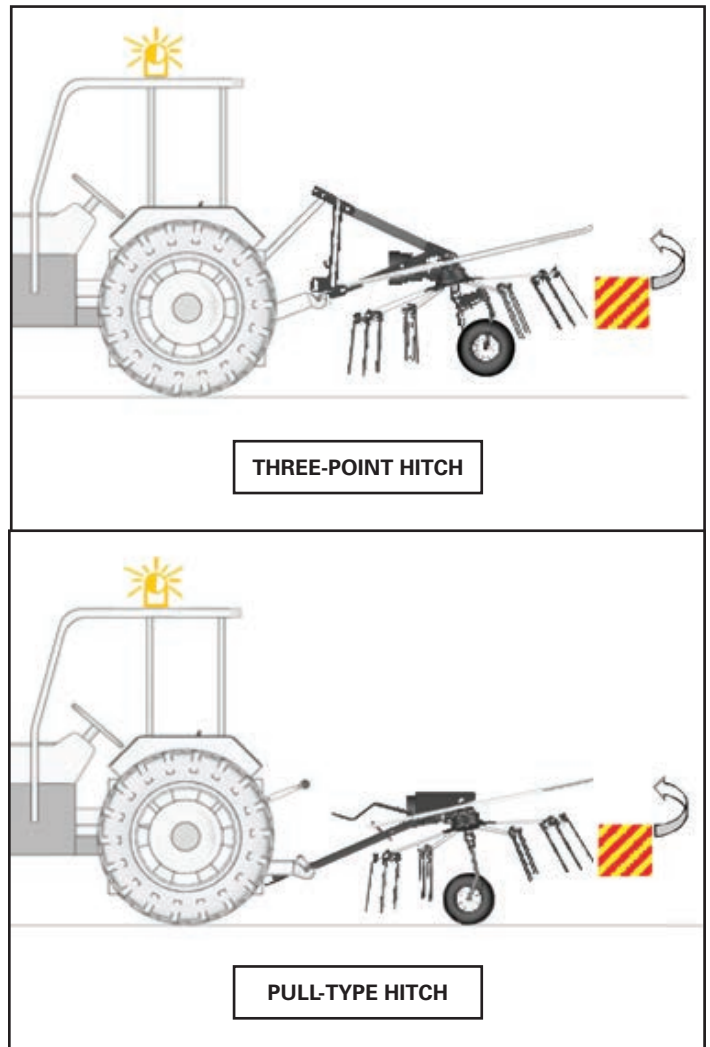

Verify safety chain is installed and properly connected before transporting equipment.

Verify that the SMV (Slow Moving Vehicle) emblem, all lights and reflectors are clean and visible [Figure 34].

	<h1>WARNING</h1>
<p>Use of an unapproved hitch or tractor / tow vehicle can result in loss of control, leading to serious injury or death.</p> <p>Tractor / tow vehicle and hitch must have the rated capacity to tow equipment.</p>	

Verify that the tractor / tow vehicle is approved for transporting the equipment and that the equipment is securely attached to the tractor / tow vehicle.

The ratio of the tractor / tow vehicle weight to the loaded equipment weight plays an important role in defining acceptable travel speed.

TRAVEL SPEED - Acceptable travel speed.

WEIGHT RATIO - Weight of fully equipped or loaded implement(s) relative to weight of tractor / tow vehicle.

Travel Speed	Weight Ratio
20 mph (32 kph)	Less than 1 to 1
10 mph (16 kph)	Less than 2 to 1
DO NOT TOW	More than 2 to 1

Maintenance

Troubleshooting.....	39
Service Schedule Chart.....	40
Lubrication.....	41
Recommendations.....	41
PTO Driveline Grease Locations.....	41
Rotor Grease Locations.....	42
Gearbox.....	43
Checking Gear Oil Level.....	43
Changing Oil.....	43
Cleaning.....	43
Tine Replacement.....	43
Safety And Equipment Signs.....	44
Storage And Return To Service.....	44
Storage.....	44
Return To Service.....	44

Farm King



Troubleshooting

	WARNING
<p>Instructions are necessary before operating or servicing equipment. Read and understand the Operator And Parts Manual and safety signs (decals) on equipment. Follow warnings and instructions in the manuals when making repairs, adjustments or servicing. Check for correct function after adjustments, repairs or service. Untrained operators and failure to follow instructions can cause injury or death.</p>	

If a problem is encountered that is difficult to solve, even after having read through this troubleshooting section, please call your local distributor or dealer. Before you call, please have this Operator And Parts Manual and the serial number of your machine at hand.

PROBLEM	CAUSE	CORRECTION
Partial or insufficient forage harvesting.	Tines too high off the ground.	Adjust working rotary group angle.
Tines rapid wear out.	The tines are continuously in contact with the ground	Adjust working rotary group angle.

Service Schedule Chart

Maintenance work must be done at regular intervals. Failure to do so will result in excessive wear and early failures. The service schedule is a guide for correct maintenance of the equipment.

#	DESCRIPTION	SERVICE PROCEDURES					
		CHECK	CLEAN	LUBE	CHANGE	COVER	DRAIN
Daily Maintenance (every 8 hours of use)							
1	PTO Cross and Bearings			✓			
2	Tines	✓	✓				
BI-Weekly (every 20 hours)							
3	PTO Telescoping Tubes			✓			
4	Shear Pin	✓		✓			
5	PTO Quick Disconnect			✓			
6	PTO Guard Bushings			✓			
Weekly (every 50 hours of use)							
7	Rotors			✓			
8	Three-Point / Pull-Type Hitch	✓					
9	Gearbox	✓		✓			
Annually (every 500 hours of use)							
10	Gearbox (Oil)				✓		✓
11	Entire Machine		✓				

Lubrication

Recommendations

Always use a good quality multi-purpose / lithium base grease when lubricating the equipment.

!

IMPORTANT

Do not over-grease bearings. Greasing too often can damage seals and lead to premature bearing failure.

- Always use a hand-held grease gun.
- Clean fitting before greasing, to avoid injecting dirt and grit.
- Replace and repair broken fittings immediately.
- If fittings will not take grease, remove and clean thoroughly. Replace fitting if necessary.

!

WARNING

AVOID INJURY OR DEATH

Stop engine, set brake, remove ignition key, and wait for all moving parts to stop before servicing, adjusting, repairing, or unplugging.

Support the equipment with blocks or safety stands before working beneath it.

Follow good shop practices:

- Keep service area clean and dry
- Be sure electrical outlets and tools are properly grounded
- Use adequate light for the job.

Use only tools, jacks, and hoists of sufficient capacity for the job. Replace and secure all shields removed during servicing before operating.

Use heavy leather gloves to handle sharp objects.

PTO Driveline Grease Locations

!

IMPORTANT

Fluid such as engine oil, hydraulic fluid, coolants, grease, etc. must be disposed of in an environmentally safe manner. Some regulations require that certain spills and leaks on the ground must be cleaned in a specific manner. See local, state and federal regulations for the correct disposal.

Figure 35

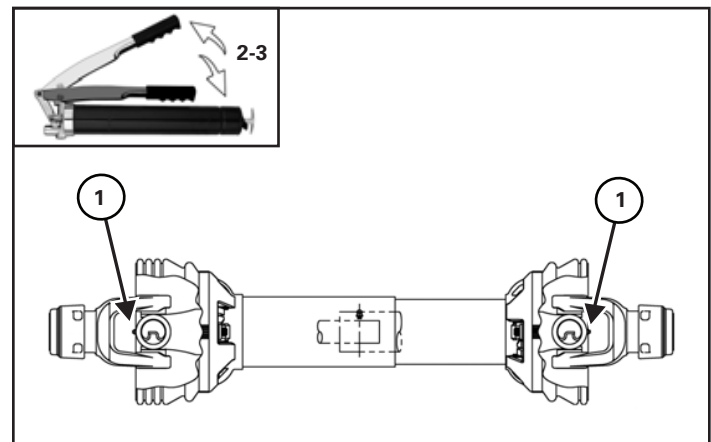

Apply two to three pumps of grease to the cross and bearings (Item 1) on the PTO driveline [Figure 35].

Grease every **8 hours**.

NOTE: Images may not show your exact PTO driveline but the procedure is correct.

Figure 36

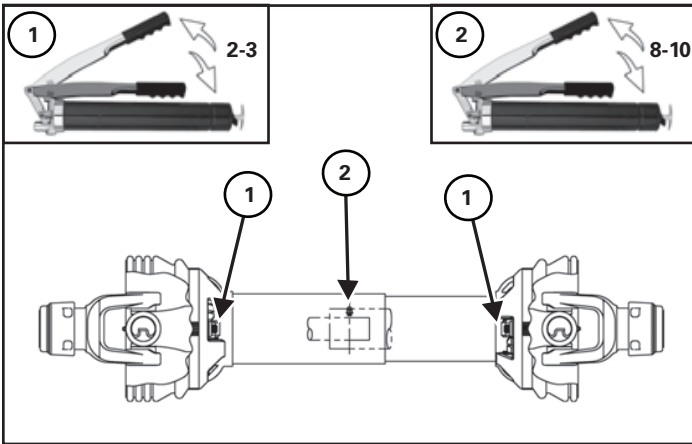

Apply two to three pumps of grease to the guard bushings (Item 1) [Figure 36].

Apply eight to ten pumps of grease to the telescoping member (Item 2) [Figure 36].

Grease every **20 hours**.

Figure 37

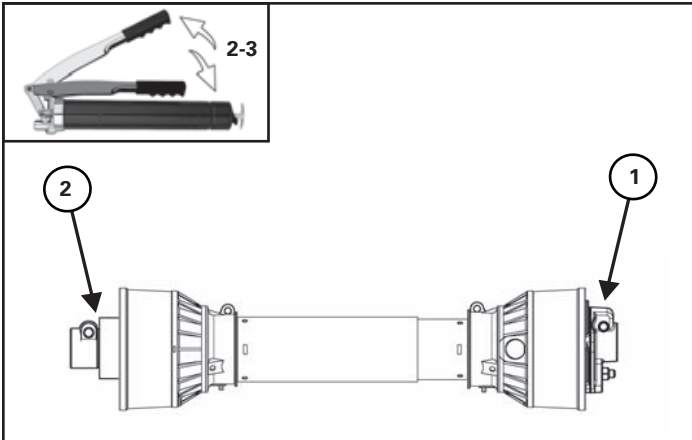

Apply two to three pumps of grease to the shear pin (Item 1) and PTO quick disconnect (Item 2) [Figure 37].

Grease every **20 hours**.

Rotor Grease Locations

Figure 38

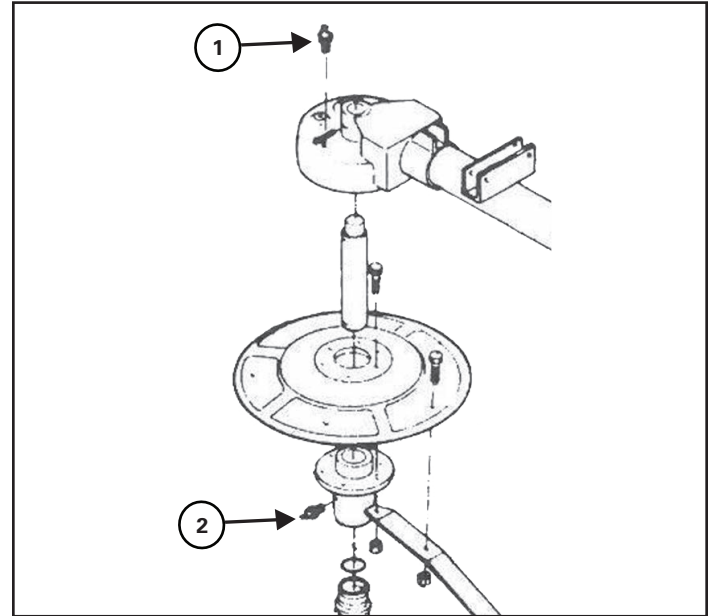

Apply grease to the rotor groups (Item 1) and spindle couplings (Item 2) [Figure 38].

Grease every **50 hours**.

Gearbox

Checking Gear Oil Level

Figure 39

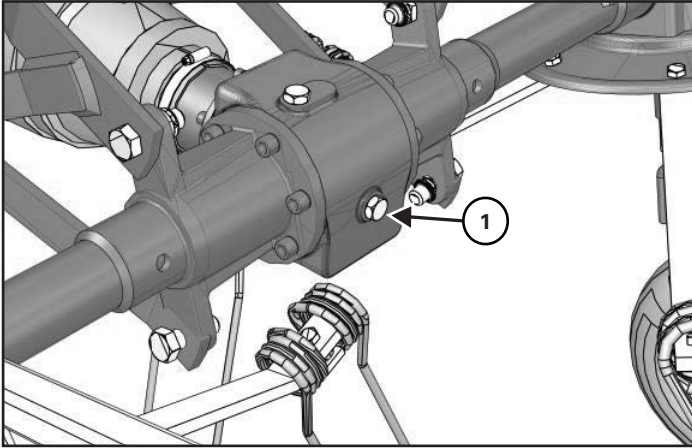

Park the tractor and equipment on a flat level surface.

	<h1 style="margin: 0;">IMPORTANT</h1>
<p>Allow gear oil to settle into the bottom cavity of the gearbox for approximately 15-20 min. before checking level.</p>	

Remove check plug (Item 1). Oil level should be at the bottom edge of the plug [Figure 39].

Check every **50 hours**.

Changing Oil

Refill oil through the check plug until oil begins to overflow. Reinstall plug [Figure 39].

Use ISO VG 320 gear oil.

Cleaning

Fully clean the equipment.

Keep equipment free of any debris. Remove buildup from tines.

Tine Replacement

Figure 40

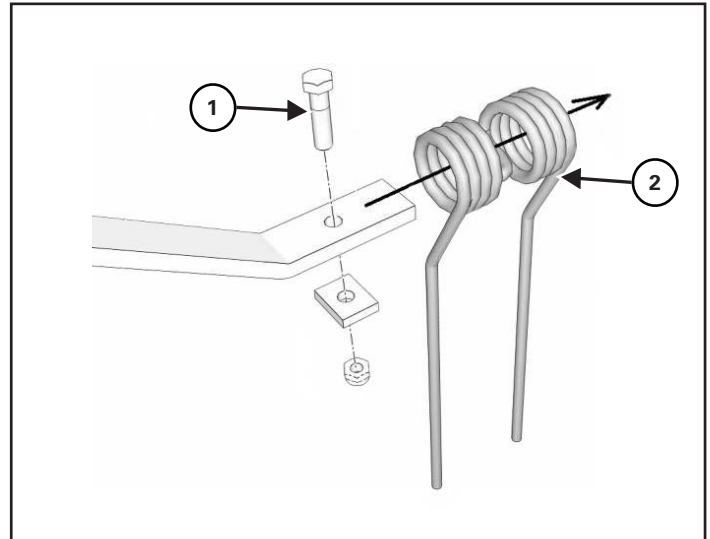

Replace tines if found to be worn or broken.

Remove the locking nut, clamp, and screw (Item 1). Pull the tine pair (Item 2) from the rotor arm [Figure 40].

Install a new tine pair and reattach hardware.

Figure 41

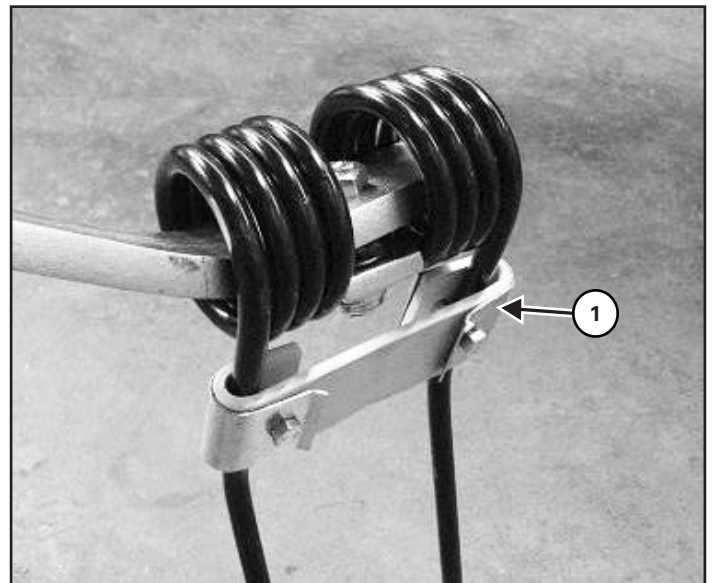

Install the tine-holder clamp (optional) (Item 1) for added protection. Position above the bend in the tine pair. Secure with screws and locking nuts [Figure 41].

Safety And Equipment Signs

Remove all portions of the damaged safety sign (decal).

Thoroughly clean the area with glass cleaner.

Removing all adhesive residue.

Allow the area to dry completely before installing the new safety sign (decal).

Position the safety sign (decal) in the correct location.

Remove a small portion of the backing paper on the safety sign (decal).

Press on the safety sign (decal) where the backing paper has been removed.

Slowly remove the remaining backing paper, pressing on the safety sign (decal) as the backing paper is removed.

Using the backing paper, pressing firmly, move the backing paper over the entire safety sign (decal) area.

NOTE: Small air pockets can be pierced with a pin and smoothed out using the piece of the backing paper.



IMPORTANT

When replacing safety signs (decals), the temperature must be above 10° C (50° F).

Storage And Return To Service

Storage

Sometimes it may be necessary to store the equipment for an extended period of time. Below is a list of items to perform before storage.

Thoroughly clean the equipment.

Inspect the hitch and all welds on the equipment for wear and damage. Check for loose hardware, missing guards, or damaged parts.

Check for damaged or missing safety signs (decals). Replace if necessary.

Replace worn or damaged parts. Touch up all paint nicks and scratches to prevent rusting.

Place the equipment in a dry protected shelter.

NOTE: If a dry protected shelter is not available, cover with a waterproof tarp and tie down securely.

Place the equipment flat on the ground. Place planks under support stand if required.

Return To Service

After the equipment has been in storage, it is necessary to follow a list of items to return the equipment to service.

Be sure all shields and guards are in place.

Connect to a tractor and operate equipment, verify all functions operate correctly.



IMPORTANT

DO NOT permit children to play on or around the stored machine.

Parts Identification

General Parts Information.....	47
Guards.....	47
Pull-Type Hitch.....	48
Three-Point Hitch.....	50
Main Components.....	52
Driveline.....	56
PTO - Pull-Type Hitch - 8020436.....	58
PTO - Three-Point Hitch - 8020435.....	59
Decal Kit.....	60

Farm King



General Parts Information

The parts identification section lists the descriptions, part numbers, and quantities for all North American base model RT10 Tedders. Contact your Farm King dealer for additional parts information.

Guards

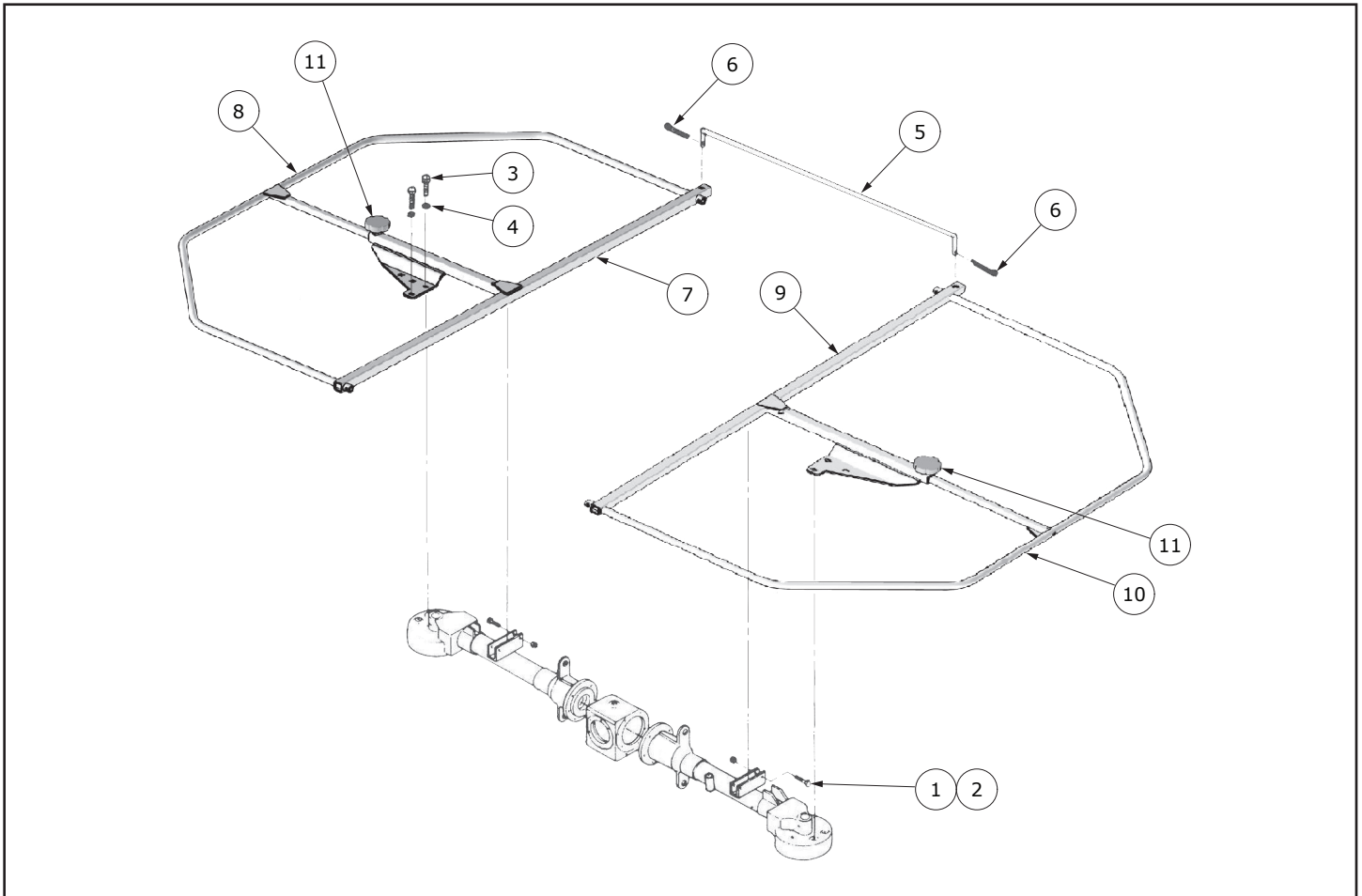

ITEM	PART NUMBER	DESCRIPTION
1	R3011246	SCREW TE 10 X 50
2	R3020201	SELF-LOCKING NUT M10
3	R3011211	HH SCREW 10 X 25 5739
4	R3030159	WASHER M10
5	R18031119	PROTECTION GUARD ROD
6	R3040201	COTTER PIN 3 X 60
7	R18031501	R FIXED PROTECTION GUARD
8	R18031832	R MOBILE PROTECTION GUARD
9	R18031502	L FIXED PROTECTION GUARD
10	R18031833	L MOBILE PROTECTION GUARD
11	R3140023	ADJUST HANDLE M12 X 40

Pull-Type Hitch

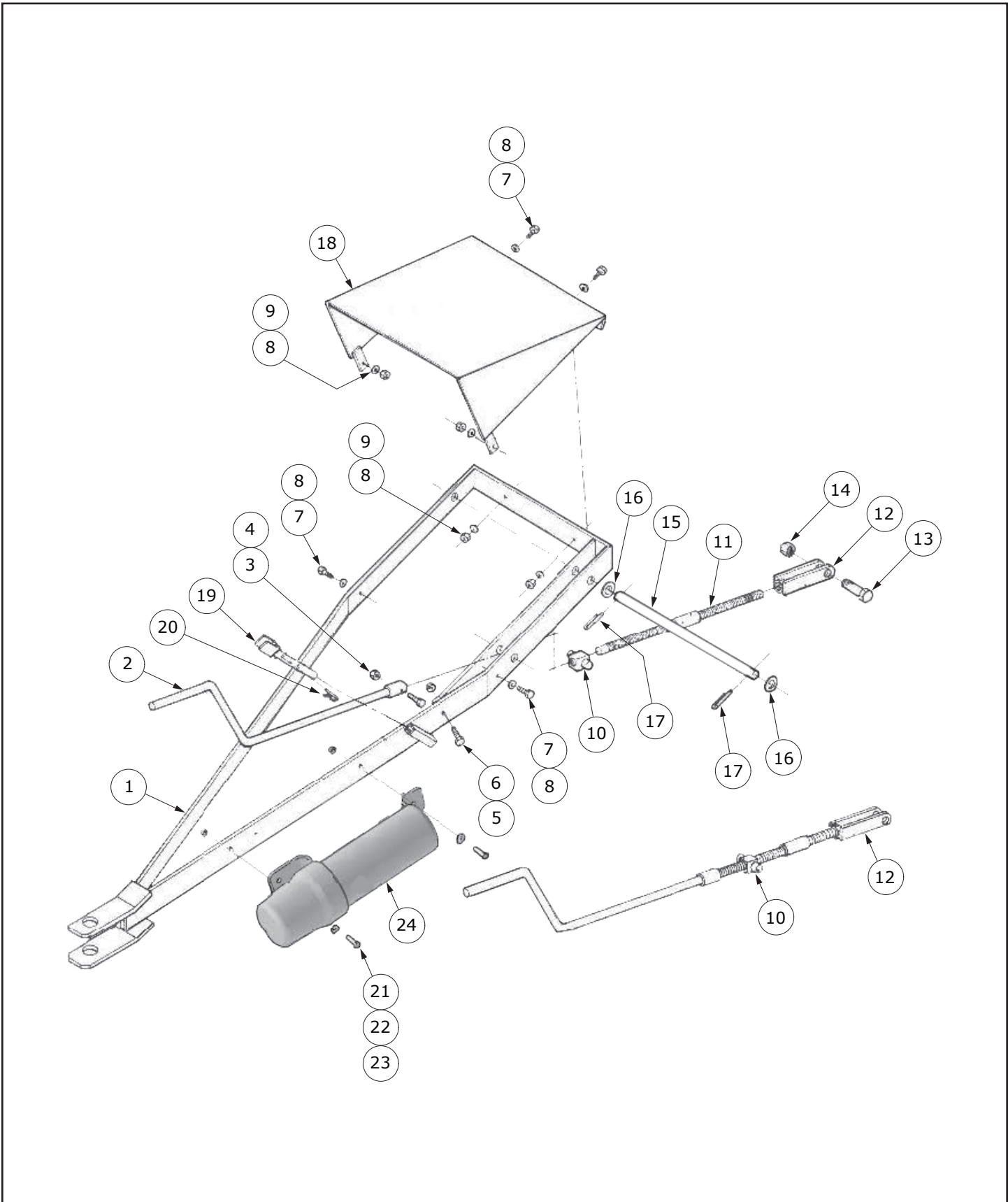

ITEM	PART NUMBER	DESCRIPTION
1	R18030651	DRAWBAR
2	R18030652	CRANK
3	R3011252	SCREWTE 8 X 35
4	R3020209	SELF LOCKING NUT 8 MA
5	R3011216	SCREWTE 12 X 35 UNI 5737
6	R3020202	SELF LOCKING NUT M12
7	R3011601	SCREWTE 6 X 25
8	R3030160	WASHER 6 X 18
9	R3020213	SELF LOCKING NUT 6 MA
10	R12070316	SPLIT NUT 20 MA LEFT
11	R2760118	THREADED TIE ROD 20 MA (R&L)
12	R18030653	FORK
13	R3011299	SCREWTE 20 X 70
14	R3020216	SELF LOCKING NUT 20 MA
15	R18030654	DRAWBAR ROD
16	R3030134	WASHER 20
17	R3040103	ROLL PIN 4 X 40
18	R18030665	DRAWBAR CASING
19	R18030691	CRANK HOLDER
20	R3040201	CLIP PIN 3 X 60
21	R3020213	SELF LOCKING NUT M6
22	R3030160	WASHER M6
23	R3011601	H.H. SCREW M6 X 25
24	R9080022	MANUAL HOLDER

Three-Point Hitch

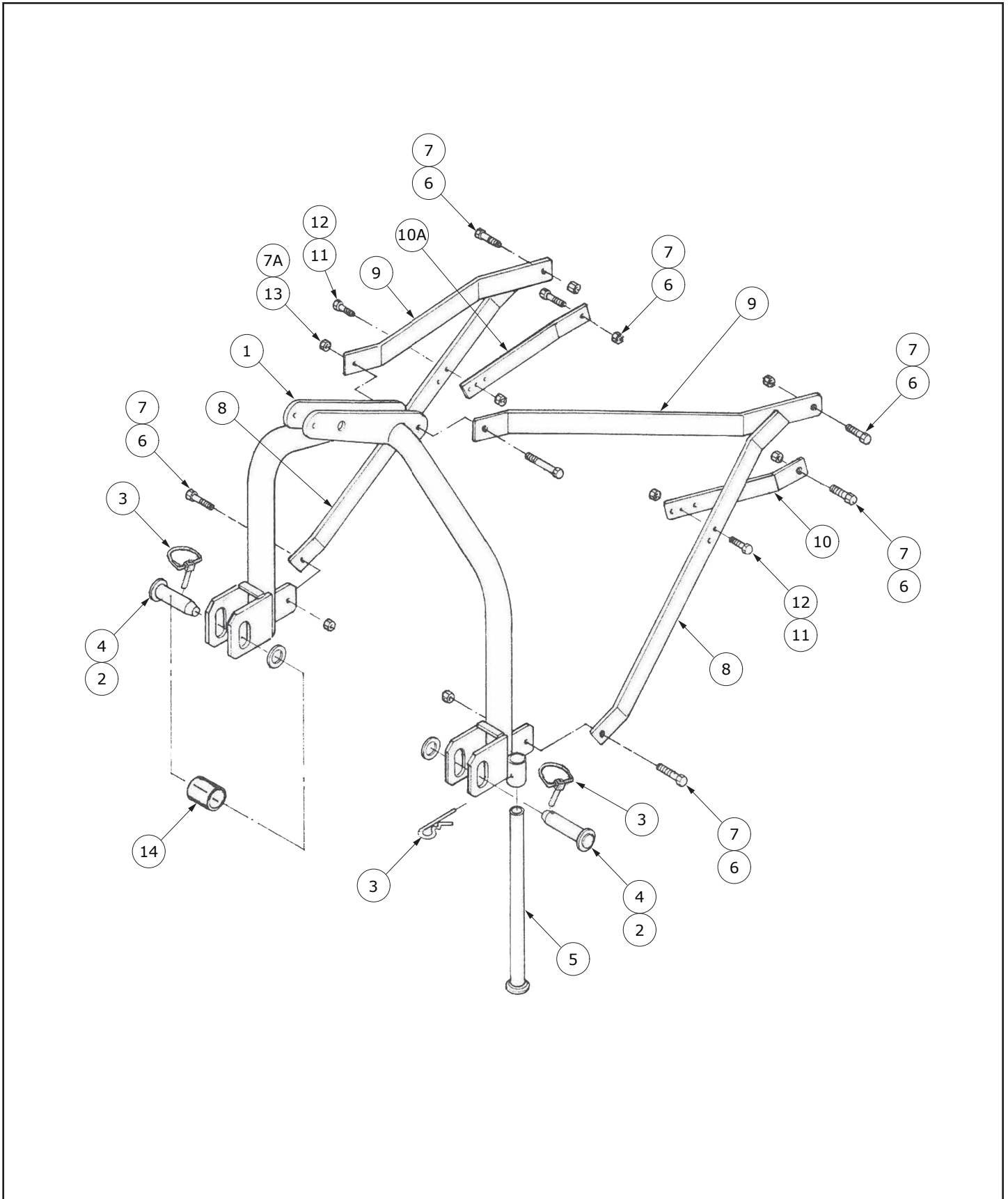

ITEM	PART NUMBER	DESCRIPTION
1	R18030646	TRANSPORT FRAME
2	R12880513	HITCH PIN
3	R3080202	SAFETY PIN
4	R3030176	FLAT WASHER 22
5	R18030647	SUPPORT LEG L. 710
6	R3011218	PIN 18 X 55
7	R3020214	SELF LOCKING NUT 18 MA
7A	R3020204	SELF LOCKING NUT 18 MA
8	R18030648	LEFT LINK BAR
9	R18030649	RIGHT LINK BAR
10	R18030650	HEIGHT ADJUSTMENT BAR LEFT
10A	R18030617	HEIGHT ADJUSTMENT BAR RIGHT
11	R3011632	SCREWTE 14 X 45
12	R3020203	SELF LOCKING NUT 14 MA
13	R3010405	SCREWTE 16 X 120
14	R12920101	SCREWTE 16 X 120

Main Components

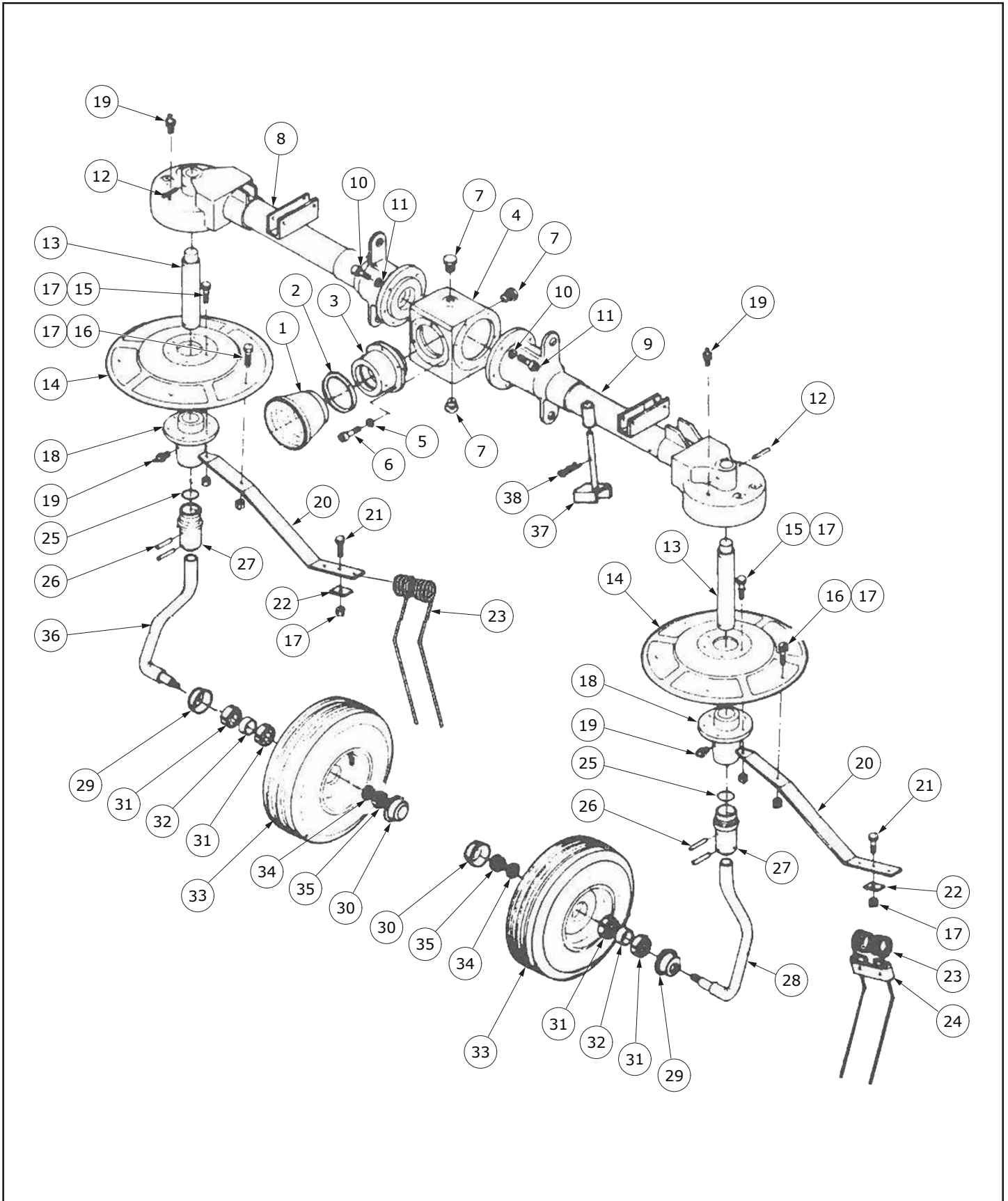

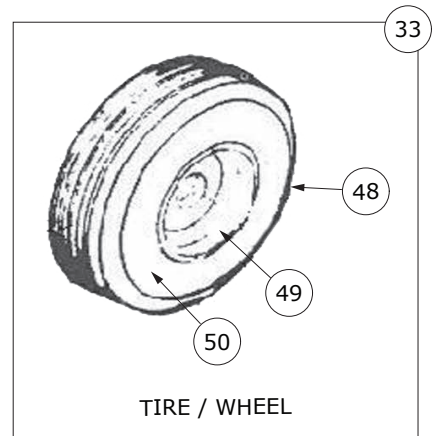
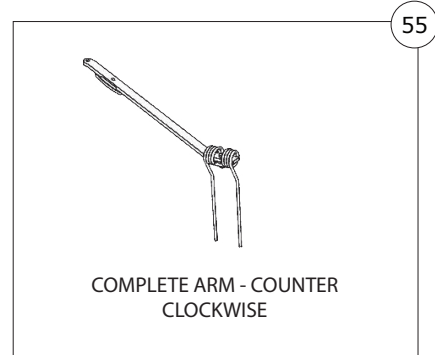
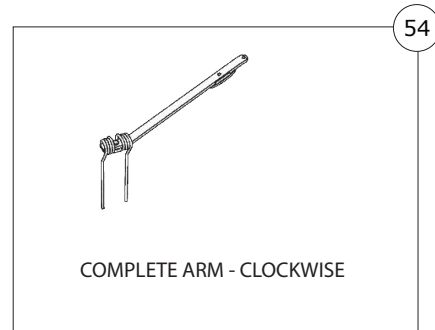
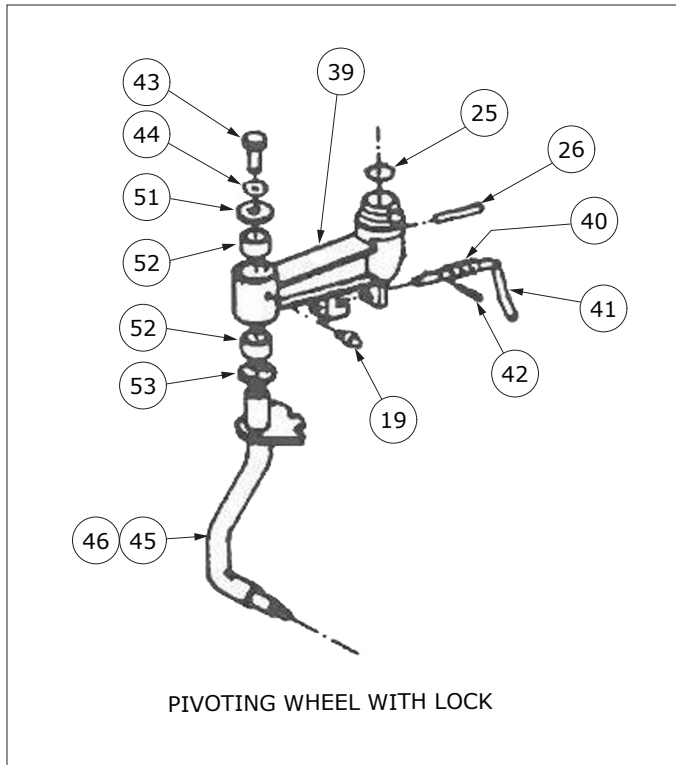

ITEM	PART NUMBER	DESCRIPTION
1	R9070101	PROTECTION GUARD
2	R4010702	CLAMP 80 ÷ 100
3	R18030657	CENTRAL GEAR BOX COUPLING
4	R18030623	CENTRAL GEAR BOX 180
5	R3030704	SCHNOR WASHER 0 8
6	R3010606	SCREW T.C.C.E.I. M 8 X 20
7	R4010822	CONICAL PLUG 3/8"
8	R18030659	RIGHT ARM
9	R18030661	LEFT ARM
10	R3030703	LOCK WASHER 0 12
11	R3010607	SCREW T.C.C.E.I. M 12 X 25
12	R3080129	ROLL PIN 10 X 70
13	R12060901	TERMINAL PIN 35 X 240
14	R18030643	ARM. LINKAGE FLANGE
15	R3010601	SCREW T.C.C.E.I. 12 X 50
16	R3011215	SCREW TE 12 X 40 ZN
17	R3020202	SELF-LOCKING NUT M12
18	R18030619	CROWN COUPLING
19	R3090101	GREASER 8 MB
20	R18034998	SPRING HOLDER ARM
21	R3011297	SCREW TE 12 X 45 ZN
22	R18030627	SPRING CLAMP
23	R18030616	SPRING
24	R18030644	TOOTH SAFETY CLAMP (OPTIONAL)
25	R10010604	O-RING 44,45 X 3,53
26	R3080128	SPRING PIN 0 10 X 60
27	R12880509	FIXED WHEEL AXLE BUSH
28	R18030625	FIXED WHEEL AXLE
29	R12070314	INTERNAL DUST SHIELD 25
30	R12070315	EXTERNAL DUST SHIELD 16
31	R12240113	BEARING 6205 2RS
32	R12070307	SPACER 0 25
33	R12170103	COMPLETE WHEEL 15 - 600 - 6 (INCLUDES ITEM 54, 55, 56)
34	R3030175	WASHER 16
35	R3020204	SELF-LOCK. NUT 16 MA
36	R18030663	RIGHT WHEEL AXLE
37	R18030637	ROTORS LOCK
38	R3040201	CLIP PIN 3 X 60
39	R18031103	PIVOT WHEEL ATTACHMENT
40	R11010603	SPRING
41	R12880504	LOCKING HANDLE

ITEM	PART NUMBER	DESCRIPTION
42	R3080103	SPRING PIN 6 X 40
43	R3011211	HH SCREW 10 X 25 5739
44	R3030159	WASHER M10
45	R18031101	CRAZY WHEEL AXLE R.
46	R18031102	CRAZY WHEEL AXLE L.
47	R18031103	COMPLETE PIVOTING WHEEL ATTACHMENT
48	R12070313	TIRE 15.600.6
49	R12070311	WHEEL RIM
50	R12070312	AIRTUBE 15.600.6
51	R18031104	WASHER 55 - 11 - 6
52	R12240152	GLYCODUR BEARING 30 X 34 X 30 F
53	R12280203	GLYCODUR WASHER 32 X 54 X 45
54	R18034997	COMPLETE ARM - CLOCKWISE
55	R18034999	COMPLETE ARM - COUNTERCLOCKWISE
-	R18031103	COMPLETE PIVOTING WHEEL ATTACHMENT (INCLUDES ITEM 19, 44, 45, 46, 47, 59)

Driveline

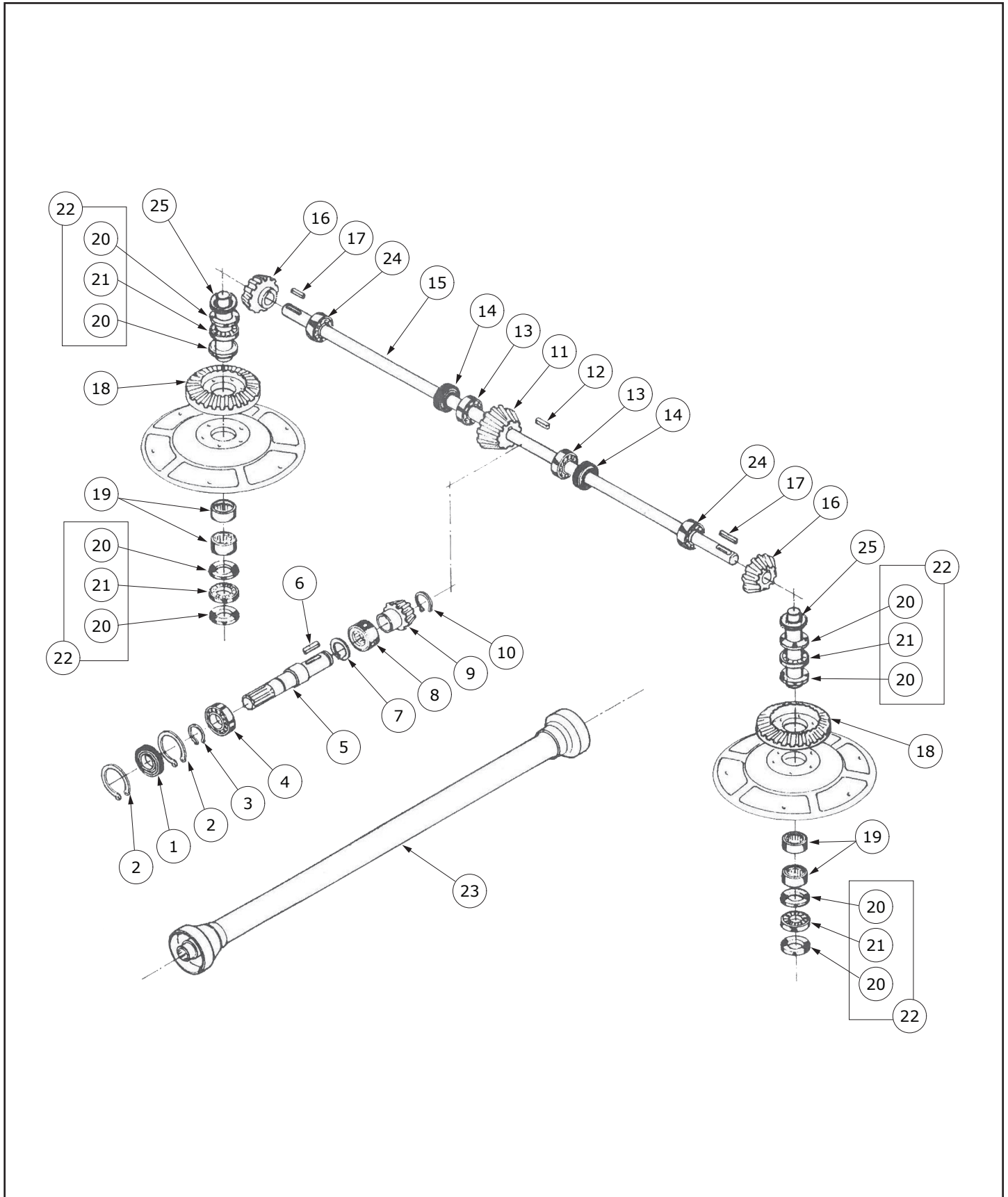

ITEM	PART NUMBER	DESCRIPTION
1	R12260003	OIL SEAL 35.72.10
2	R3120105	SNAP RING I 72-7437-75
3	R3120102	SNAP RING E 35-7435-75
4	R12240109	BEARING 6207
5	R12320301	SHAFT FOR PTO
6	R3110003	KEY 8X7X40
7	R3120120	SPRING RING BR 52 INA
8	R12070302	ROLLER BUSH HK 4520
9	R8010302	BEVEL PINION GEAR Z16
10	R3120101	SNAP RING E 30-7435-75
11	R8010304	RING BEVEL GEAR Z23
12	R3110002	KEY 8X7X35
13	R12240108	BEARING 6206 RS
14	R12260002	OIL SEAL 30.55.10
15	R12010202	CENTRAL SHAFT
16	R8010303	BEVEL PINION Z17
17	R3110001	KEY 8X7X25
18	R18030655	RING BEVEL GEAR Z34
19	R12070301	ROLLER BUSH HK 3520
20	R12280001	AXLE THRUST BEARING AS 3552
21	R12270001	AXIAL HOUSING AXK 3552
22	R18030656	COMPLETE AXLE CAGE (AXK + AS) (INCLUDES ITEM 20, 21)
23	R8020436	PTO SHAFT (PULL TYPE HITCH)
	R8020435	PTO SHAFT (THREE-POINT HITCH)
24	R12240102	TAPER ROLLER BEARING 6006
25	R3120126	FLAT WASHER FROM 0,3 TO 0,5 MM

PTO - Pull-Type Hitch - 8020436

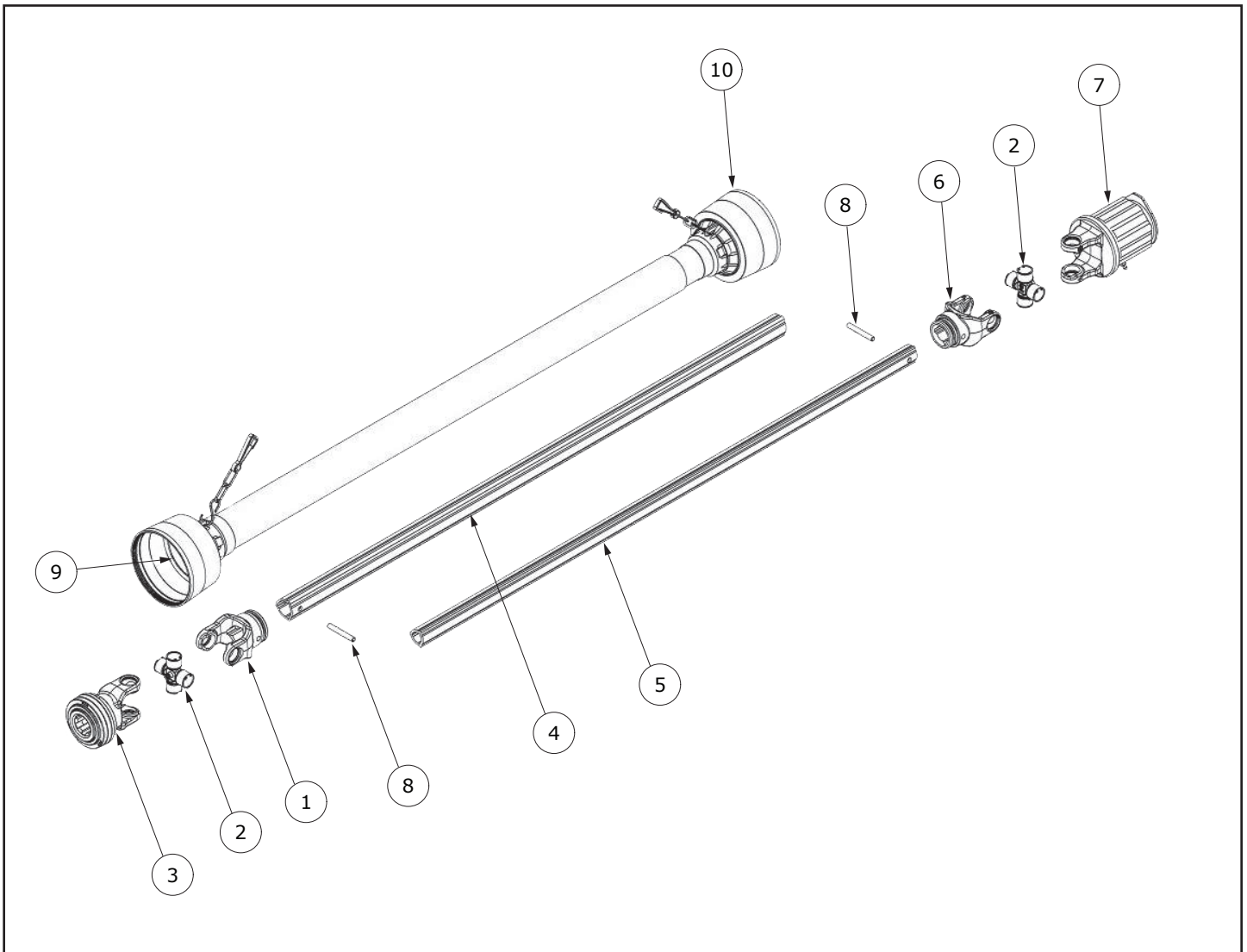

ITEM	PART NUMBER	DESCRIPTION
1	R12881476	TRIANGULAR FORK
2	R12881477	COMPLETE CROSS
3	R12881478	FORK SPLINED 1.3/8" Z6
4	R12881479	TUBE EXT. L.885
5	R12881480	TUBE INT. L.885
6	R12881481	INTERNAL TRIANGULAR FORK
7	R12881527	LIMITING 2 G. 1.3/8" Z6
8	R12881483	ELASTIC PIN 8X55 DIN 1481
9	R12881484	EXTERNAL PROTECTION L.1010 - 1/2
10	R12881485	INTERNAL PROTECTION L.1010 - 1/2

PTO - Three-Point Hitch - 8020435

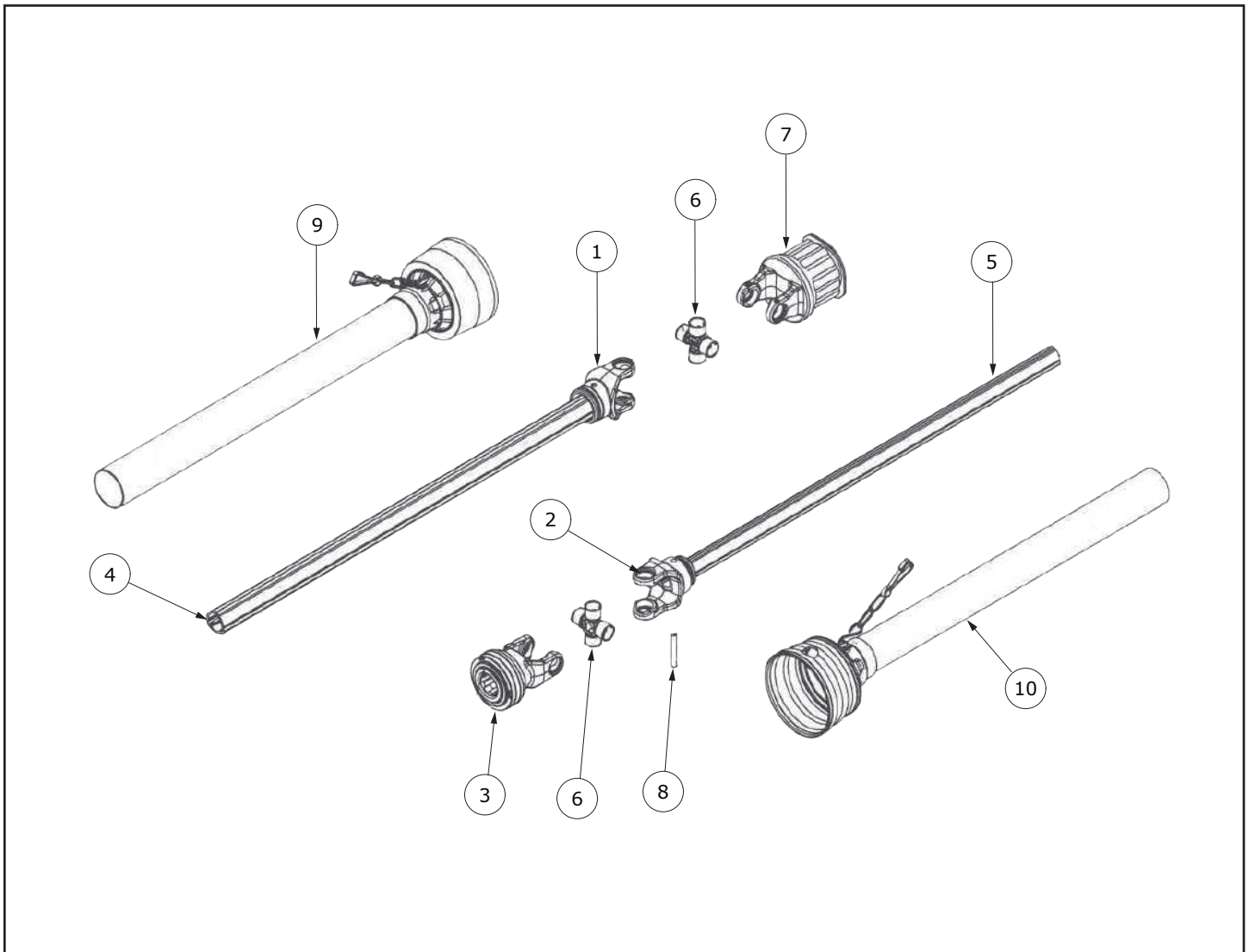

ITEM	PART NUMBER	DESCRIPTION
1	R12881545	EXTERNAL TRIANGULAR FORK
2	R12881546	INTERNAL TRIANGULAR FORK
3	R12881478	FORK SPLINED 1.3/8" Z6
4	R12881547	TUBE EXT.
5	R12881548	TUBE INT.
6	R12881549	COMPLETE CROSS
7	R12881527	LIMITING 2 G. 1.3/8" Z6
8	R12881483	ELASTIC PIN 8X55 DIN 1481
9	R12881550	EXTERNAL PROTECTION - 1/2
10	R12881551	INTERNAL PROTECTION - 1/2

Decal Kit

ITEM	PART NUMBER	DESCRIPTION
1	R9270207	KIT OF EU ADHESIVE LABELS (SAFETY AND EQUIPMENT DECALS)

Specifications And Shipping Kit Numbers

Specifications.....	63
Shipping Kit And Bundle Numbers.....	64
Hardware Torque Values.....	65
Metric Chart.....	65
Imperial Chart.....	66

Farm King



Specifications

Specifications	Three-Point Hitch	Pull-Type Hitch
Working width	10.2 ft (310 cm)	10.2 ft (310 cm)
Transport width	8.2 ft (250 cm)	8.2 ft (250 cm)
Tine holder arms	12	12
Tines	12	12
PTO speed	540 rpm	540 rpm
Tractor power	20 hp	20 hp
Tractor working speed	3–6 mph (5–10 km/h)	3–6 mph (5–10 km/h)
Tires	2	2
Weight	419 lbs (190 kg)	425 lbs (193 kg)

Shipping Kit And Bundle Numbers

The following is a list of Kit Numbers for this product and the Bundle Numbers, Descriptions, and Quantities for each Kit.

Qty.	Bundle	Description
10' Three-Point Tedder w/Slip Clutch, Flo Tires		
1	RT10PTFK	Complete Assembly
10' Pull Tedder w/Slip Clutch, Flo Tires		
1	RT210PMFK	Complete Assembly

Hardware Torque Values

Metric Chart

NOTE: Do not use the values listed in the charts if a different torque value or tightening procedure is specified in this manual for a specific application. Torque values listed are for general use only.

Use the following charts to determine the correct torque when checking, adjusting or replacing hardware. **Torque values are listed in newton-meters (inch* or foot pounds) for normal assembly applications.**

Nominal Size	Class 5.8		Class 8.8		Class 10.9		Lock nuts
	Unplated	Plated W / ZnCr	Unplated	Plated W / ZnCr	Unplated	Plated W / ZnCr	CL.8 W/ CL. 8.8 Bolt
M4	1.7 (15*)	2.2 (19*)	2.6 (23*)	3.4 (30*)	3.7 (33*)	4.8 (42*)	1.8 (16*)
M6	5.8 (51*)	7.6 (67*)	8.9 (79*)	12 (102*)	13 (115*)	17 (150*)	6.3 (56*)
M8	14 (124*)	18 (159*)	22 (195*)	28 (248*)	31 (274*)	40 (354*)	15 (133*)
M10	28 (21)	36 (27)	43 (32)	56 (41)	61 (45)	79 (58)	30 (22)
M12	49 (36)	63 (46)	75 (55)	97 (72)	107 (79)	138 (102)	53 (39)
M16	121 (89)	158 (117)	186 (137)	240 (177)	266 (196)	344 (254)	131 (97)
M20	237 (175)	307 (226)	375 (277)	485 (358)	519 (383)	671 (495)	265 (195)
M24	411 (303)	531 (392)	648 (478)	839 (619)	897 (662)	1160 (855)	458 (338)

NOTE: Torque values shown with * are inch pounds.

Identification of Hex Cap Screws and Carriage Bolts - Classes 5 and up

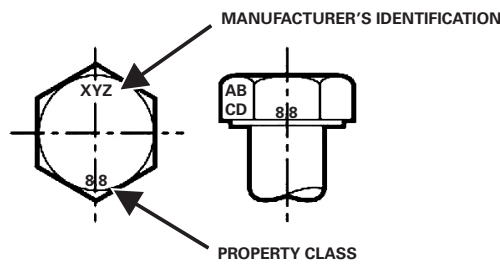

Identification of Hex Nuts and Lock Nuts - Classes 5 and up

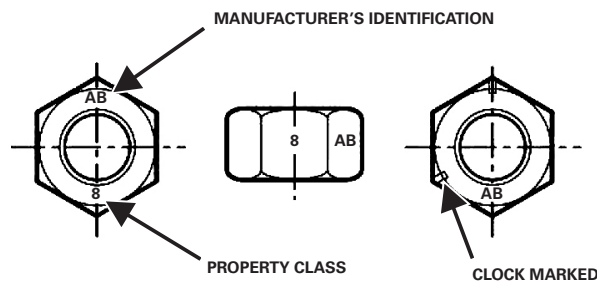

Hardware Torque Values (Cont'd)

Imperial Chart

NOTE: Do not use the values listed in the charts if a different torque value or tightening procedure is specified in this manual for a specific application. Torque values listed are for general use only.

Use the following charts to determine the correct torque when checking, adjusting or replacing hardware. Torque values are listed in newton-meters (inch* or foot pounds) for normal assembly applications.

Nominal Size	SAE Grade 5		SAE Grade 8		LOCK NUTS			
	Unplated or Plated Silver	Plated W / ZnCr Gold"	Unplated or Plated Silver	Plated W / ZnCr Gold"	Unplated or Plated Silver	Plated W / ZnCr Gold"	Grade W / Gr. 5 Bolt	Grade W / Gr. 8 Bolt
1/4	6.2 (55*)	8.1 (72*)	9.7 (86*)	12.6 (112*)	13.6 (121*)	17.7 (157*)	6.9 (61*)	9.8 (86*)
5/16	13 (115*)	17 (149*)	20 (178*)	26 (229*)	28 (250*)	37 (324*)	14 (125*)	20 (176*)
3/8	23 (17)	30 (22)	35 (26)	46 (34)	50 (37)	65 (48)	26 (19)	35 (26)
7/16	37 (27)	47 (35)	57 (42)	73 (54)	80 (59)	104 (77)	41 (30)	57 (42)
1/2	57 (42)	73 (54)	87 (64)	113 (83)	123 (91)	159 (117)	61 (45)	88 (64)
9/16	81 (60)	104 (77)	125 (92)	163 (120)	176 (130)	229 (169)	88 (65)	125 (92)
5/8	112 (83)	145 (107)	174 (128)	224 (165)	244 (180)	316 (233)	122 (90)	172 (127)
3/4	198 (146)	256 (189)	306 (226)	397 (293)	432 (319)	560 (413)	217 (160)	306 (226)
7/8	193 (142)	248 (183)	495 (365)	641 (473)	698 (515)	904 (667)	350 (258)	494 (364)
1	289 (213)	373 (275)	742 (547)	960 (708)	1048 (773)	1356 (1000)	523 (386)	739 (545)

NOTE: Torque values shown with * are inch pounds.

Identification of Hex Cap Screws and Carriage Bolts



GRADE 2
SAE BOLT



GRADE 5
SAE BOLTS



GRADE 8
SAE BOLTS



GRADE 2
SAE NUTS



GRADE 5
SAE NUTS



GRADE 8
SAE NUTS

Identification of Hex Nuts and Lock Nuts

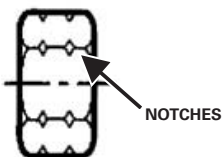

GRADE IDENTIFICATION

GRADE A: NO NOTCHES

GRADE B: ONE CIRCUMFERENTIAL NOTCH

GRADE C: TWO CIRCUMFERENTIAL NOTCHES

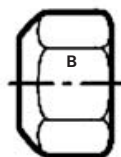

GRADE IDENTIFICATION

GRADE A: NO MARK

GRADE B: LETTER B

GRADE C: LETTER C

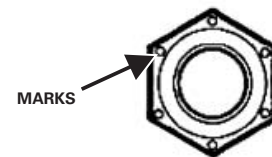

GRADE IDENTIFICATION

GRADE A: NO MARKS

GRADE B: THREE MARKS

GRADE C: SIX MARKS

MARKS NEED NOT BE LOCATED AT CORNERS

Warranty

Farm King Base Limited Warranty.....	69
Repair Parts Limited Warranty.....	69
What Is Not Covered.....	69
Authorized Dealer And Labor Costs.....	69
Warranty Requirements.....	70
EXCLUSIVE EFFECT OF WARRANTY AND LIMITATION OF LIABILITY.....	70

Farm King



Farm King Base Limited Warranty

Farm King provides this warranty only to original retail purchasers of its products. Farm King warrants to such purchasers that all Farm King manufactured parts and components used and serviced as provided for in the Operator's Manual shall be free from defects in materials and workmanship for a period following delivery to the original retail purchaser of one (1) year. This limited warranty applies only to those parts and components manufactured by Farm King. Parts and components manufactured by others are subject to their manufacturer's warranties, if any.

Farm King will fulfill this limited warranty by, at its option, repairing or replacing any covered part that is defective or is the result of improper workmanship, provided that the part is returned to Farm King within thirty (30) days of the date that such defect or improper workmanship is, or should have been, discovered. Parts must be returned through the selling representative and the buyer must prepay transportation charges.

Farm King will not be responsible for repairs or replacements that are necessitated, in whole or part, by the use of parts not manufactured by or obtained from Farm King. Under no circumstances are component parts warranted against normal wear and tear. There is no warranty on product pump seals, product pump bearings, rubber product hoses, pressure gauges, or other components that require replacement as part of normal maintenance.

Repair Parts Limited Warranty

Farm King warrants genuine Farm King replacement parts purchased after the expiration of the Farm King Limited Warranty, and used and serviced as provided for in the Operator's Manual, to be free from defects in materials or workmanship for a period of thirty (30) days from the invoice date for the parts. Farm King will fulfill this limited warranty by, at its option, repairing or replacing any covered part that is defective or is the result of improper workmanship, provided that the part is returned to Farm King within thirty (30) days of the date that such defect or improper workmanship is, or should have been, discovered. Such parts must be shipped to the Farm King factory at the purchaser's expense.

What Is Not Covered

Under no circumstances does this limited warranty cover any components or parts that have been subject to the following: negligence; alteration or modification not approved by Farm King; misuse; improper storage; lack of reasonable and proper maintenance, service, or repair; normal wear; damage from failure to follow operating instructions; accident; and/or repairs that have been made with parts other than those manufactured, supplied, and or authorized by Farm King.

Authorized Dealer And Labor Costs

Repairs eligible for labor under this limited warranty must be made by Farm King or an authorized Farm King dealer. Farm King retains the exclusive discretion to determine whether it will pay labor costs for warranty repairs or replacements, and the amount of such costs that it will pay and the time in which the repairs will be made. If Farm King determines that it will pay labor costs for warranty work, it will do so by issuing a credit to the dealer's or distributor's account. Farm King will not approve or pay invoices sent for repairs that Farm King has not previously approved. Warranty service does not extend the original term of this limited warranty.

Warranty Requirements

To be covered by warranty, each new product must be registered with Farm King within thirty (30) days of delivery to original retail purchaser. If the customer decides to purchase replacement components before the warranty disposition of such components is determined, Farm King will bill the customer for such components and then credit the replacement invoice for those components later determined to be covered by this limited warranty. Any such replacement components that are determined not be covered by this limited warranty will be subject to the terms of the invoice and shall be paid for by the purchaser.

EXCLUSIVE EFFECT OF WARRANTY AND LIMITATION OF LIABILITY

TO THE EXTENT PERMITTED BY LAW, FARM KING DISCLAIMS ANY WARRANTIES, REPRESENTATIONS, OR PROMISES, EXPRESS OR IMPLIED, AS TO THE QUALITY, PERFORMANCE, OR FREEDOM FROM DEFECT OF THE COMPONENTS AND PARTS COVERED BY THIS WARRANTY AND NOT SPECIFICALLY PROVIDED FOR HEREIN.

TO THE EXTENT PERMITTED BY LAW, FARM KING DISCLAIMS ANY IMPLIED WARRANTIES OF MERCHANTABILITY AND FITNESS FOR A PARTICULAR PURPOSE ON ITS PRODUCTS COVERED HEREIN, AND DISCLAIMS ANY RELIANCE BY THE PURCHASER ON FARM KING'S SKILL OR JUDGMENT TO SELECT OR FURNISH GOODS FOR ANY PARTICULAR PURPOSE. THE PURCHASER'S ONLY AND EXCLUSIVE REMEDIES IN CONNECTION WITH THE BREACH OR PERFORMANCE OF ANY WARRANTY ON FARM KING'S PRODUCTS ARE THOSE SET FORTH HEREIN. IN NO EVENT SHALL FARM KING BE LIABLE FOR INCIDENTAL OR CONSEQUENTIAL DAMAGES (INCLUDING, BY WAY OF EXAMPLE ONLY AND NOT LIMITATION, LOSS OF CROPS, LOSS OF PROFITS OR REVENUE, OTHER COMMERCIAL LOSSES, INCONVENIENCE, OR COST OF REPLACEMENT OF RENTAL EQUIPMENT). IN NO EVENT SHALL FARM KING'S CONTRACT OR WARRANTY LIABILITY EXCEED THE PURCHASE PRICE OF THE PRODUCT. (Note that some states do not allow limitations on how long an implied warranty lasts or the exclusion or limitation of incidental or consequential damages, so the above limitations and exclusion may not apply to you.) This warranty gives you specific legal rights and you may also have other rights, which vary from state to state.

Farm King neither assumes nor authorizes any person or entity, including its selling representatives, to assume any other obligations or liability in connections with the sale of covered equipment, or to make any other warranties, representations, or promises, express or implied, as to the quality, performance, or freedom from defect of the components and parts covered herein. No one is authorized to alter, modify, or enlarge this limited warranty, or its exclusions, limitations and reservations.

Corrections of defects and improper workmanship in the manner, and for the applicable time periods, provided for herein shall constitute fulfillment of all responsibilities of Farm King to the purchaser, and Farm King shall not be liable in negligence, contract, or on any other basis with respect to the subject equipment.

This limited warranty is subject to any existing conditions of supply which may directly affect Farm King's ability to obtain materials or manufacturer replacement parts.

Buhler Industries Inc. reserves the right to make improvements in design or changes in specifications to its products at anytime, without incurring any obligation to owners of units previously sold.

www.farm-king.com

Farm King

301 Mountain Street South
Morden, Manitoba Canada R6M 1X7
Toll Free: 1-888-FK-80001
E-mail: info@buhler.com
www.farm-king.com

Equipment shown is subject to change without notice.
©2022 Buhler Trading Inc. Printed in USA TSX:BU1

bühler | a division of Buhler Industries Inc.