

Farm King

OPERATOR AND PARTS MANUAL

Round Bale Carrier

1450

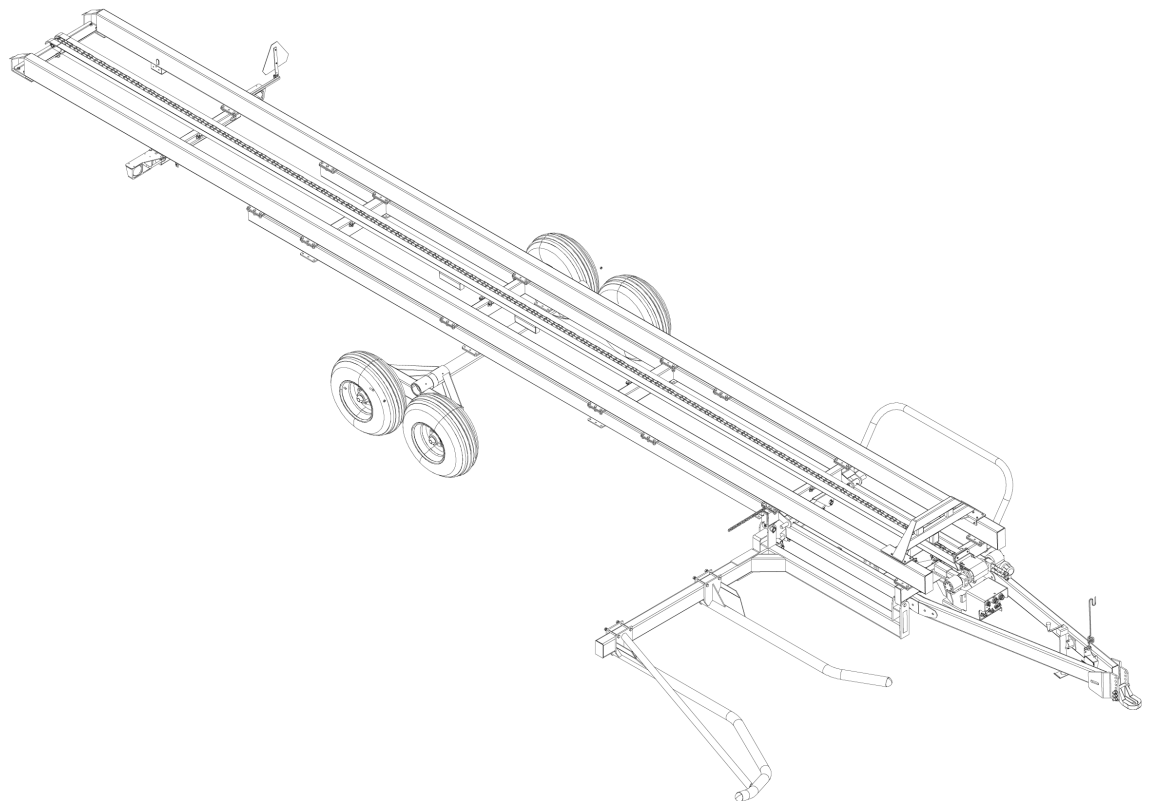

Table of Contents

General Specifications6

Introduction7

Safety.....8

- Safety8
- General Safety9
- Start-up Safety9
- Operation Safety9
- Transport Safety 10
- Service and Maintenance Safety 10
- Storage Safety 10
- Safety Signs 10
- Safety Sign Installation 10

Assembly.....13

- Tandem Axle Assembly Installation 13
- Brace Weldment Installation 13
- Tail Light Assembly 13
- Bale Retainer Weldment 14
- Fixed Loading Arm..... 14
- RPU Assembly 15
- Hydraulic Assembly 16
- Electrical Assembly 16

Start-up17

- Pre-operation Checklist..... 17

Operation18

- Attaching Bale Carrier to Tractor 18
- Optional Clevis Hitch 18
- Attaching Bale Carrier Controls to Tractor..... 18
- Carrier Control Operation..... 19
- Loading Bales..... 19
- Optional Bale Stop..... 20
- Bale Pusher Operation..... 20
- Transporting Bale Carrier 21
- Unloading 21
- Full Indicator..... 22

Maintenance23

- Fasteners23
- Hydraulic System23
- Chain23
- Wheel/Tires24
- Pivot Point Lubrication24
- Roller Chain Lubrication24
- Carrier Beam Lubrication24
- Storage25

Bolt Torque26

- Checking Bolt Torque26

Parts Drawings.....28

- Electrical Drawing (Prior to S/N BM1450R13000001 & BM1450S13000033)28
- Electrical Drawing (S/N BM1450R13000001 & BM1450S13000033 and later)29
- Control Handle Assembly Drawing and Parts List30
- Valve bank Assembly Drawing and Parts List.....31
- Manifold Service Parts Drawing and Parts List32
- Manifold Drawing33
- Hydraulic Return Line Assembly Drawing and Parts List34
- Hydraulic Pressure Line Assembly Drawing and Parts List.....35
- Carrier Tilt Cylinders Hydraulic 3/8 Line Drawing and Parts List.....36
- Carrier Tilt Cylinder Assembly Drawing and Parts List37
- Carrier Bundled Assembly Drawing28
- Carrier Bundled Assembly Parts List29
- Carrier Hydraulic Assembly Drawing - Standard Configuration30
- Carrier Hydraulic Parts List - Standard Configuration.....31
- Fixed Pick Up Cylinder Assembly Drawing and Parts List38
- Pusher Motor Assembly Drawing and Parts List.....39
- Carrier Hydraulic Assembly Drawing and Parts List40
- Carrier Hydraulic Assembly Hardware Drawing and Parts List.....41
- Carrier Bundled Assembly Drawing and Parts List42
- Tail Light Assembly Drawing and Parts List.....44
- Carrier Final Assembly Drawing and Parts List46
- Carrier Initial Assembly Drawing and Parts List48
- Complete Tandem Axle Assembly Drawing and Parts List50
- Tire Assembly Drawing and Parts List51
- Tandem Axle Assembly Drawing and Parts List52
- Hub Assembly Drawing and Parts List53
- Pusher Assembly Drawing and Parts List54
- Bale Stop Bundle Drawing and Parts List55

• Roller/Chain Guide Assembly Drawing and Parts List	56
• Fixed Pick Up Arm Hydraulic Assembly Drawing and Parts List.....	57
• Fixed Pick Up Arm with Deflector RH Side Assembly Drawing and Parts List.....	58
• RPU Squeeze Cylinder Drawing and Parts List.....	60
• RPU Lift Cylinder Drawing and Parts List.....	61
• RPU Rotate Cylinder Drawing and Parts List	62
• RPU RH Side Assembly Drawing and Parts List - Optional	64
• Hydraulic RPU Assembly Drawing and Parts List - Optional.....	66
• RPU Schematic.....	67
• Optional Adjustable Bale Stop Assembly Drawing and Parts List.....	68
• Optional Clevis Hitch Assembly Drawing and Parts List.....	69
• Standard Hitch Assembly Drawing and Parts List.....	70
Delivery Checklist	71
• Pre-delivery	71
• Customer Delivery	71
Warranty	72

Manufacturer's Statement: for technical reasons Buhler Industries Inc. reserves the right to modify machinery design and specifications provided herein without any preliminary notice. Information provided herein is of descriptive nature. Performance quality may depend on soil fertility, applied agricultural techniques, weather conditions and other factors.

General Specifications

Dimensions

- Length: 44' (13.4 m)
- Deck length: 37' (11.3 m)
- Width: 8'6" (2.6 m)
- Weight (empty): 5495 lb (2498 kg)
- Drawbar vertical load (empty): 1365 lbf (6071 n)
- GVW: 18720 lb (8491 kg)

Capacity

- Total bale payload: 13225 lb (6000 kg)
- Bales 6' (1.8 m) diameter maximum to 4' (1.2 m) diameter minimum
- Hay crop, stover, small grains, and flax straw
- Eight 4' (1.2 m) wide bales
- Seven 5' (1.52 m) wide bales

Tires

- 4-12.5 L x 15 FI - 12 ply, Load Range F, Farm Hwy Service Tire
- 6 bolt heavy-duty hubs with twine guards
- Walking beam axle design

Control Handle

- Power: 12v
- Fuse: 15 amp (surge protection provided on machine)

Hydraulics

- Two remote tractor hydraulics circuits required for operation
- Operates with either closed-center or open-center/load sensing hydraulics
- Hydraulic system selectable by rocker switch
- One Lift cylinder with restrictor
- One Tilt cylinder with restrictor
- Two 22.2" cu. (363.79 cu cm) hydraulic motors

Tractor

- Size: 60 hp (45kW) recommended
- Weight: As per ASAE specification ASAE S365.4 the tractor must weight 12480 lb (5660 kg) to adequately handle a GVW of 18720 lb (8491 kg)
- Maximum loaded towing speed 20 mph (32 km/h)

Introduction

This manual has been provided as information regarding the specifications, safe operation and maintenance of your agricultural 1450 Bale Carrier. Read and understand this manual and the tractor manual prior to operating to obtain the best use of operating your 1450 bale carrier.

Your new bale carrier is designed to retrieve, transport, and unload a wide range of round bales. Sizes that can be accommodated range from 4' (1.2 m) diameter to 6' (1.8 m) diameter in a variety of hay and stover crops as well as small grain and flax straw.

Keep this manual handy for frequent reference. All new operators or owners must review the manual before using the equipment and at least annually thereafter. Contact your Farm King Dealer if you need assistance, information, or additional copies of the manual. Visit our website at www.buhlerindustries.com for a complete list of dealers in your area.

The directions left, right, front and rear, as mentioned throughout this manual, are as seen facing in the direction of travel of the implement.

Safety

Safety Instructions

Remember, YOU are the key to safety. Good safety practices not only protect you, but also the people around you. Make these practices a working part of your safety program. Be certain that everyone operating this equipment is familiar with the recommended operating and maintenance procedures and follows all the safety precautions. Most accidents can be prevented. Do not risk injury or death by ignoring good safety practices.

The alert symbol is used throughout this manual. It indicates attention is required and identifies hazards. Follow the recommended precautions.



The safety alert symbol means...
ATTENTION! BECOME ALERT! YOUR SAFETY IS INVOLVED!



CAUTION

The caution symbol indicates a potentially hazardous situation that, if not avoided, may result in minor or moderate injury. It may also be used to alert against unsafe practices.



WARNING

The Warning Symbol indicates a potentially hazardous situation that, if not avoided, could result in death or serious injury, and includes hazards that are exposed when guards are removed. It may also be used to alert against unsafe practices.



DANGER

The Danger Symbol indicates an imminently hazardous situation that, if not avoided will result in death or serious injury. This signal word is to be limited to the most extreme situations, typically for machine components that, for functional purposes, cannot be guarded.

General Safety Instructions

- Have a first-aid kit available for use and know how to use it.
- Have a fire extinguisher available, stored in a highly visible location, and know how to use it.
- Wear appropriate protective gear. This list may include but is not limited to:
 - hard hat
 - protective shoes with slip resistant soles
 - protective glasses or goggles
 - heavy gloves
 - wet weather gear
 - hearing protection
 - respirator or filter mask
- Read and understand the Operator's Manual and all safety signs before operating, servicing, adjusting, repairing, or unplugging the equipment.
- Do not attempt any unauthorized modifications to your Farm King product as this could affect function or safety, and could affect the life of the equipment.
- Inspect and clean the working area before operating.
- Keep hands, feet, clothing, and hair away from moving parts.
- Ensure bystanders are clear of the area before operating.

Start-up Safety

- Do not let inexperienced operators or children run this equipment.
- Place all tractor and machine controls in neutral before starting.
- Ensure all shields are in place and in good condition before operating.

Operation Safety

- Do not permit riders.
- Do not wear loose fitting clothing during operation.
- Do not load bales of sizes not outlined in the specifications section.
- Never operate with frayed or damaged hoses or leaking fittings.
- If for some reason you feel the tractor tipping immediately lower lift arm.
- Do not raise lift arm to extreme heights while tractor is on an incline. Be alert for terrain changes and adjust accordingly.

Transport Safety

- Review Transport Safety instructions in tractor manual before moving.
- Check with local authorities regarding transport on public roads. Obey all applicable laws and regulations.
- Make sure the SMV (Slow Moving Vehicle) emblem and all the lights and reflectors that are required by the local highway and transport authorities are in place, are clean, and can be seen clearly by all overtaking and oncoming traffic.
- Do not overload the GVW of 18720 lb (8491 kg) and when loaded keep the speed below 20 mph (32 km/h).
- Allow for bale carrier and tractor length when turning.
- Never have the equipment in operation during transport
- Always travel at a safe speed.

Service and Maintenance Safety

- Stop engine, set brake, remove ignition key, and wait for all moving parts to stop before servicing, adjusting, repairing, or unplugging.
- Follow good shop practices including:
 - keep service area clean and dry
 - be sure electrical outlets and tools are properly grounded
 - use adequate light for the job.
- Do not attempt to clear any blockage or reach into the bale carrier with your arm or leg unless the tractor engine is stopped.
- Never work beneath a raised lift arm unless it is securely supported.
- Use only tools, jacks, and hoists of sufficient capacity for the job.
- Replace and secure all shields removed during servicing before operating.
- Use heavy leather gloves to handle sharp objects.

Storage Safety

- Store the unit in an area away from human activity.
- Do not permit children to play on or around the stored machine.
- Cover sharp or extending components to prevent injury from accidental contact.

Safety Signs

- The following illustration shows the approximate location and detail of safety signs.
- Keep all safety signs clean and legible and replace any that are damaged or missing.
- When original parts are replaced, any safety signs affixed to those parts should be replaced as well. Replacement safety signs are available from your local dealer.

Installation

- To install safety signs, ensure the installation area is clean and dry. Decide on the exact position before you remove the backing paper. Remove the smallest portion of the split backing paper and align over the specified area. Carefully press in place.
- Slowly peel back the remaining paper and smooth the remaining portion in place. Small air pockets can be pierced with a pin and smoothed out.

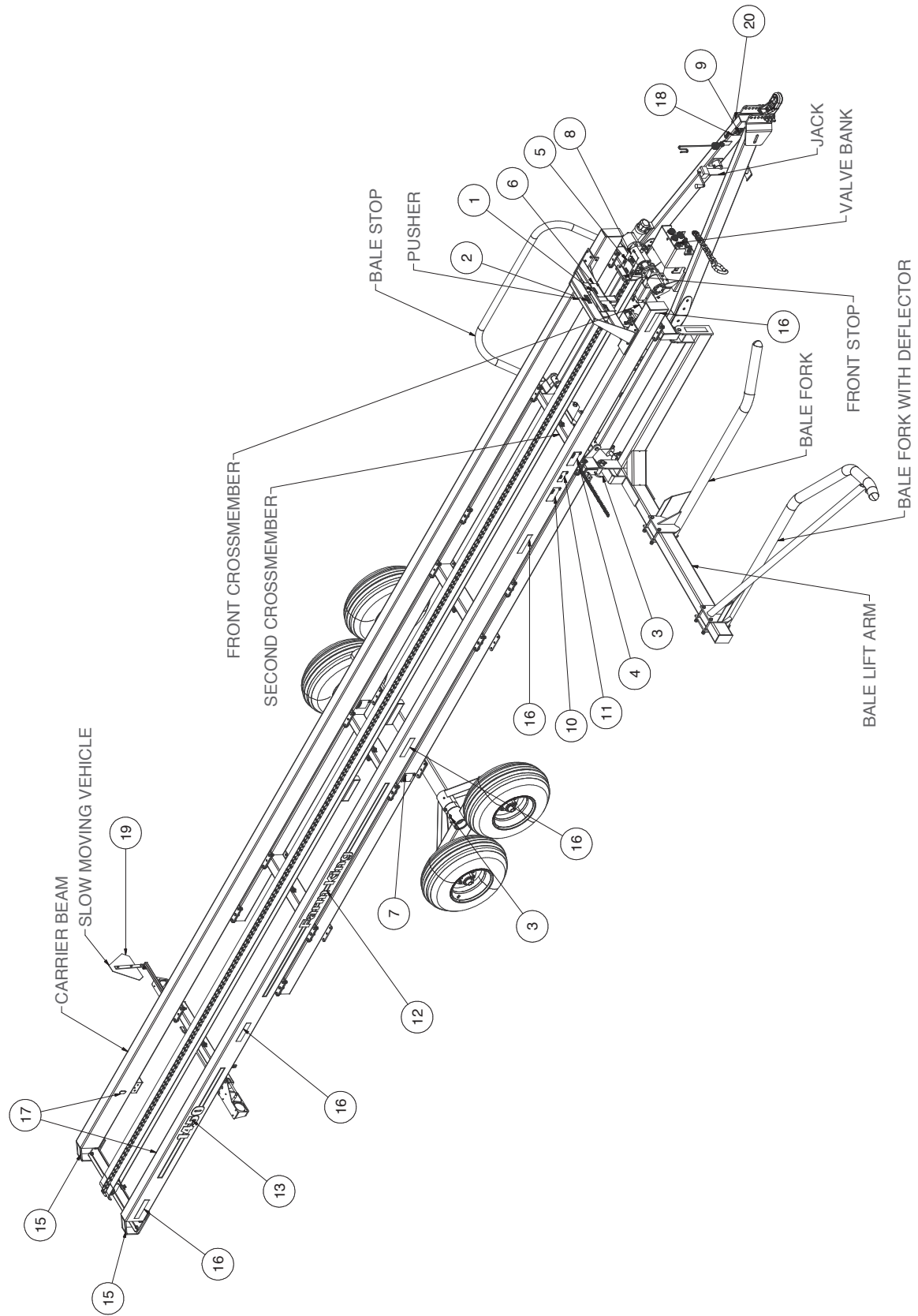

Parts List - Decals

Item	Part Number	Description	Qty
1	813624	Caution - Keep all shields in place...	1
2	813625	Important - Running pusher past amber reflector...	1
3	21867	Grease Daily	6
4	813626	Caution - Safety chain must be secured and locked...	1
5	813627	Warning - Moving part hazard...	1
6	813632	Warning - Pinching hazard...	1
7	813633	Important - Maximum recommended tire inflation...	2
8	813635	Warning - High-pressure fluid hazard	1
9	21975-02	Important - Gross vehicle weight rating...	1
10	813637	Danger - Bale lift arm can cause serious injury...	1
11	813636	Danger - Bale lift arm can cause serious pinching...	1
12	815004	Farm King	2
13	815002	1450	2
14	813952	Bale carrier snubber (prior to S/N BM1450R000001 & S/N BM1450S13000033)	1
15	967053	Red reflective	3
16	967055	Yellow reflective	11
17	813628	Amber reflective	2
18	105420	Serial number	1
19	A7017-00	SMV sign	1
20	SZ000560	Attention - Hitch Bolts Torqued	1

Assembly



CAUTION

Make sure area is clear of obstructions, well lit, and has sufficient room for safe assembly. Do not work underneath raised assembly.



CAUTION

Ensure the carrier's tires and hitch are securely blocked. Otherwise, verify the carrier is properly coupled to the drawbar on a tractor with a minimum of 12480 lb (5660 kg).

Tandem Axle Assembly Installation

(Refer to Carrier Bundled Assembly Drawing)

- Raise the main assembly to a maximum of three feet to insert the tandem axle assembly (A2400-14) on both sides. Make sure that the assembly is securely held in place. Support assembly with the appropriate rated stands for the load.
- Insert the tandem axle assembly on to the axle beam (815319).
- Insert the tandem axle locator (C8005-00) between the tandem axle assembly bushings, continue to insert the axle assembly.
- Insert nut (984077) and set screw (813547) into the locator.
- Install tires.
- Torque all fasteners to the torque specifications listed in the bolt torque section of this manual.
- Lubricate axle and hubs; refer to lubrication section for details.
- Recheck all bolt torques after first use.

Brace Weldment Installation

(Refer to Carrier Bundled Assembly Drawing)

- The carrier has six braces that need to be installed on the undercarriage of the main assembly.
- All fasteners require a flat washer and a lock nut.
- Loosely assemble and fasten all braces.
- Torque all hardware to the required torque specifications listed on the maintenance section of this manual.

Tail Light Assembly

(Refer to Carrier Bundled Assembly Drawing)

- Remove and inspect all required hardware from parts box.
- Mount lights using fasteners supplied.
- Connect the taillight wiring harnesses to their appropriate connections.
- Connect main lighting plug to tractor.
- Test by verifying correct lamps illuminate when signalling and braking.

Bale Retainer Weldment

- Remove the hardware from parts box and transfer on to bale retainer weldment. Place the weldment on the matching bolt holes in the position shown in Carrier Bundled Assembly drawing. Torque the provided hardware to the specifications listed on the bolt chart.

Fixed Loading Arm with Bale Deflector



CAUTION

Stay clear of the arm when testing a finished assembly. Ensure during assembly to keep your entire body out from underneath parts that are being attached to the main frame.

- Remove lift arm pivot pins that are installed on the carrier.
- Thoroughly lubricate all pins involved in the assembly with SAE multi purpose grease.
- Align arm to pivots with open end of arm facing forward and reinstall pins with hardware provided and torque to specifications called for in the bolt chart.
- Remove the lift cylinder pin from the arm.
- Align the lift cylinder rod and reinstall the pin.
- Adjust the outside bale fork to be positioned at the end of the lift arm. Adjust the center to center distance between the outer and inner fork per the table below. Fine tune this adjust as required for optimum performance.
 - 6 foot dia. bales - 48" center distance
 - 5 foot dia. bales - 44" center distance
 - 4 foot dia. bales - 38" center distance
- Recheck all hardware so that every bolted connection on the lift arm is torqued according to the specifications of the bolt chart.
- Approach the bale and inspect to ensure the spacing of the forks is accurate.
- For first operation, cycle the lift arm slowly with a bale and inspect just before lifting bale from ground.
- Finish the cycle and observe how the bale transits from the forks to the carrier beam. If transition is smooth with minimum bale binding, assembly is completed. If not, adjust the forks to a different location and try until loading is smooth.

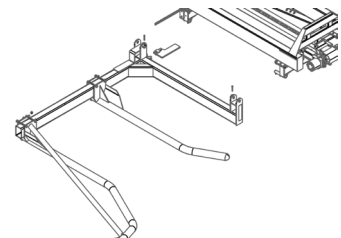

RPU Assembly

- Remove lift cylinder and install pilot check assembly.
- Reinstall cylinder at base end only.
- Lubricate all pins involved in RPU attachment with a SAE multi purpose grease.
- Align arm to pivots with open end of arm facing away from the carrier and reinstall pins with hardware provided and torque to specifications called for in the bolt chart.
- Remove the lift cylinder pin from the RPU arm.
- Align the lift cylinder rod and reinstall the pin.
- Adjust the outside bale fork to be positioned at the end of the lift arm and the inner bale fork 6" (15 cm) to 8" (20 cm) bigger than the size of bale that is being loaded.
- Install the hydraulics according to the hydraulic assembly. Hose clamp is available to attach hoses to bottom of chain rail.
- Recheck all hardware so that every bolted and hydraulic connection on the lift arm is torqued according to the specifications of the torque charts.
- The RPU cycle should begin with a squeeze action, then lift and rotate. After rotation is complete the lift continues until the bale is above the carrier beams.
- Release lift arm up when bale is above the carrier beam. Depress lift arm down to release the bale and return to ground level ready for the next bale.
- For the first operation, cycle the lift arm slowly with the bale and observe the RPU operation.
- Approach the bale slowly; once the bale is captured in the forks press the lift switch. The bale is squeezed until the pressure in the sequence valve, which is preset at 1800 psi (12400 kpa), has been achieved.
- If bale is not held in between the forks increase the sequence valve pressure by turning the setscrew clockwise. Refer to the RPU rotate cylinder drawing for adjustment location of the setscrew. Verify that the fork spacing is accurate and refer to the drawing on this page for fork adjustments.
- The lift and rotate sequence won't begin until the clamp pressure is met within the sequence valve.
- When the clamp pressure is met, the lifting action should start before the rotating action to minimize bale damage from the moving ground.
- To increase lift prior to rotate turn the restrictor knob clockwise. Refer to the RPU rotate cylinder drawing for more information.
- Continue to raise the bale until it is positioned above the carrier beam.
- To release the bale, depress lift arm down.
- Finish the cycle and observe how the bale transits from the forks to the carrier beam. If transition is smooth with minimum bale binding, assembly is completed. If not, adjust the forks to a different location and try until loading is smooth.

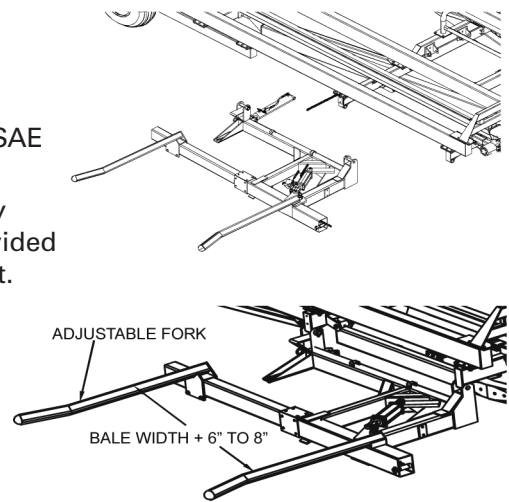

Hydraulic Assembly

NOTE: Seal kits and service parts are only listed in the parts lists and are not indicated on the illustrations.

Electrical Assembly



WARNING

Read and understand the safety messages listed in the bale carrier operator manual. Shut off all power to unit before inspecting, servicing, adjusting or repairing the bale carrier.

Prior to S/N BM1450R13000001 & S/N BM1450S13000033



WARNING

For proper operation of the snubber, power must be supplied to the RED power wire from the control handle. Ensure that there is a 15-amp fuse in place to protect this circuit. Verify prior to installing snubber. Incorrect wiring will result in electrical failure.

NOTE: The snubber unit is designed to protect the momentary control switches. The snubber minimizes coil voltage discharge during the de-energizing of the valve solenoid coils. There are no serviceable parts within the unit. Ensure that all electrical connections are clean and dry. Test the bale carrier and view to see if the hydraulic system is operating correctly. If any wires are damaged or cut, the schematic on the next page will assist in repair and maintenance. All wire is 18 gage.

Start-up

Pre-operation Checklist

To ensure safe and proper operation of the bale carrier, inspect the following items prior to operation and daily thereafter. Refer to operation, lubrication and maintenance sections for detailed instructions.

Prior to first use verify that the bale carrier has been properly assembled and that the operator understands the safety, operating, and maintenance requirements.

Check for missing fasteners and replace if necessary. Refer to maintenance section for details.

Check and maintain proper tire pressure of 90 psi (620 kpa).

Check for loose wheel bolts. Bolts must be torqued to 110 ft lb (149 Nm).

Clean bale carrier of any foreign material that may have accumulated from previous run.

Lubricate all points requiring daily lubrication.

Check chain tension and adjust if necessary with front sprocket adjusting bolt (approximately 6" (15 cm) of upward slack). This is verified by raising the chain by hand.

Ensure top surface of bale carrier beams are properly coated with a graphite coating to reduce bale friction while pushing bales back.

Ensure that the tractor used to pull the bale carrier is in working order according to the tractor manual.

Verify the bale carrier is properly coupled to the tractor with the safety chain.

Inspect all safety reflective decals, slow moving vehicle decals and lights where applicable.

Inspect the hydraulic system on the bale carrier and your tractor for leaks or any other damage.

Ensure the control handle actions reflect the movements of the bale carrier.

Inspect all electrical connections to ensure proper function of the machine.

Ensure transport safety chain is disengaged from bale lift arm and stored on chain lug located on second cross member. Failure to do so may cause damage to lift arm.



CAUTION

Make sure the tractor has a 60 hp (45 kw) or greater rating and a mass of 12480 lb (5660 kg). Make sure the drawbar is capable of supporting the bale carrier empty or loaded.



WARNING

The tractor must be equipped with an approved Roll Over Protection Structure (ROPS) and seat belts to help prevent personal injury or death caused by tractor roll over.

Operation Instructions



CAUTION

Prior to operation ensure the operator has read and understands the safety requirements of the bale carrier. Ensure the pre-operation checks have been completed prior to operation.

Attaching Bale Carrier to Tractor



CAUTION

Shut off tractor, engage parking brake and remove key before working around bale carrier. Refer to tractor manual for tractor parking procedures.



CAUTION

Use only the drawbar to couple the bale carrier to the tractor. Ensure drawbar is capable of handling the bale carrier load. The tractor must have a minimum mass of 12480 lb (5660 kg) and recommended 60 hp (45 kw).

- Using the tongue jack, raise tongue to align with hitch pin, adjust clevis position as necessary to level the carrier beams.
- Position tractor and secure with locking type drawbar pin (not supplied). Use an approved hitch pin with a mechanical retainer.
- Route safety chain around the hitch clevis, around drawbar support and back hook. Refer to tractor manual for further drawbar instructions.
- Do not use intermediate support on drawbar as attaching point.
- Store safety chain off the ground when not in use. If safety chain is damaged in any way, contact your dealer for a replacement.

Optional Clevis Hitch (SZ000513)

- For tractors not equipped with a clevis drawbar, a clevis hitch for the bale carrier is available. Use an approved hitch pin with a retainer.

Attaching Bale Carrier Controls to Tractor

- Bale lift and push functions are controlled by the bale carrier valve. Two hoses complete with black hydraulic tip covers supply pressure and tank. The retraction hose is designated with a check valve and ensures proper flow through the valve. Connect the return hose to the retract circuit and the extend hose to opposite extend port.
- The tilt function is controlled by the tractor's remote valve. Two hoses complete with red hydraulic tip covers supply extension and retraction.
- Connect control handle harness to the machine harness. Connection is made at the snubber unit by matching the appropriate socket and plug.
- The power required to operate the Bale Carrier is supplied by the tractors 12-volt electrical system. Tractors without a female power plug as standard equipment will require Tractor Harness Kit A4000-00. When using kit A4000-00, connect the red wire to the tractor positive

and green to the tractor ground. The 15-amp fuse must be used on the positive wire as supplied.

- For tractors with the operator's station further from the hitch point, 4WD for example, a 10' extension harness, 816017, is available.
- Verify bale carrier operation matches bale carrier control handle decal.
- Select your hydraulic system using the switch located behind the hydraulic manifold.
- For tractors with open-center power beyond or load sense hydraulic systems, set switch to open.
- For tractors with closed-center hydraulic systems, set switch to close

Carrier Control Operation

- To start bale carrier operation, engage the remote hydraulic valve in the extension position. Lock valve in detent. Valve to remain constantly on during operation.
- The control handle is fitted with one rocker switch and two momentary contact rocker switches. They function as follows:
 - Pusher Speed: Select high (rabbit) to operate pusher motors in series at high speed or low (turtle) to operate in parallel at low speed. Torque is increased at low speed and pushes bales with more force.
 - Pusher: Depress and hold pusher forward to move forward. Depress and hold pusher back to move pusher back.
 - Lift Arm: Depress and hold lift arm up to raise lift arm. Depress and hold lift arm down to lower lift arm.
- To operate raise / lower tilt function engage the remote hydraulic valve in the extension position to raise the tilt deck and engage the retract position to lower the deck.

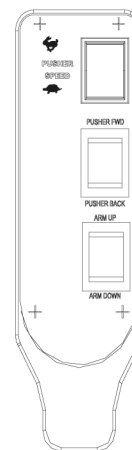

Loading Bales

	<p>WARNING</p>	<p>Make sure area is clear before lowering bale lift-arm. Failure to do so could result in injury or death.</p>
---	-----------------------	---

- Align the tractor and bale carrier as indicated in the pictorial for pick up method used. Slowly approach the bale at 5 mph (8 km/h) while loading. When bale is properly captured, begin to lift bale.
- The bale carrier is designed to load bales with one of three options. Refer to the appropriate section for your option loading instructions.

NOTE: Before loading bale the pusher must be at the front of the carrier deck.

- The Fixed Pickup Arm with Deflector allows the bales to be picked up from either "End On" or "Side On." To pickup bales that are placed "End On," drive so the inner arm of

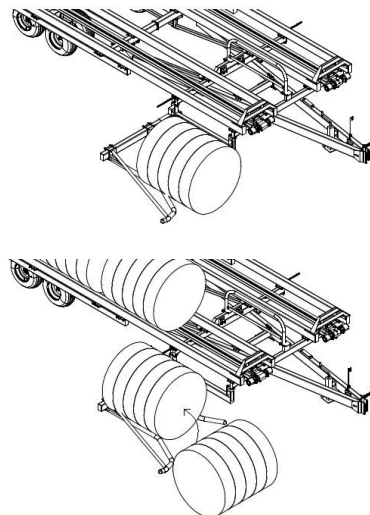

the loading fork is against the inner edge of the bale. The bale will then be loaded onto the carrier in the same direction as it was picked up.

- The deflector rotates the bale 90 before it is lifted up onto the carrier. Forward travel is used to rotate the bale. Approach the bale so that the outer end of the bale rides up on the bale deflector as the loading arm moves under the bale.
- The bale is loaded onto the carrier deck by depressing and holding RH LIFT ARM UP until the bale rolls off the pickup arm and onto the carrier beams.

NOTE: The bale should be contacted about 12" (30 cm) from its outer end when using the bale deflector. Contacting the bale further to the inside may result in damage to the deflector, bale lift arm or bale.

- The rotating pick up arm (RPU) loads bales "side on". The lift arm starts in the lowered position. Drive forward until the forks are positioned around the ends of the bale with the inside stationary fork as close as possible to the bale. Depress and hold lift arm up. The bale is then squeezed on end until the pressure matches the sequence valve setting that rotates and raises the bale.

When the bale is lifted above, the bale is released by depressing lift arm down. This releases the bale and returns the RPU to the ready state for the next bale. Refer to the assembly instructions for adjusting RPU's settings.

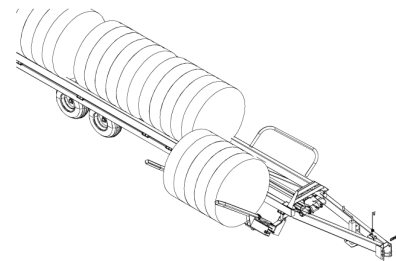
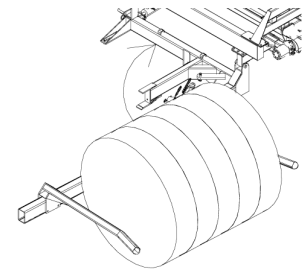

Optional Bale Stop (815692)

- When loading narrower bales (4'), an adjustable bale stop is available. Using this stop permits loading bales closer to the front of the bale carrier so a full complement of 10 bales can be loaded. This stop is bolted to the lift arm with supplied U-Bolts and is adjusted to the position desired.

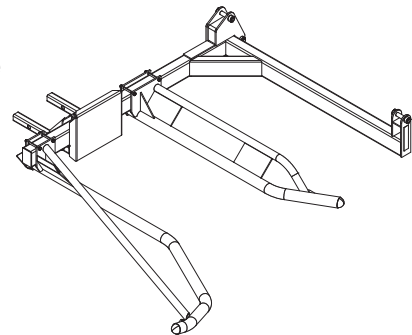

Bale Pusher Operation

NOTE: Lower loading arm before operating the pusher.



CAUTION

To avoid misbalanced loads the operator is only required to push back one bale length to prepare for the next bale.

- Depress and hold pusher back and move bales far enough to the rear to provide room to load the next bale.
- Return pusher all the way to the front by depressing and holding pusher forward.
- Hi speed / low torque mode is recommended for normal use.
- Low speed / high torque mode is for heavier payloads or situations where bales are wet or resist sliding.

Transporting Bale Carrier



WARNING

Do not tow over 20 mph (32 km/h) when loaded. Turn on flashing lights when transporting on public roadways. Obey local regulations regarding road transport. Raise bale lift arm and use the safety chain when transporting. Ensure the lift arm chain latch is used to prevent the safety chain from dislodging or loosening.

- Do not transport if end bale is overhanging beams. Beam should extend beyond last bale for a minimum of 2' (61 cm).
- Raise lift arm prior to transport. Always engage lift arm lock chains when transporting on public roadways or when not in field. Lock chain in position with latch provided.
- Monitor the condition and position of bales that are being transported
- Slow speed when transporting over bumps or rough terrain.

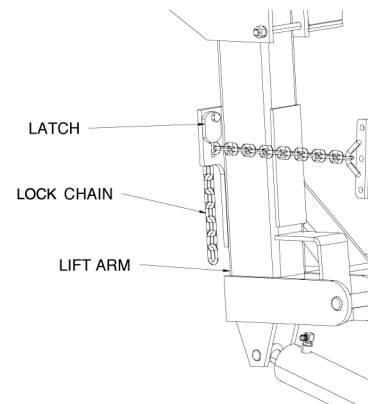

Unloading

NOTE: Do not run pusher all the way to the end, the resulting shock load may cause damage to chain and drive.



DANGER

Make sure area is clear before unloading. Failure to do so could result in serious injury or death.

- Extend tilt cylinder to raise carrier beam by engaging the tractor's extension hydraulics.
- Depress and hold the pusher back switch to push the bales off the carrier beam.
- Once the rear bale has been pushed off the carrier, slowly drive forward while pushing the bales back (unloading) to keep all bale ends in contact.
- When amber reflector on inside of the carrier beam becomes visible stop the pusher. The reflector is approximately 26" (66cm) from the end of the beam.

Release pusher back and slowly drive forward to unload the last bale. Retract the tilt cylinder to lower the beam and begin the next loading cycle.

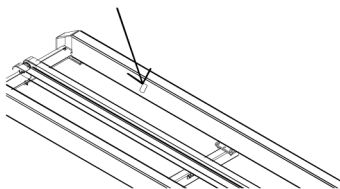

Full Indicator

The full indicator is a factory installed feature. The mechanism has dual-function as follows:

- When the bale carrier reaches its capacity, the rear indicator pivots backward pulling the cable so that the front indicator plate moves upright to signal not to load any more bales.
- At the end of the unloading process, front indicator comes down (after pushing off the last bale) warning the operator to release pusher back button, then move forward, lower beam and bring the pusher home.

Maintenance



CAUTION

Place all controls in neutral, stop engine, set parking brake and remove ignition key before inspecting, servicing, adjusting or repairing the bale carrier.



CAUTION

Ensure the bale carrier tires and hitch are securely blocked. Otherwise, verify the bale carrier is properly coupled to the drawbar on a tractor with a minimum mass of 12480 lb (5660 kg).

NOTE: Service intervals should be increased when operating in extreme or difficult conditions.

Fasteners

- Inspect all bolt torques after first use and 50 hours thereafter.
- Periodically inspect for broken or missing fasteners. Replace with fasteners of similar size and equivalent grade.

Hydraulic System

- Before applying pressure to the system, be sure all connections are tight and the lines, pipes, and hoses are not damaged.
- Wear proper hand and eye protection when searching for leaks. Use a piece of wood or cardboard instead of hand to check for leaks.
- Maintain all components in good working order.
- If injured by escaping fluid, see a doctor at once. Serious infection or toxic reaction can develop if proper medical treatment is not administered immediately.
- Regularly check the fluid level in the tractor reservoir and follow the maintenance procedures in the tractor Operator's Manual.
- Regularly inspect cylinders, hoses and fittings for leaks, crimps and abrasions or other signs of wear and tear or impending failure.
- Ensure hoses do not bind or stretch during operation. Always keep hoses tied or supported to prevent rubbing against sharp areas or being pinched. We suggest using tie wraps to support hoses.
- Replacement hoses must have a working pressure of 3000 psi (20685 kpa) or higher.

Chain

- Check for proper chain tension and sprocket alignment after first use and every 50 hours thereafter.
- Turn the front sprocket-adjusting bolt clockwise until there is approximately 6" (15 cm) of upward slack in the chain at the center of the track. Clockwise increases tension and counter clockwise reduces tension.
- Proper chain tension may be verified by raising the chain by hand.
- See lubrication section for further maintenance instructions.

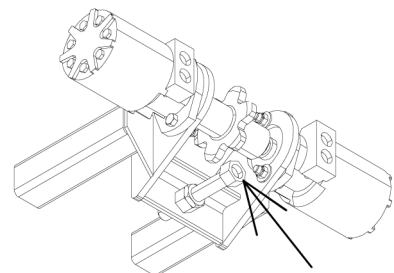

Wheel/Tires

- Inspect hub bolts after first use and 50 hrs thereafter. Hub bolts must be torqued to 110 ft-lb (149 Nm).
- Thread-locking compound such as Loctite 242 is recommended for the hub bolts.
- Ensure that dust caps are firmly in place.
- Check tires pressure regularly: 90 psi (620 kpa).
- The wheel bearings should be inspected and re-packed annually with SAE multi purpose type grease. Grease every 500hrs if hub is supplied with grease fitting.
- Air valve should face away from the hub.

Pivot Point Lubrication

- Lubricate bale carrier bushings and pivots every eight hours of average operation with high grade grease at all fitting locations. Select grease based on the expected outside temperature range. Lithium, Molybdenum and synthetic greases are preferred. Use the tractor hour meter as a guide. Increase lubrication intervals for extreme use or adverse conditions. Each pivot should be lubricated until grease is visible at pin. The fixed arm carrier has 12 lubrication points and the RPU carrier has 13 points. Refer to the illustrations below for locations.

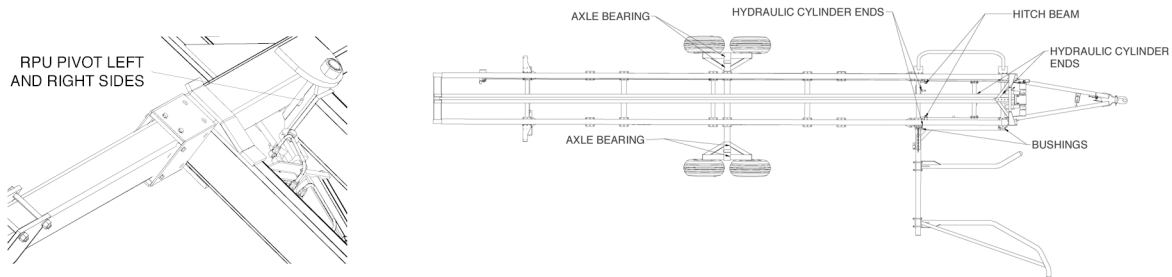

Roller Chain Lubrication

- Manually brush SAE lubricant while chain is stationary.
- Lubricate the chain every time bolt torque maintenance is performed.

Carrier Beam Lubrication

- Apply a graphite coating such as slip plate to the carrier beams as required to ensure a smooth push back operation.
- Follow application instructions as provided by the coating manufacturer.
- At the end of the season apply a coating to prevent rust on the carrier beams.

Storage

Start of season

- Clean and inspect the bale carrier when taking it out of storage. Ensuring that the bale carrier is in optimum condition at the start of the season reduces the chances of a costly breakdown during the season.
- Clean and inspect chains and chain rollers for excessive wear or stiffness. Check for proper adjustment and alignment.
- Lubricate entire bale carrier. Ensure that all grease fittings are in place and taking grease properly.
- Operate the bale carrier for a short time. Check that all moving parts are operating freely. Check for hydraulic leaks.
- Inspect and repack wheel bearings with SAE multi purpose type grease.
- Replace and secure safety shields. Review safety regulations.
- Check all bolts for tightness. Replace lost or worn bolts.
- Check that tires are properly inflated.
- Review the Operator's Manual.

During the season

- At the end of each day of operation park the bale carrier in a clean, dry, sheltered area.
- Lubricate areas requiring daily lubrication.
- Remove any build up of hay or straw.





End of season

- Check for worn or damaged parts and replace if necessary. To avoid costly delays contact your dealer for replacement parts before the start of the next season.
- Store the bale carrier in a clean, dry, sheltered area.
- Replace all missing or broken bolts with bolts of similar size and grade.
- Clean the baler carrier thoroughly. Dirt draws moisture that rusts metal.
- Repaint chipped or worn areas. Paint is available from your dealer.
- Clean chains and brush with SAE light machine oil (or equivalent) to prevent rust.
- Repaint the top of the carrier beams with graphite paint such as slip plate to prevent rust.

Bolt Torque

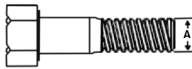
Checking Bolt Torque

The tables shown below give correct torque values for various bolts and hex bolts. Tighten all bolts to the torques specified in chart unless otherwise noted. Check tightness of bolts periodically, using bolt torque chart as a guide. Replace hardware with the same strength bolt.

Bolt Torque* (plated bolts)						
						
Bolt Diameter (inches)	Grade 2 Bolts SAE 2		Grade 5 Bolts SAE 5		Grade 8 Bolts SAE 8	
"A"	(lb-ft)	(N.m)	(lb-ft)	(N.m)	(lb-ft)	(N.m)
0.25 (1/4)	3	4	6	8	9	12
0.313 (5/16)	7	9	13	18	18	24
0.375 (3/8)	12	16	23	31	35	47
0.438 (7/16)	17	23	35	47	50	68
0.5 (1/2)	31	42	55	75	80	108
0.563 (9/16)	42	57	80	108	110	149
0.625 (5/8)	78	106	110	149	160	217
.75 (3/4)	121	164	200	271	280	380
0.875 (7/8)	160	217	320	434	450	610
1	240	325	480	651	680	922

Torque figures indicated above are valid for non-greased or non-oiled threads and heads unless otherwise specified. Therefore, do not grease or oil bolts or hex bolts unless otherwise specified in this manual. When using locking elements, increase torque values by 5%.

*Torque value for bolts and hex bolts are identified by their head markings.

Hydraulic Fitting Torque					
Dash Size	Thread Size	Jam Nut or Straight		SAE 37° (JIC)	
		ORB Fitting Torque		Swivel Nut Torque	
		(lb-ft)	(N.m)	(lb-ft)	(N.m)
-04	7/16-20	14-16	20-22	10-11	13-15
-05	1/2-20	18-20	24-27	13-15	18-20
-06	9/16-18	24-26	33-35	17-19	23-26
-08	3/4-16	50-60	68-78	34-38	47-52
-10	7/8-14	72-80	98-110	50-56	69-76
-12	1-1/16-12	125-135	170-183	70-78	96-106
-14	1-3/16-12	160-180	215-245	80-90	110-122
-16	1-5/16-12	200-220	270-300	94-104	127-141
-20	1-5/8-12	210-280	285-380	124-138	169-188
-24	1-7/8-12	270-360	370-490	156-173	212-235

When Ordering Parts

Always give your dealer the Model, Color and Serial Number of your machine to assist him in ordering and obtaining the correct parts. Use the exploded view and tabular listing of the area of interest to exactly identify the required part.

Electrical Drawing (Prior to S/N BM1450R13000001 & BM1450S13000033)

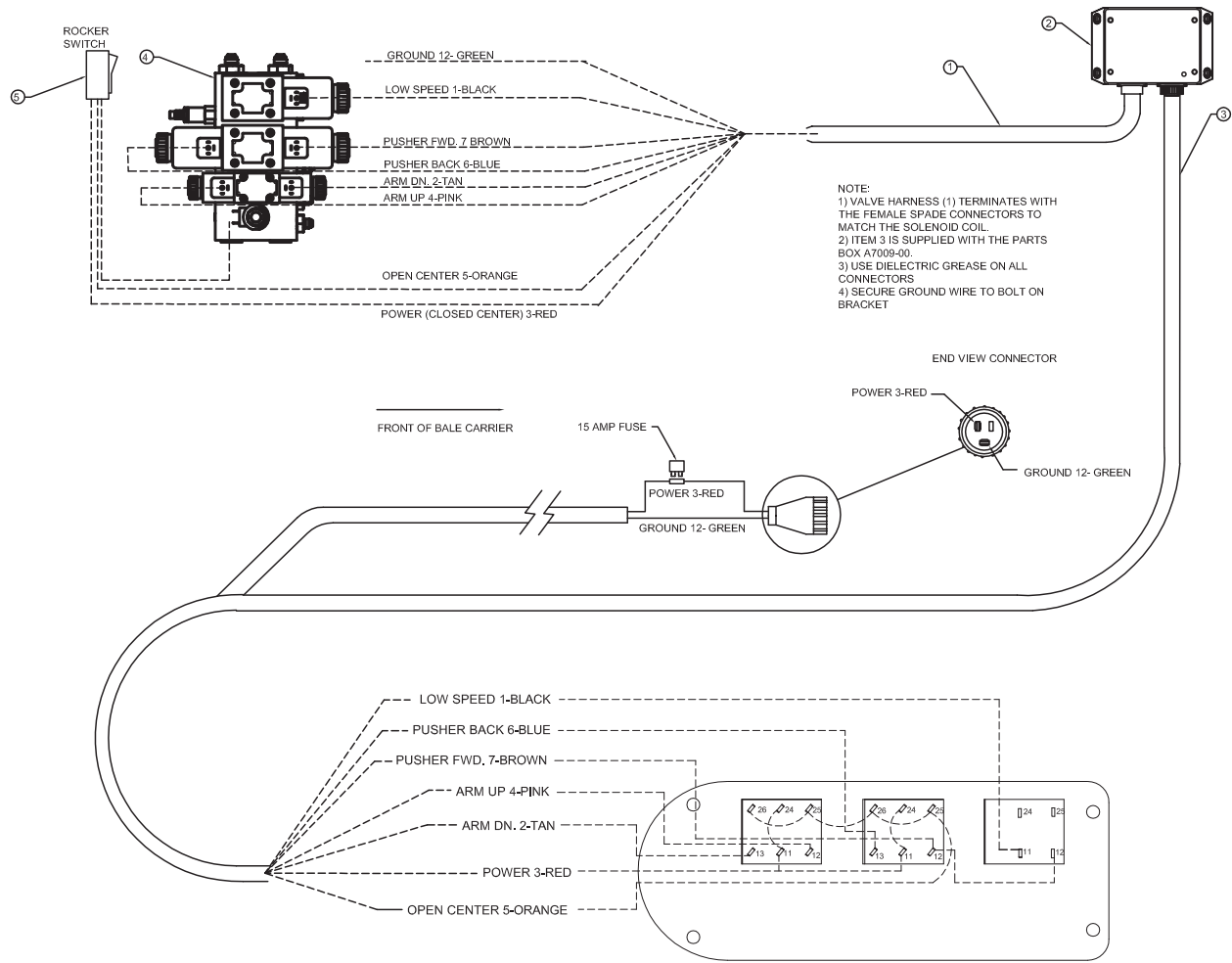

Item	Part Number	Description	Qty
1	83000057	Machine Harness 1450 Bale Carrier	1
2	813949	Snubber Unit	1
3	I20024	Control Handle Harness Assembly 1450	1
4	83000055	Valve Bank Assembly 1450 Bale Carrier	1
5	SZ000759	Open/Close Switch	1

Optional			
	A4000-00	Tractor Power Ext. Kit	1
	816017	10' Extension Harness	1

Electrical Drawing (S/N BM1450R13000001 & BM1450S13000033 and later)

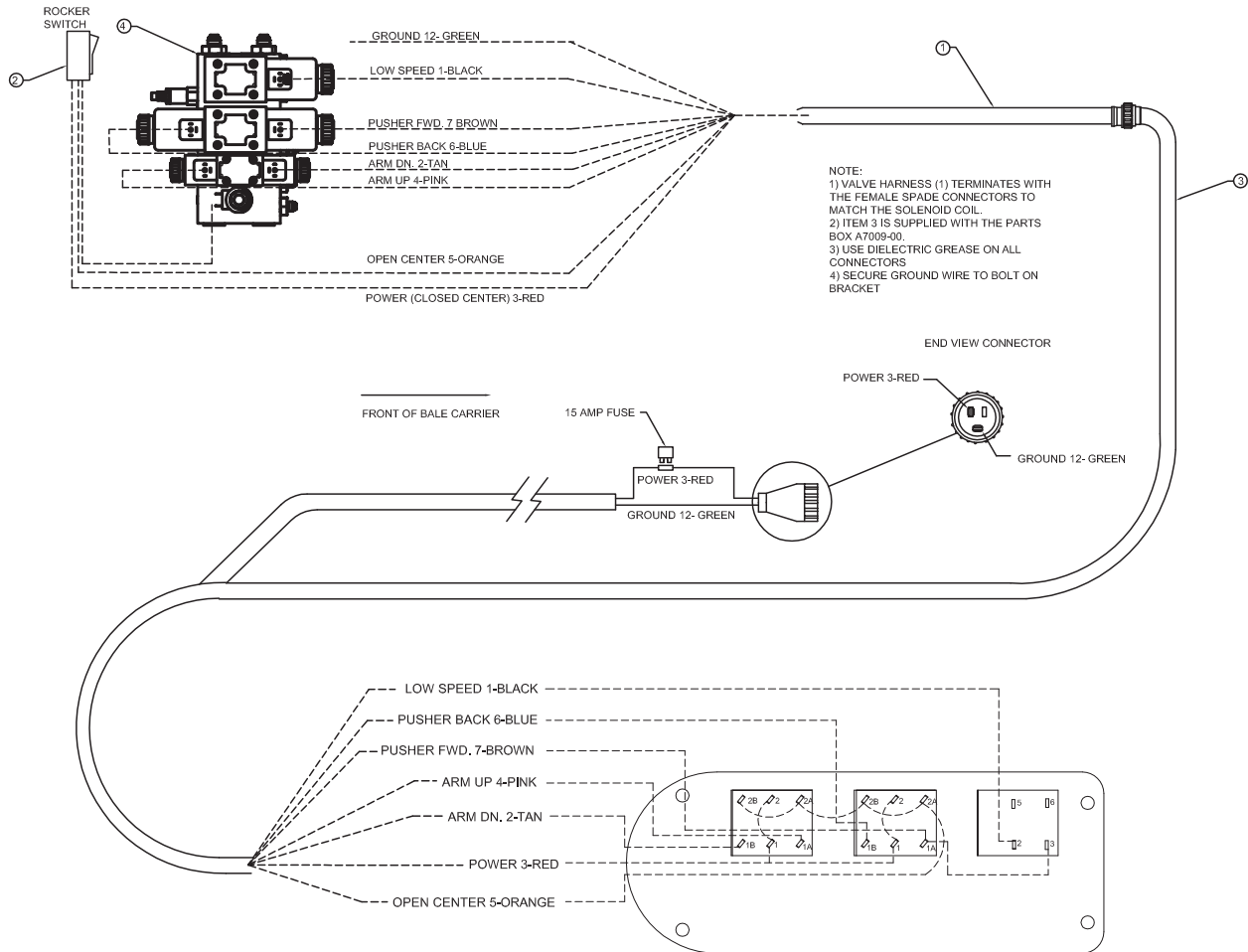

Item	Part Number	Description	Qty
1	SZ000567	1450/2400 Valve Wiring Harness	1
2	SZ000759	Open/Closed Switch	1
3	I20024	Control Handle Harness Assembly 1450/2400	1
4	83000055	Valve Bank Assembly 1450 Bale Carrier	1

Optional			
	A4000-00	Tractor Power Ext. Kit	1
	816017	10' Extension Harness	1

Electrical Drawing (2018 models and later)

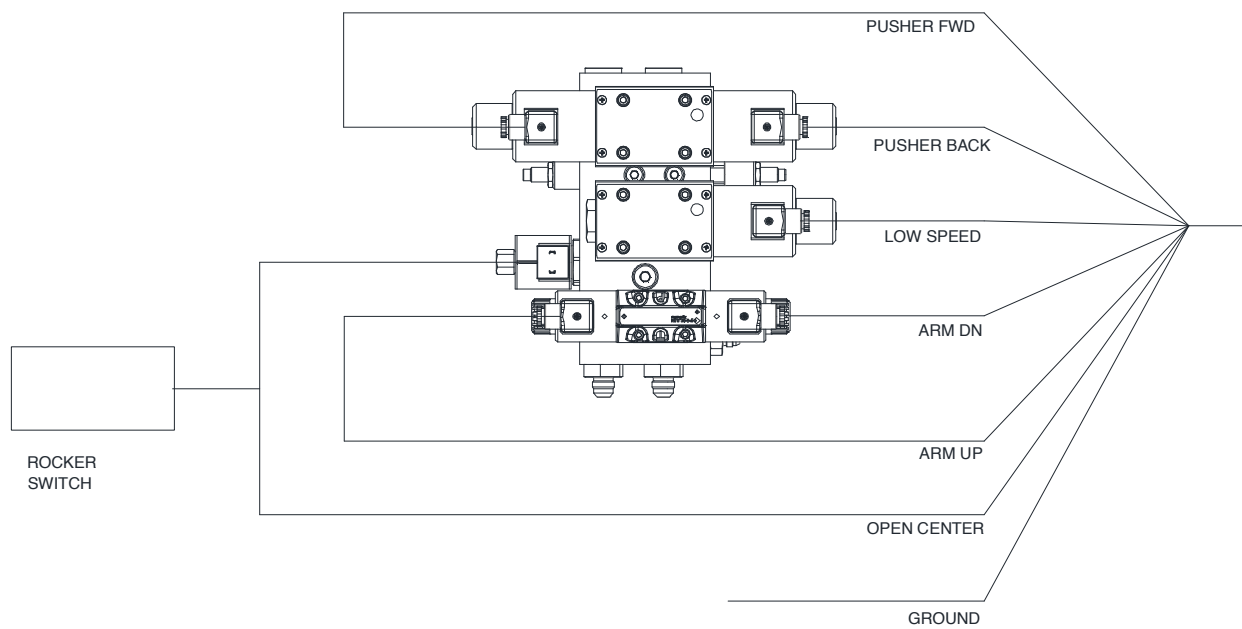

Control Handle Assembly Drawing - I20024

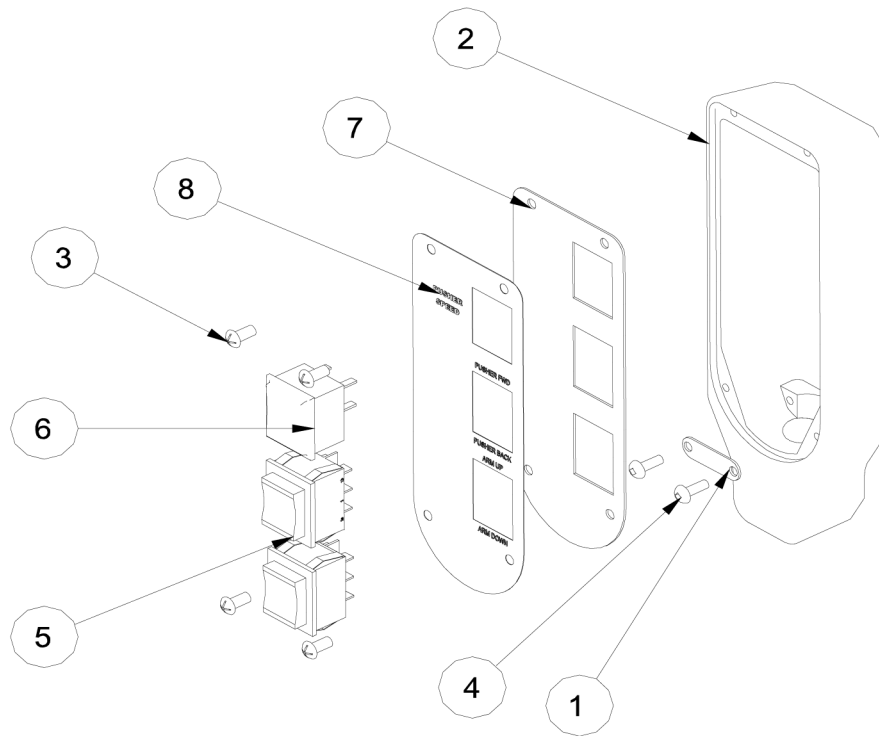

Item	Part Number	Description	Qty
1	22105	Control Handle	1
2	813540	Screw MACH 8-32 x 0.50 RD HD	6
3	814448	Switch Cover Decal - 1450	1
4	I100016	Switch Cover Plate - 1450	1
5	INE22105-01	Wire Clamp Plate	1
6	815382	Rocker Switch On-Off	1
7	815383	Rocker Switch (On)-Off-(On)	2
8	814448	Decal Buhler 1450	1

Hydraulic Return Line Assembly Drawing - A7010-00

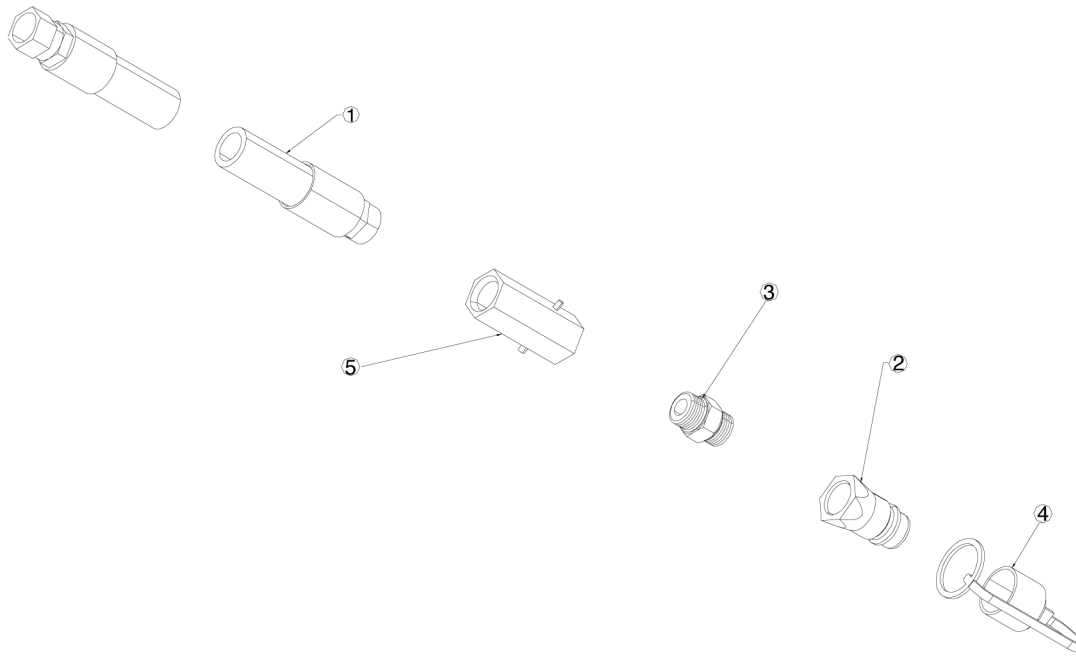

Item	Part Number	Description	Qty
1	29170	Hose 1/2 x 130 3/4 Morb x 3/4	1
2	812841	Male Tip 0.5 Body 0.75 Orb	1
3	813119	Adaptor Str 3/4 Morb x 3/4 Morb	1
4	813305	Dust Cap 0.5 Black	1
5	813666	Valve Check 3/4 Orb Line	1

Hydraulic Pressure Line Assembly Drawing - A7011-00

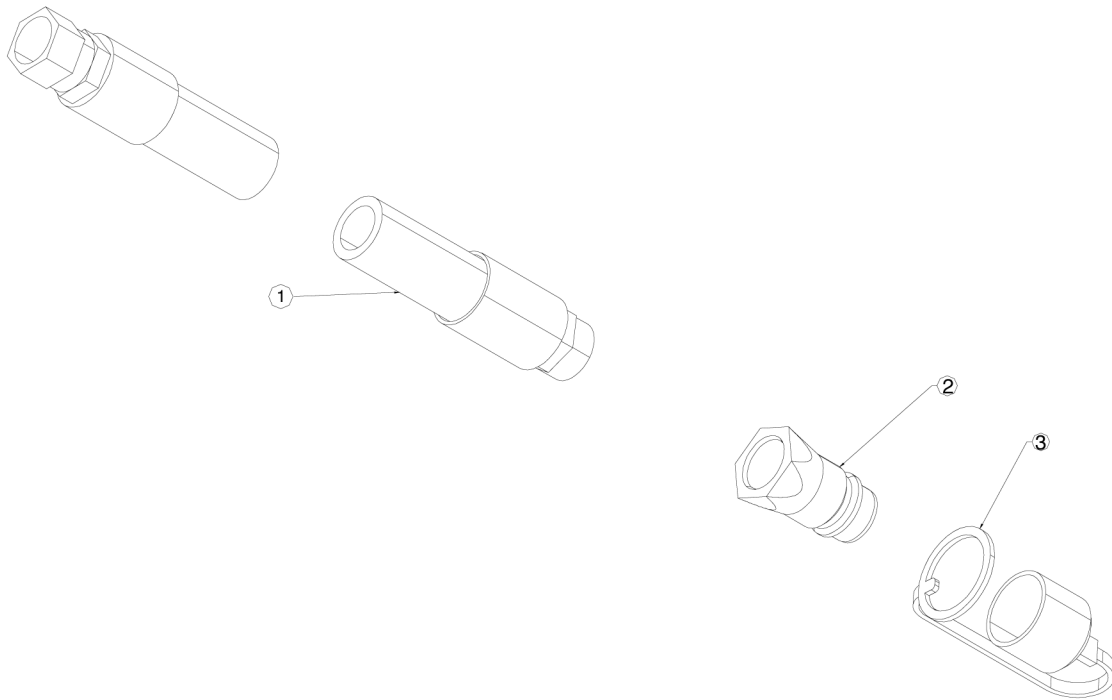

Item	Part Number	Description	Qty
1	29170	Hose 1/2 x 130 3/4 Morb x 3/4	1
2	812841	Male Tip 0.5 Body 0.75 Orb	1
3	813305	Dust Cap 0.5 Black	1

Carrier Tilt Cylinders Hydraulic 3/8 Line Drawing - A8013-00

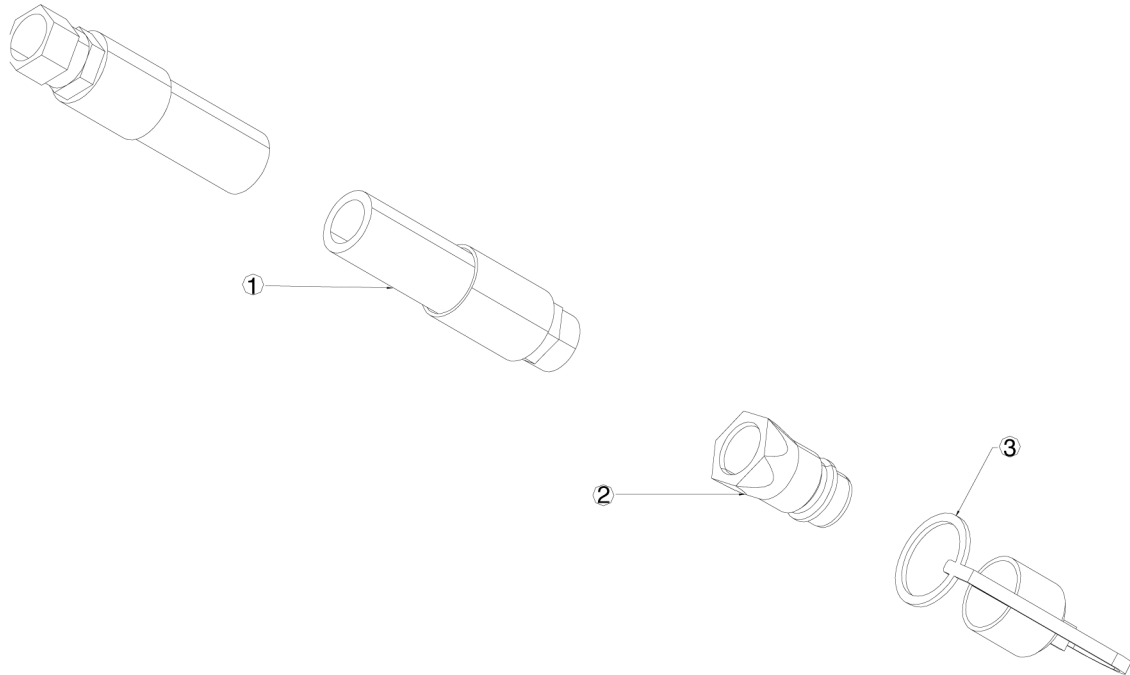

Item	Part Number	Description	Qty
1	29174	Hose 3/8 x 168 9/16 Swfjic x 3/4 RB	1
2	812841	Male Tip 0.5 Body 0.75 Orb	1
3	813303	Dust Cap 0.5 Red	1

Carrier Tilt Cylinder Assembly Drawing - A8012-00

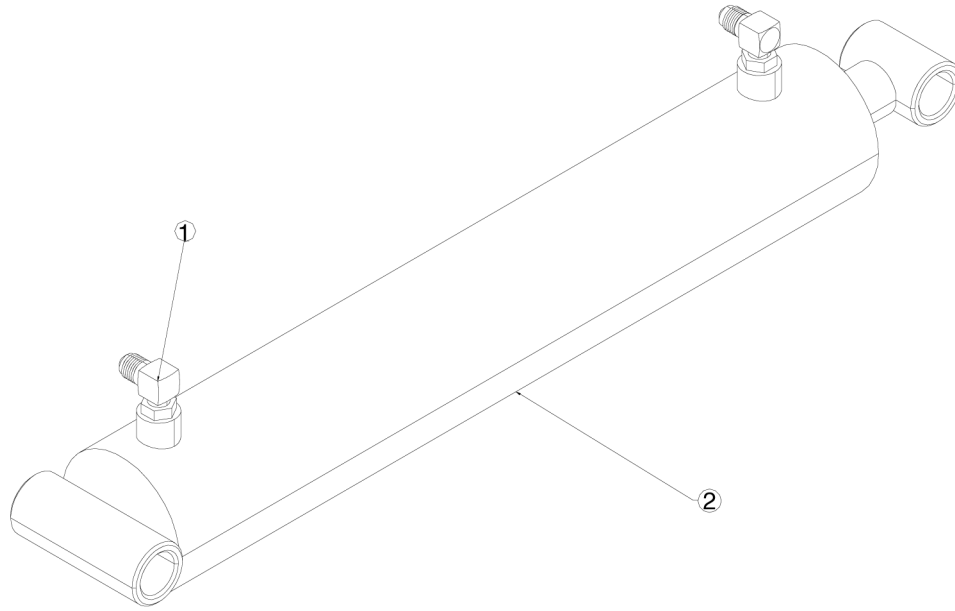

Item	Part Number	Description	Qty
1	29170	Hose 1/2 x 130 3/4 Morb x 3/4	2
2	812841	Male Tip 0.5 Body 0.75 Orb	1

24895 Cylinder 3.0 Diameter Service Parts

	812655	Locknut 0.875 Nf	1
	X2353	Seal Kit for Item 248945	1
	24899	Tube Weldment 3.0 Dia	1
	115288	Shaft Weldment 1.25 x 16.75 Lg	1
	24897	Headplate 3.0 x 1.250 Rod	1

Fixed Pick Up Cylinder Assembly Drawing - A7013-00

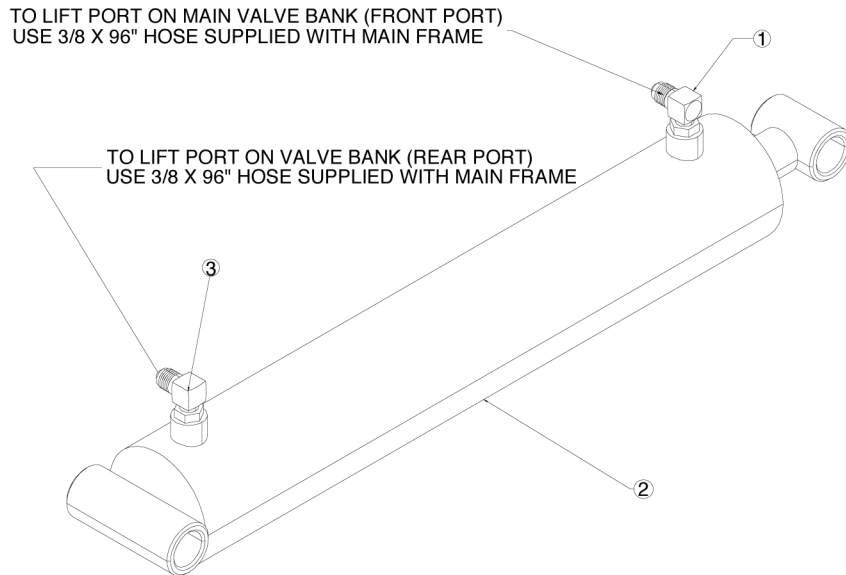

Item	Part Number	Description	Qty
1	813640	Elbow 90 9/16 Morb Adj 9/16 Mjic	1
2	22510	Cylinder 3.0 Dia x 16 Inland	1
3	E2872-00	Elbow Restrictor Male 90°	1

22510 Cylinder 3.0 Diameter Service Parts

	813407	Locknut 1.00 Nf	1
	X2504	Seal Kit for Item 22510	1
	24957	Tube Weldment 3.0 Dia	1
	115519	Shaft Weldment 1.50 x 22.63	1
	24598	Head Plate 3.0 x 1.50	1

Pusher Motor Assembly Drawing - A8011-00

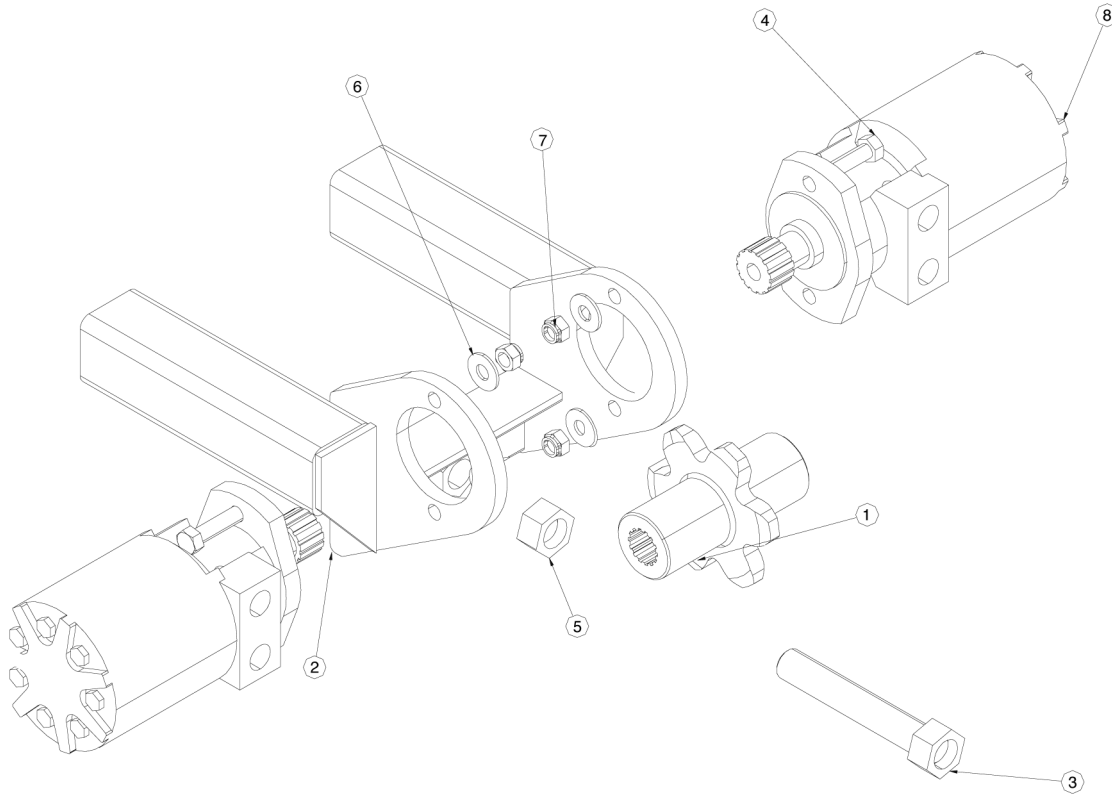

Item	Part Number	Description	Qty
1	C7031-00-26	Sprocket Drive Weldment	1
2	C7030-00-26	Motor 22.2 Cu Mt Weldment	1
3	C2768-00	Sprocket Adjusting Bolt Front 1 Nc	1
4	967275	Bolt Hex 0.500 Nc x 2.00 Gr8 (PI)	4
5	84051	Nut Hex Jam 1.00 Nc Gr2	1
6	84048	Washer 0.500 Flat SAE Bs (PI)	4
7	813663	Nut Lock (Steel) 0.500 Nc GrC (PI)	4
8	B2799-00	Motor 22.2 Cu	2

22510 Cylinder 3.0 Diameter Service Parts

	X2725	Seal Kit For B2799-00	1
--	-------	-----------------------	---

Carrier Hydraulic Assembly Drawing - Standard Configuration - A8000-04

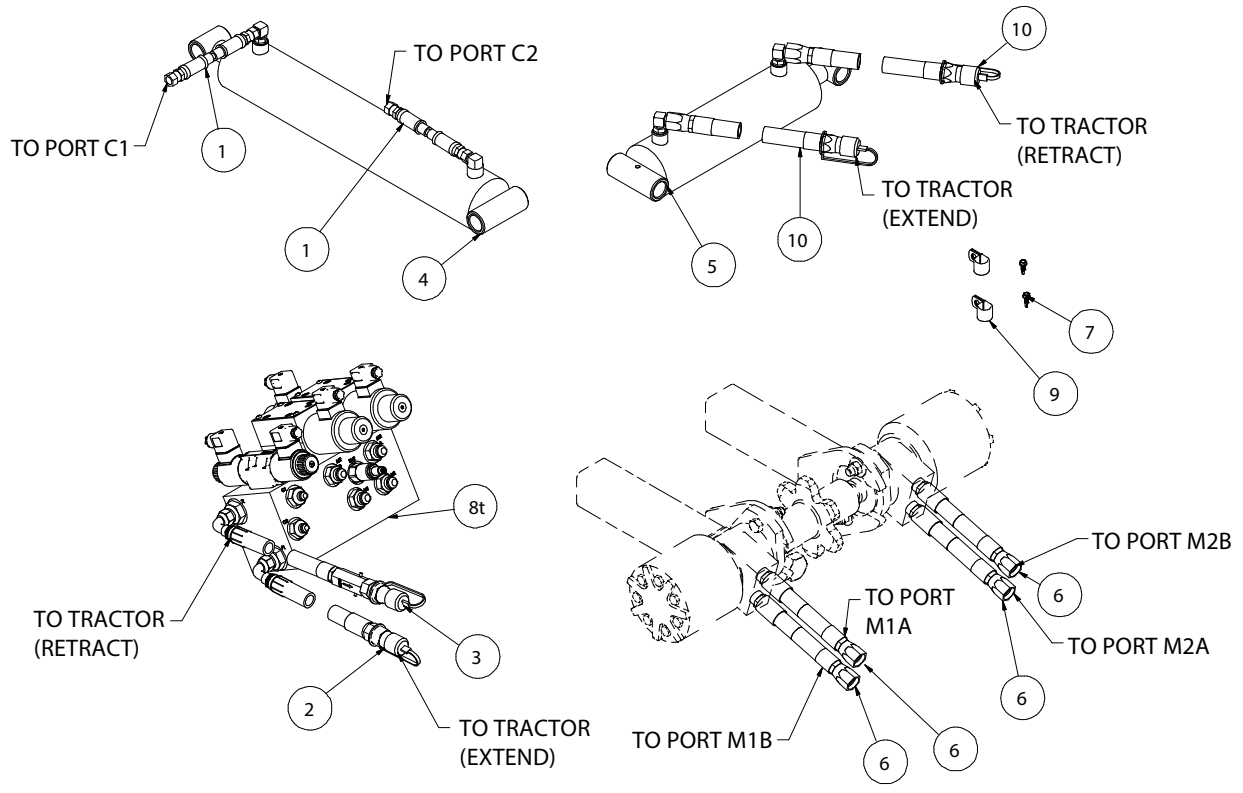

Item	Part Number	Description	Qty
1	115169	3/8" HOSE X 132" ASSY	2
2	815822	HYD ASSY 1/2 X 142 PRESS LINE	1
3	815823	HYD LINE 1/2in 142 RETURN LINE ASSY	1
4	A7013-00RH	TILT CYLINDER ASSEMBLY	1
5	A8012-00	TILT CYL. ASSEMBLY	1
6	SZ000512	HOSE 1/2 X 24 3/4SWFJIC X 7/8 MJIC	4
7	SZ000565	5/16-12 x 3/4 STAPSCW #3 PNT	2
8	SZ001266	VALVE BLOCK ASSEMBLY, 1450/2400	1
9	SZ103259	CLAMP HOSE TIE-DOWN	2
10	a8013-00	TILT CYL ASSY HYD 3/8 HOSE	2

Carrier Hydraulic Assembly Hardware Drawing - A8000-04

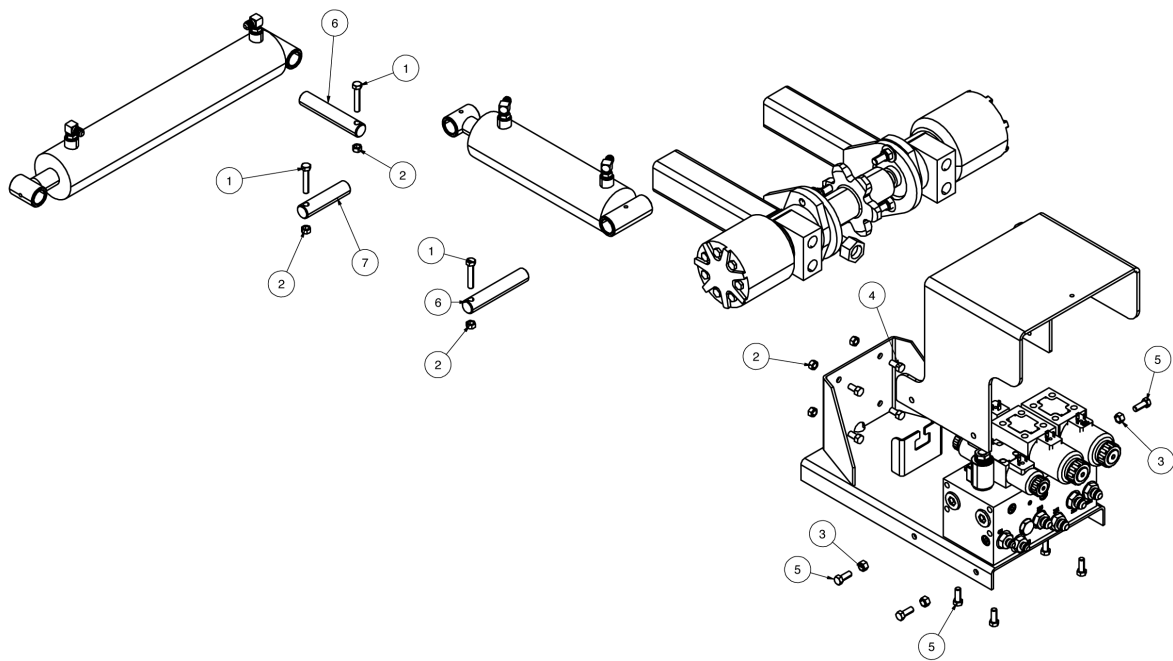

Item	Part Number	Description	Qty
1	811795	Bolt Hex 0.375 Nc x 2.00 Gr5 (PI)	3
2	812363	Nut Lock (steel) 0.375 GrB (PI)	7
3	81344	Nut Lock 0.375 Mc GrB (PI)	3
4	84072	Bolt Hex 0.375 x 0.75 Gr5 (PI)	4
5	86170	Bolt Hex 0.375 Nc x 1.00 Gr5 (PI)	7
6	E1932-00	Cylinder Pin 1.0 x 5 9/16	2
7	E2345-00	Pin Cylinder 1.0 Dia x 4.250	1

Carrier Bundled Assembly Drawing

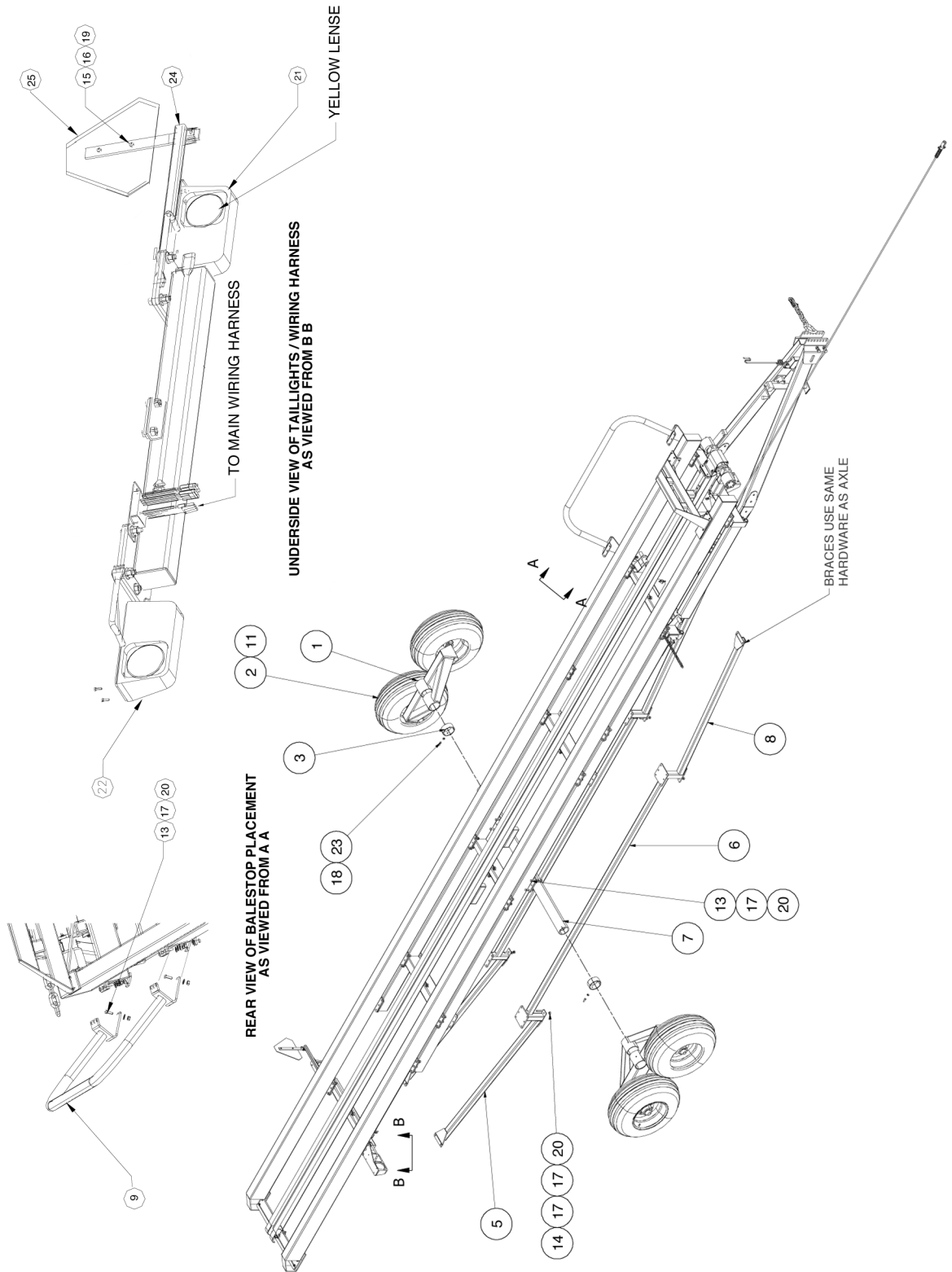

Item	Part Number	Description	Qty
1	B2400-14	Axle Assembly	2
2	B2700-03	Tire Assembly	4
3	C2407-00-26	Tandem Axle Locator	2
5	C7035-00-26	Rear Brace Weldment	2
6	C7036-00-26	Center Brace	2
7	815319-26	Axle	1
8	C8006-00-26	Front Brace Weldment	2
9	C8009-00-17	Bale Retainer Weldment	1
11	813653	Bolt 0.563 Nf x 1.75 (WB12)/Hub	24
13	967274	Bolt Hex 0.500 Nc x 1.50 Gr8 (PI)	34
14	81629	Bolt Hex 0.500 Nc x 3.5 Gr5 (PI)	14
15	81525	Bolt Hex 0.250 Nc x 0.75 Unc Gr5 (PI)	2
16	812624	Washer 0.250 Flat Bs (PI)	2
17	84048	Washer 0.500 Flat SAE Bs (PI)	42
18	984077	Nut Hex Jam 0.500 Nc Gr2 (PI)	43
19	81922	Nut Lock (Nylon) 0.25 Nc GrB (PI)	12
20	813663	Nut Lock (Steel) 0.500 Nc x 1.50 GrC (PI)	2
21	814196	Lamp-Ag/Dual/Lh/4-Way Wp	1
22	814195	Lamp-Ag/Dual/Rh/4-Way Wp	1
23	813547	Set Screw Sqhdcup 0.500 Nc	2
24	967075	SMV Spade Mount	1
25	967066	SMV Sign	1
	967275	Bolt Hex 0.500 Nc x 2.00 Gr8 (PI)	24

Tail Light Assembly Drawing - A8000-04

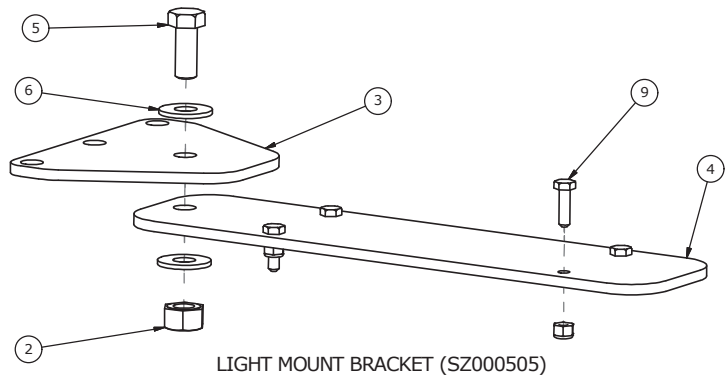
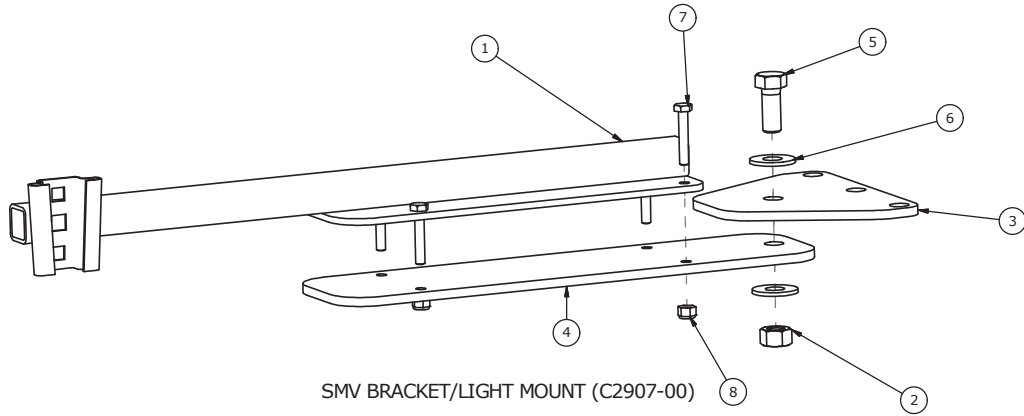

Item	Part Number	Description	Qty
1	SZ000507	Outer Light/SMV Bracket 1450	1
2	812364	1/2" Lock Nut (PI)	2
3	815372	Light Bracket Inner	2
4	815373	Light Bracket Outer	2
5	81620	1/2" x 1-1/4" Hex Bolt (PI)	2
6	84048	Washer 0.500 Flat SAE Bs (PI)	4
7	81529	Bolt Hex 0.250 Nc x 1.5 Lg Gr2 (PI)	4
8	81922	Lock Nut (Nylon) 0.25 Nc	8
9	81527	Bolt Hex 0.250 Nc x 1.0 Lg Gr5 (PI)	4

Carrier Final Assembly Drawing - A8000-04

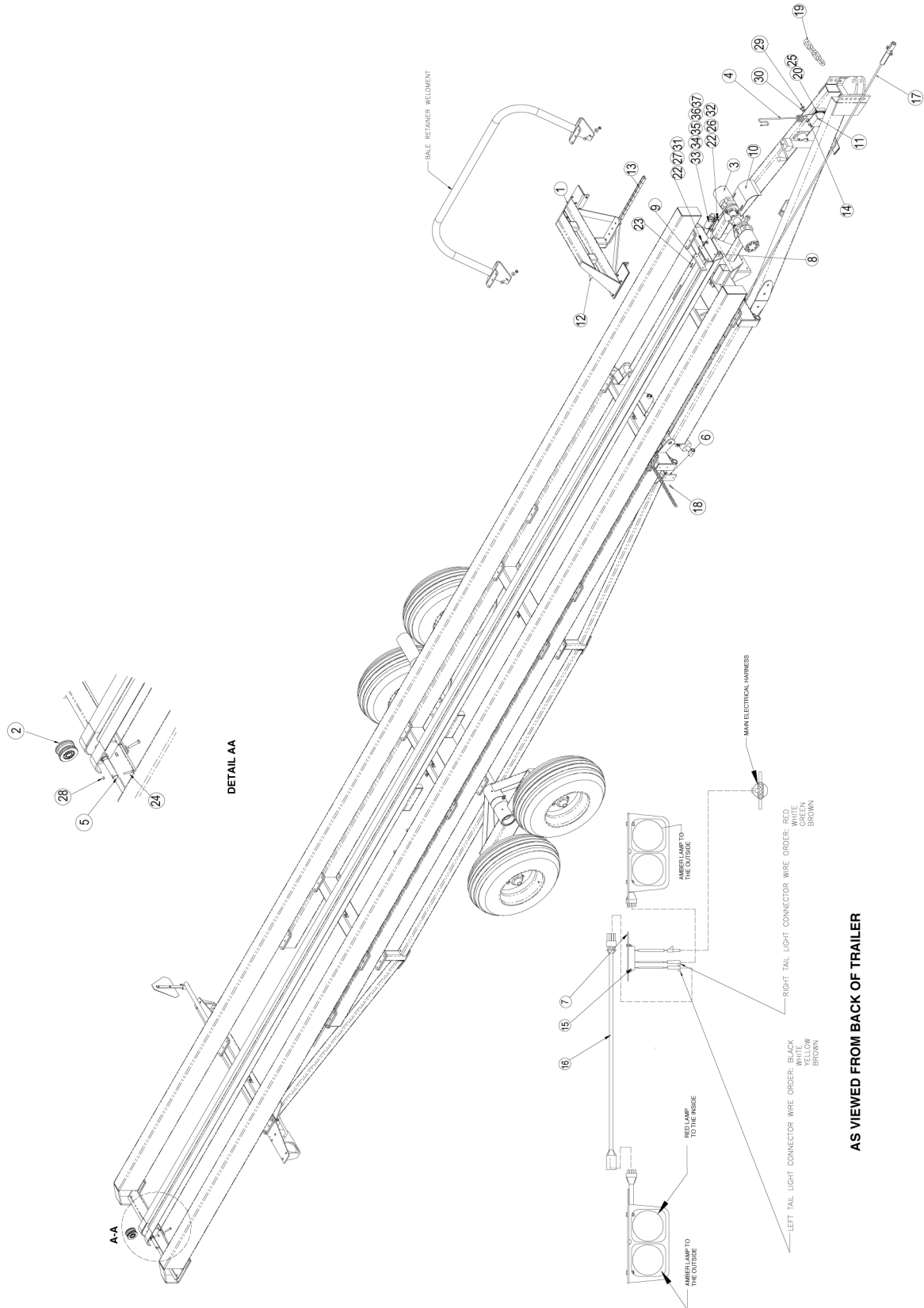

Item	Part Number	Description	Qty
1	A7006-00-17	Pusher Assembly	1
2	A7008-00	Chain Guide Roller Assembly	1
3	A8011-00	Motor Mount Assembly	1
4	813662	Hose Holder	1
5	E2345-00	Cyl Pin / 1.0" x 4-1/4"	1
6	E2413-00	Arm Cushion	1
7	E2937-00-26	Plate 1500/2500 Lighting Kit	1
8	E7038-00-26	Mounting Bracket/Shield	1
9	E7040-00	Cushion/Pusher Stop	1
10	E7039-00-26	Shield/Chain Drive	1
11	813949	Snubber Unit 1500/2500 Bale Carrier (Prior to S/N BM1450R13000001 & S/N BM1450S13000033)	1
12	813643	C2080H Connector Link HD	2
13	SZ000510	C2080H x 225 P + O/L + 1 CC/L	2
14	81620	Capscrew 0.500 Nc x 1.250 Gr5 Z (PI)	1
15	814193	Enhanced Ag Lighting Module	1
16	814199	Extension Harness 27" Long	1
17	814198	Main Harness 48 Ft Long 7 Pin Plug	1
18	813602	Rivet 1/4" x 3/4" Flhd	2
19	814434	Safety Chain 20M Gvw	1
20	813958	Screw Mach #8-32 x 0.75	6
22	81549	Bolt Hex 0.313 Nc x 0.75 Gr5 (PI)	6
23	81552	Bolt Hex 0.313 Nc x 1.25 Gr5 (PI)	2
24	811795	Bolt Hex 0.375 Nc x 2.00 Gr5 (PI)	1
25	812537	Nut Lock (Nylock) #8-32 Steel	6
26	84541	Nut Lock (Nylon) 0.313 Nc Gr8 (PI)	4
27	812362	Nut Lock (Steel) 0.313 Nc Gr8 (PI)	4
28	812363	Nut Lock (Steel) 0.375 Nc Gr8 (PI)	1
29	812364	Nut Lock (Steel) 1/2" Nc Gr8 Z (PI)	1
30	813581	Washer Flat 0.5 x 0.531 x 0.25 (PI)	1
31	81570	Washer Flat Std 0.375 Hs (PI)	4
32	81546	Washer 0.313 Flat Std Hs (PI)	1
33	909277	Manual Holder	1

Carrier Initial Assembly Drawing - A8000-04

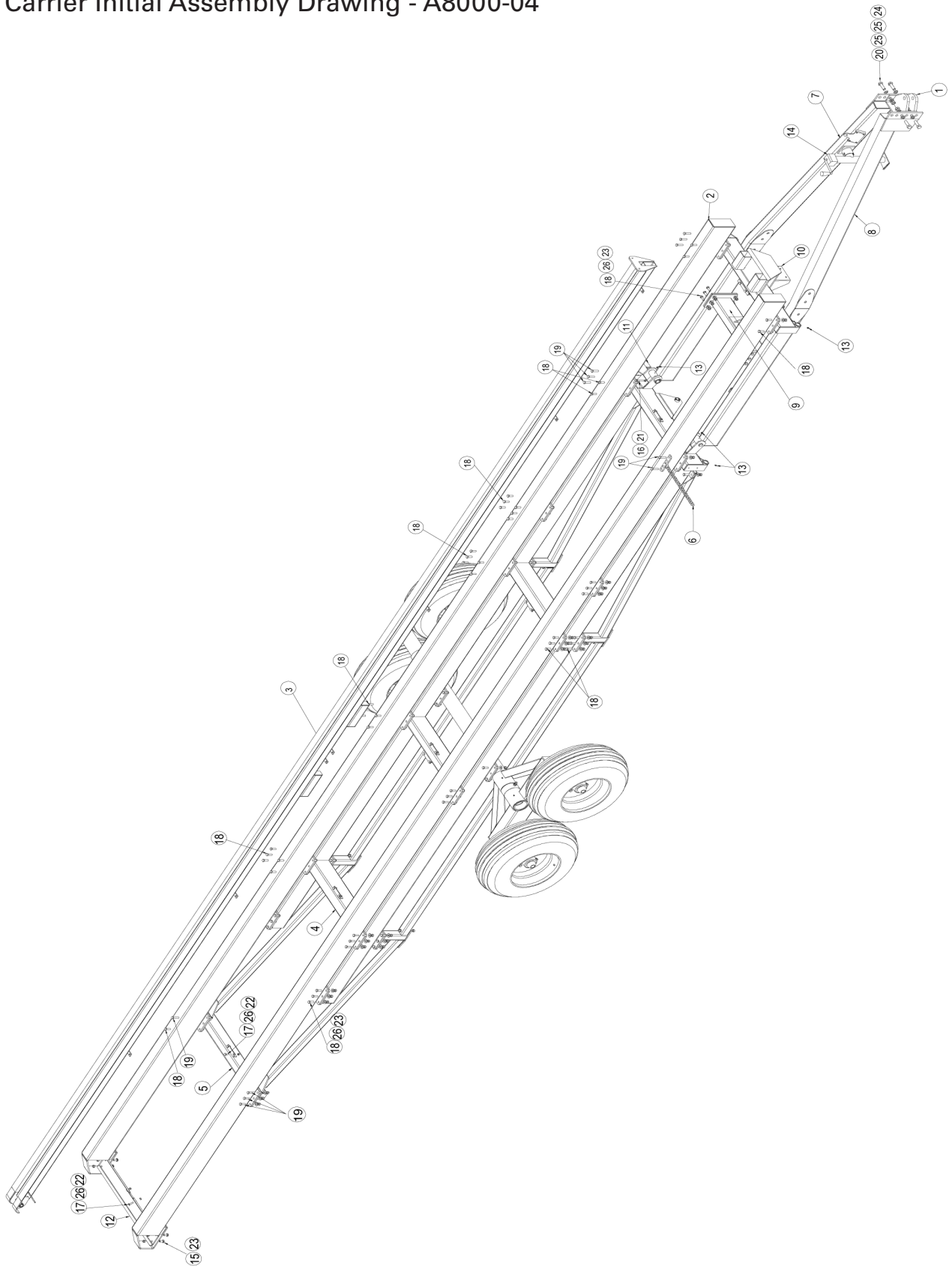

Item	Part Number	Description	Qty
1	SZ000561-26	Perfect Hitch	1
2	C7055-00-26	Outer Carrier Beam	2
3	C7057-01-26	Chain Guide Weldment	1
4	C8003-01-26	Subframe	1
5	C8004-01-26	Rear Crossmember	1
6	815829	Chain Weld't, Lift Arm	1
7	C8014-00-26	L.H. Hitch Beam	1
8	C8015-00-26	R.H. Hitch Beam	1
9	C8016-00-26	Hitch Crossmember Weldment	1
10	C8017-01-26	Front Crossmember	1
11	E2445-00	Lift Arm Pin	2
12	INE7003-01-26	Rear Chain Crossmember	1
13	813646	Grease Fitting 0.250 NF Driven	4
14	813647	Screw Jack 3.50 Ton	1
15	812288	Bolt Carr 0.500 Nc x 1.25 Gr5 Z (PI)	4
16	81581	Bolt Hex 0.375 Nc x 2.50 Gr5 (PI)	2
17	81620	Bolt Hex 0.500 Nc x 1.25 Gr5 (PI)	16
18	967274	Bolt Hex 0.500 Nc x 1.50 Gr8 (PI)	78
19	967275	Bolt Hex 0.500 Nc x 2.00 Gr8 Z (PI)	16
20	813515	Bolt Hex 0.750 Nc x 2.50 Gr8 (PI)	4
21	812363	Nut Lock (Steel) 0.375 Nc Gr8 (PI)	4
22	812364	Nut Lock (Steel) 0.500 Nc Gr8 (PI)	16
23	813663	Nut Lock (Steel) 0.500 Nc Gr8 (PI)	98
24	813648	Nut Lock (Steel) 0.750 Nc Gr8 (PI)	4
25	813590	Washer Flat 1.25 x 0.781 x 0.25 (PI)	8
26	84048	Washer Flat SAE 0.500 Bs (PI)	110

Complete Tandem Axle Assembly Drawing

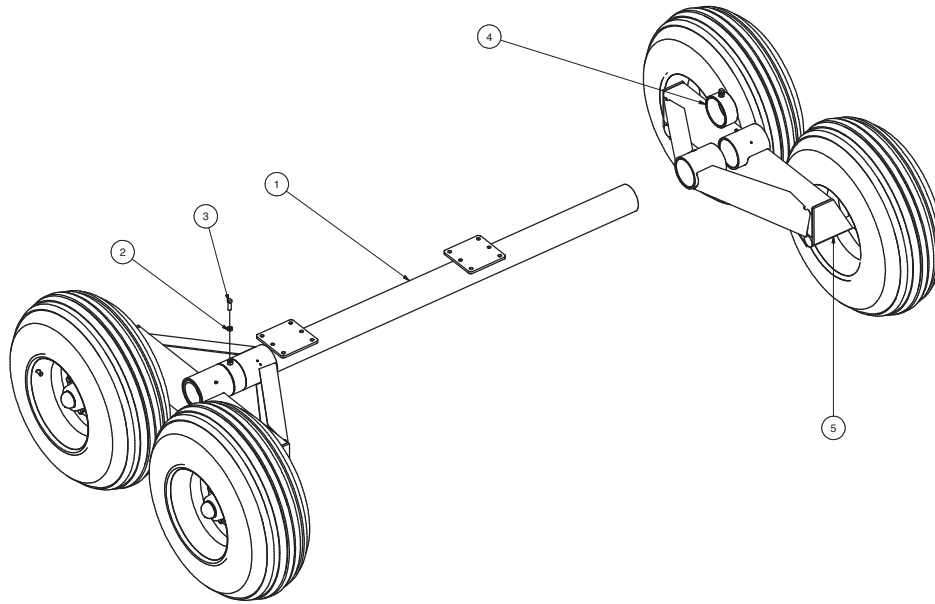

Item	Part Number	Description	Qty
1	815319-26	Axle Beam Weldment	1
2	984077	Nut Hex Jam 0.500 Nc Gr2 (PI)	2
3	813547	Setscrew Sq HD Cup 0.500 Nc	2
4	C2407-00-26	Tandem Axle/1500 Locator Weldment	2
5	B2400-14	Axle Assembly	2

Tire Assembly Drawing - B2700-03

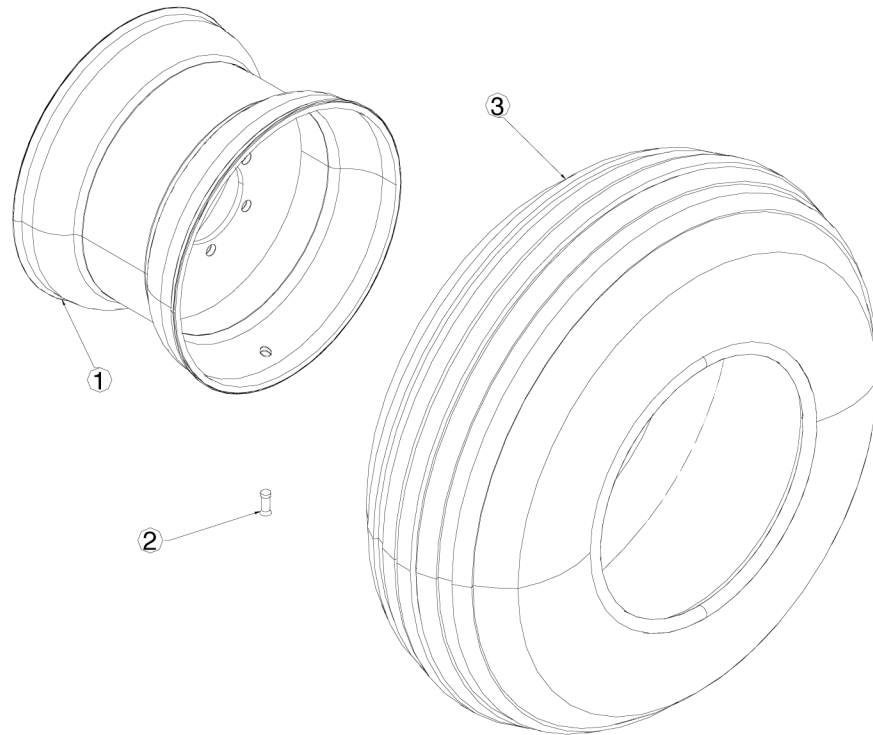

Item	Part Number	Description	Qty
1	813655	15 x 10 lb x 6 Bolt P65 Rim	4
2	813656	Tr-416-Ms Valve Stem w/ Cap	4
3	813657	Tire 12.5 x 15 FI 12 Ply Range F Farm Hwy Tire	4

Tandem Axle Assembly Drawing - B2400-14

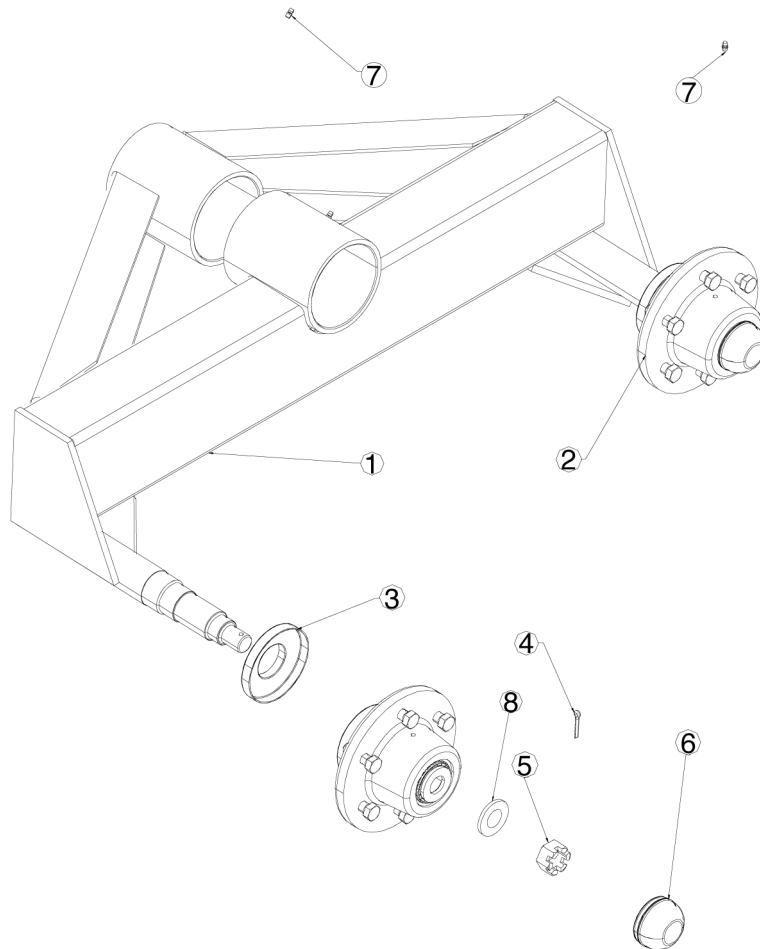

Item	Part Number	Description	Qty
1	C2406-00-26	Tandem Axle 1500 Weldment	1
2	C2339-00	Hub Assembly	2
3	813649	Dust Shield	2
4	81206	3/16" x 1-1/2" Cotter Pin Black	2
5	813673	Nut Castle 1.00 Nf	2
6	813650	Dust Cap	2
7	813646	Grease Fitting 1/4 Driven	4
8	813651	Washer Flat 1-1/32" x 2" x .188" Blk	2

Hub Assembly Drawing - C2339-00

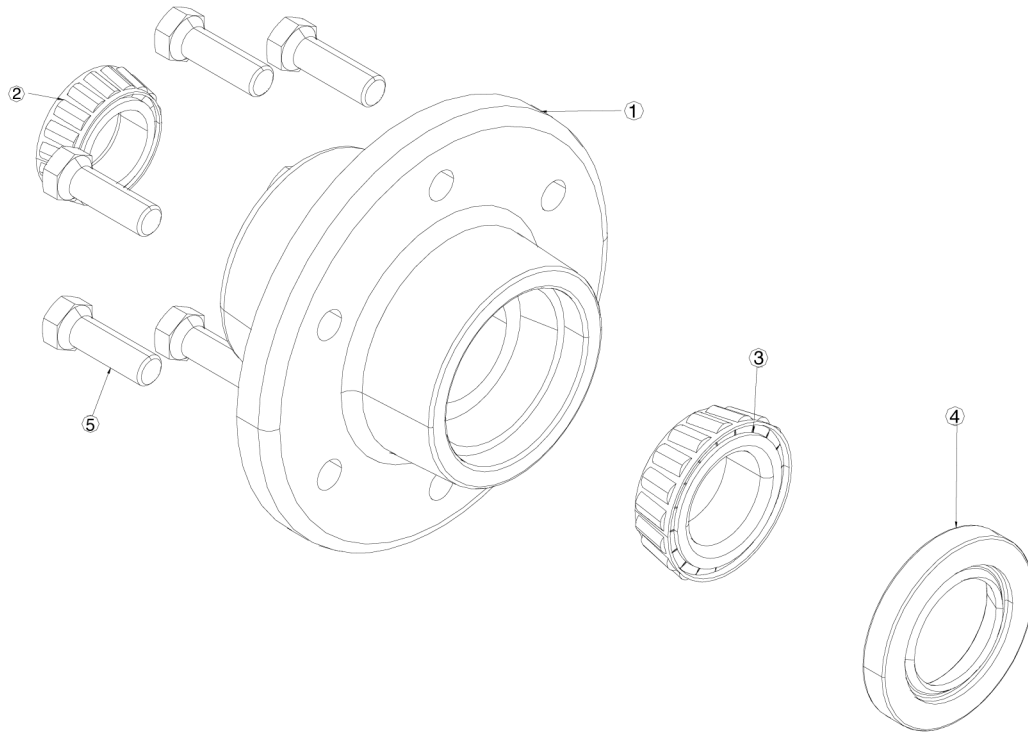

Item	Part Number	Description	Qty
1	813652	6 Bolt Wheel Hub	1
2	967205	Bearing Cone Outer	1
3	967208	Bearing Cone Inner	1
4	967204	Oil Seal SAE-30	1
5	813653	9/16" Hub Bolt	6

Pusher Assembly Drawing - A7006-00

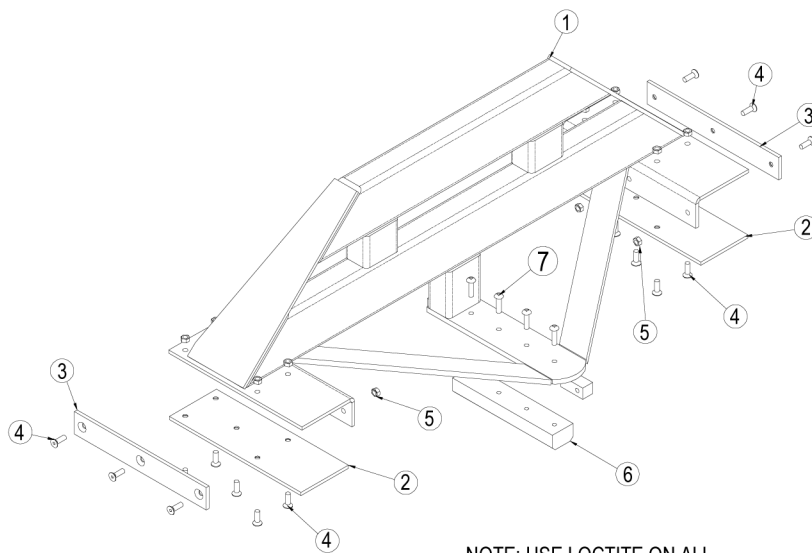

NOTE: USE LOCTITE ON ALL BRASS SCREWS

Item	Part Number	Description	Qty
1	C7027-00-17	Pusher	1
2	E2749-00	Top Slider	2
3	E2750-00	Side Slider	2
4	813558	Screw Mach M8 x 20 Flhd Brass	16
5	813561	Nut Hex M8 Brass	16
6	E7032-00	Center Slider	1
7	813644	Screw Mach 0.313 Nc x 1.25 Rdhd	4

Bale Stop Bundle Drawing - A8003-00

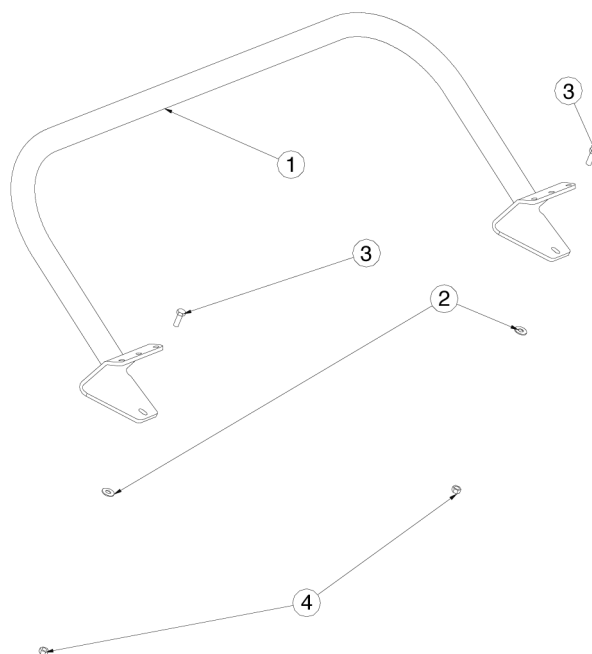

Item	Part Number	Description	Qty
1	C8009-00-26	Bale Retainer Weldment	1
2	84048	Washer 0.500 Flat SAE Bs (PI)	2
3	84277	Bolt Hex 0.500 Nc x 1.50 Gr5 (PI)	2
4	812364	Nut Lock (Steel) 0.500 Nc GrB (PI)	2

Roller/Chain Guide Assembly Drawing - A7008-00

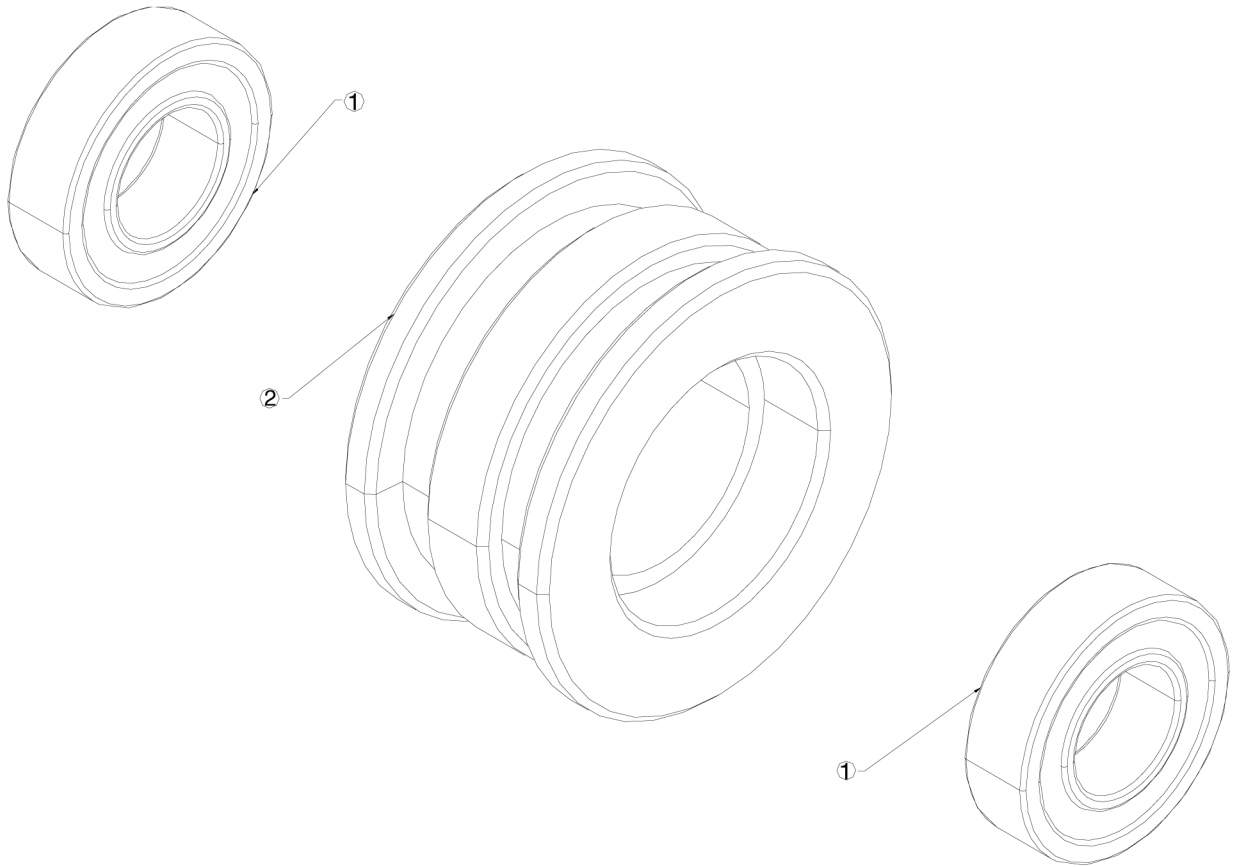

Item	Part Number	Description	Qty
1	813645	Bearing/6205LLU/25.4/3E	2
2	INE7037-00	Roller/Chain Guide	1

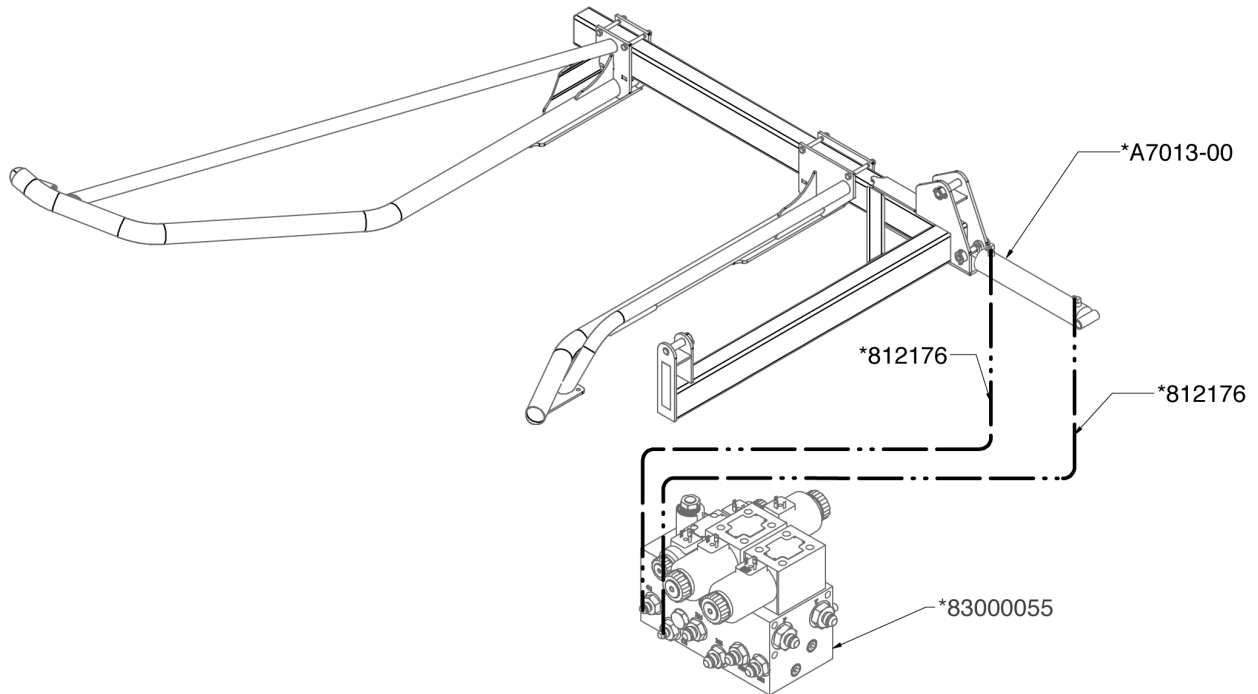
Fixed Pick Up Arm Hydraulic Assembly Drawing - A2300-87

- NOTES: 1) ALL ITEMS IN THE HYDRAULIC SCHEMATIC THAT ARE MARKED WITH A "*" ARE SUPPLIED ON THE MAIN FRAME ASSEMBLY.
2) LOOP ALL HOSES THROUGH APPROPRIATE HOSE HOLSTERS AND TIE WRAP.
3) DURING FIRST USE CHECK FOR CLEARANCE AND BINDING.

Fixed Pick Up Arm with Deflector RH Side Assembly Drawing - A2300-87

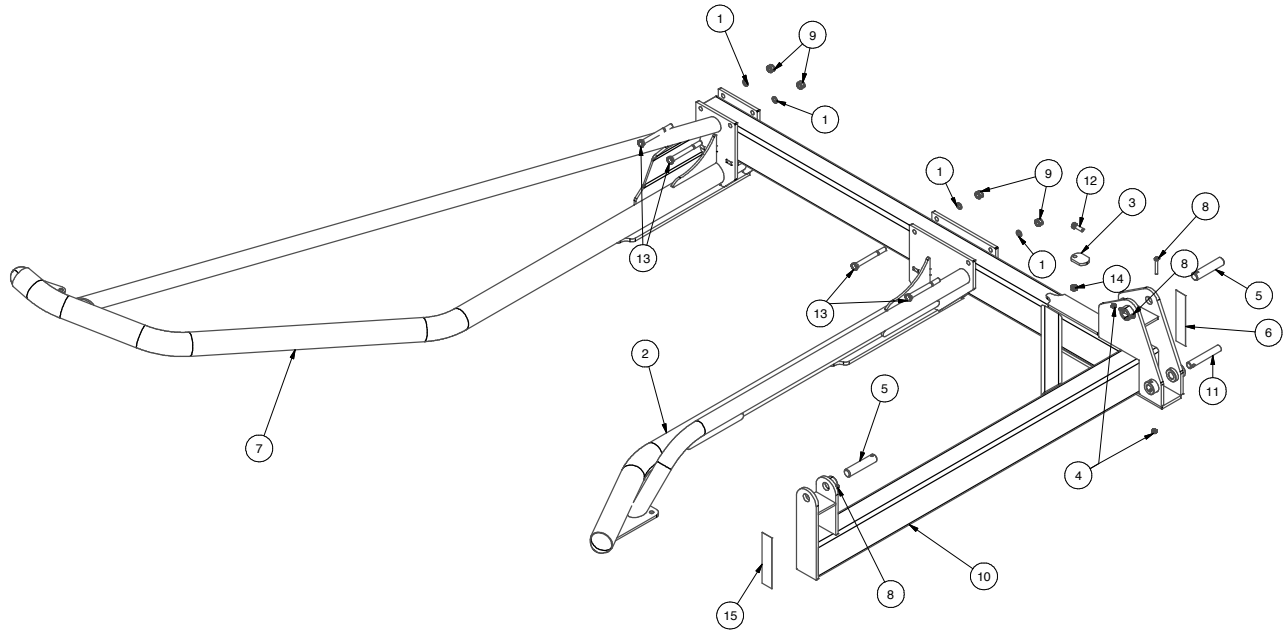

Item	Part Number	Description	Qty
1	81677	WASHER LOCK 0.625 PL	4
2	817621	WELDMENT - 2400 INSIDE FORK	1
3	E2485-00	CHAIN LATCH LIFT ARM	1
4	812363	3/8" LOCK NUT (PL)	3
5	E2445-00	PIN LIFT ARM 1.25 DIA C1045 CR	2
6	967053	DECAL REFLECTIVE 2 X 9 RED	1
7	817620	WELDMENT - QUARTER-TURN FORK	1
8	81581	HEX BOLT 0.375 X 2.50	3
9	813509	NUT HEX 0.625NC GR5 PL	4
10	SZ001224	RIGHT BALE LOADING ARM WLDT	1
11	E2912-00	PIN / HYD. CLY	1
12	84277	1/2" X 1 1/2" HEX BOLT (PL)	1
13	812087	5/8" X 6" HEX BOLT (PL)	4
14	812364	1/2" LOCK NUT (PL)	1
15	967055	DECAL REFLECTIVE 2 X 9 AMBER	1

RPU Squeeze Cylinder Drawing - A2300-35

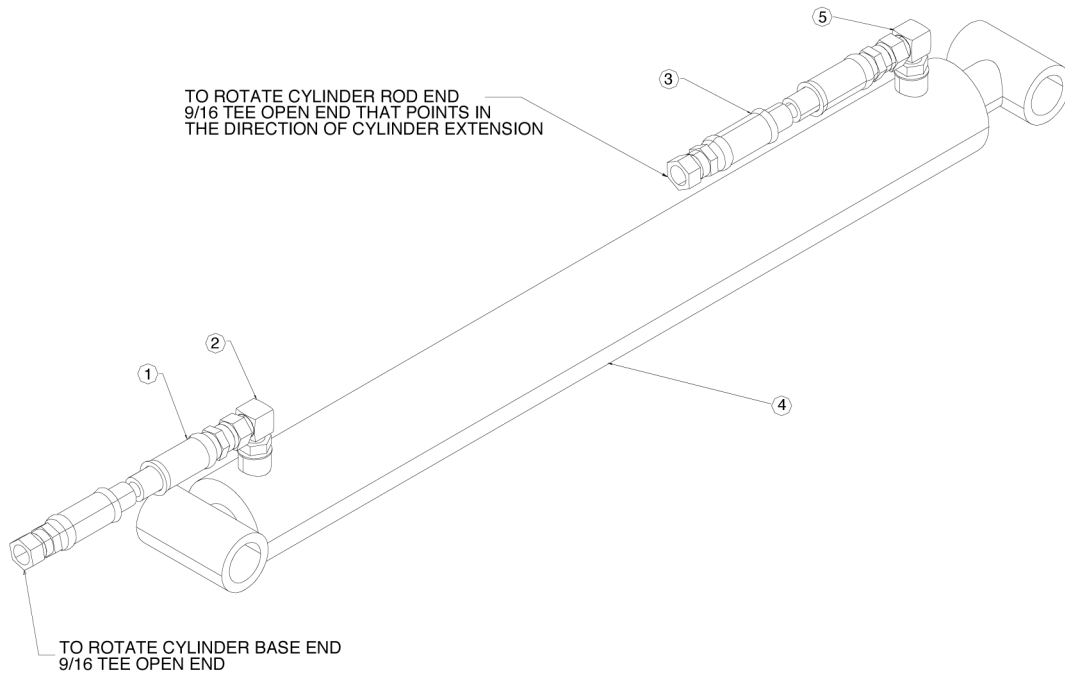

Item	Part Number	Description	Qty
1	IN29074	Hose 3/8 x 60 9/16 Swfjic	1
2	813640	Elbow 90 9/16 Morb Adj x 3/8	1
3	IN29067	Hose 3/8 x 68 9/16 Swfjic	1
4	24367	Cylinder 2.0 x 18.0 Inland	1
5	813640	Elbow 90° 9/16 Morb Adj x 3/8	2

24367 Cylinder 2.0 Diameter Service Parts

	811843	Not Grease Nipple 90°	1
	X1348	Seal Kit for 24367 2.0 Dia Cylinder	1
	83224	Backup Washer 1.75 Id x 2.00 Od	1
	812655	0.875 Unf Locknut	1
	114521	2.00 Dia Piston Half (Narrow)	1
	114520	2.00 Dia Piston Half (Wide)	1
	24366	2.00 Dia Tube Weldment	1
	115042	Shaft Weldment 1.25 Dia x 24.125 Lg	1
	24516	2.00 Dia Head Plate	1

Pilot Check Valve Assembly Drawing - SZ000658

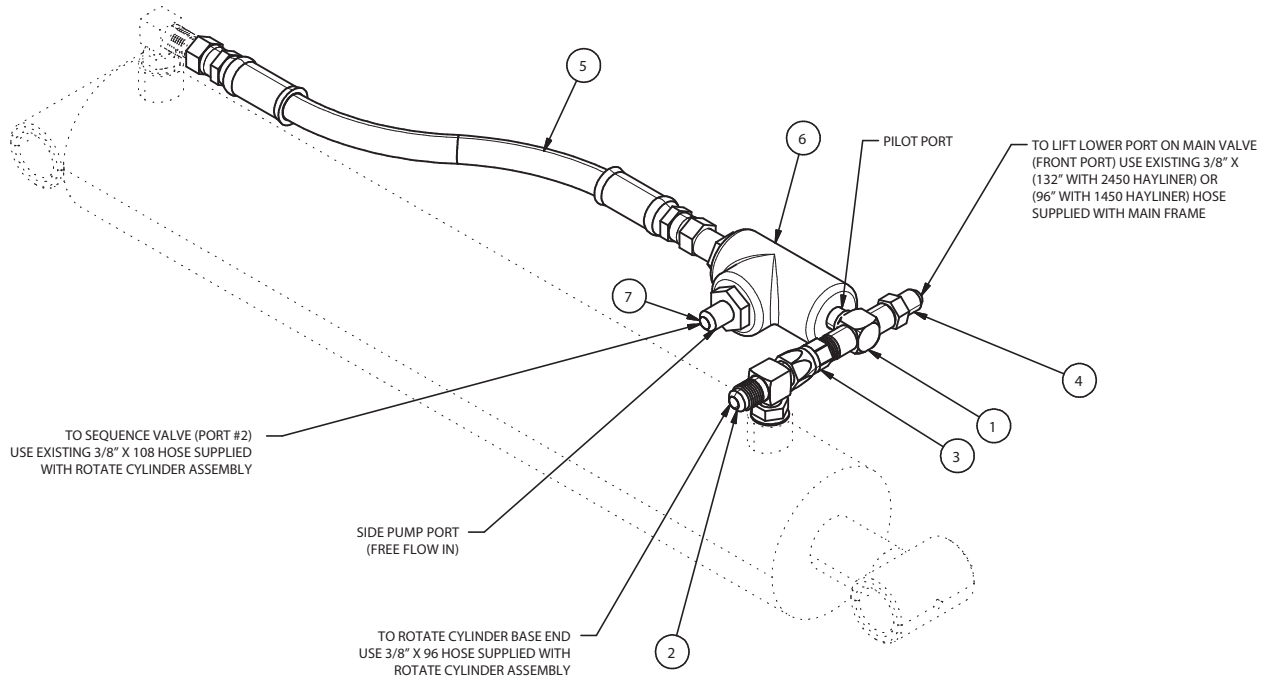

Item	Part Number	Description	Qty
1	29023	Tee 1/4" Fnpt Run x 1/4" Mnpt	1
2	29015	Tee 9/16" Mjic Run x 9/16" Morb	1
3	29039	Adaptor Str 1/4" Mnpt x 9/16" Fjic	1
4	29020	Connector 9/16" Mjic x 1/4" Mnpt	1
5	SZ000659	Hose 3/8" x 14-3/8" Fnpt x 9/16" Swfjic	1
6	SZ000661	Pilot Check Valve, PC50C	1
7	SZ000660	Adaptor Str, 3/8" Mjic x 1/2" Npt	1

RPU Rotate Cylinder Drawing - A2400-36

NOTES: 1) REMOVE TIE ROD SUPPLIED BY MANUFACTURER AND REPLACE WITH MANUFACTURED TIE ROD (ITEM 16). USE NEW ROD TO MOUNT SEQUENCE VALVE HOLDER (ITEM 15).

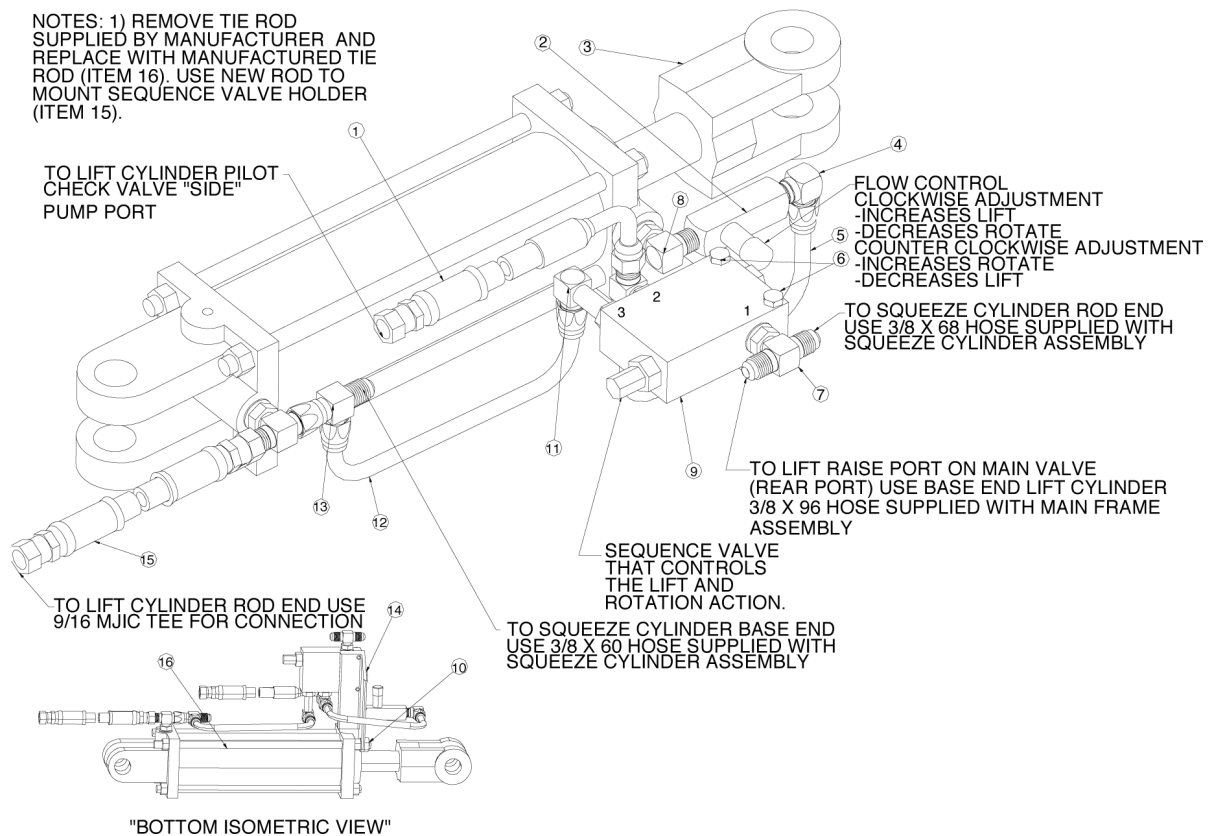

Item	Part Number	Description	Qty
1	29150	Hose 3/8 x 108 9/16 Swfjic x 3	1
2	29149	Restrictor One Way Adj Parker	1
3	22060	3 x 8 Tie Rod Cylinder	1
4	29016	Elbow 90 1/4 Mnpt x 9/16 Mjic	1
5	20877	Pressure Line / Sequence Tube	1
6	811631	Bolt Hex Jam 0.500 Nc Gr2 (PI)	2
7	29015	Tee 9/16 Mjic Run x 9/16 Mjic	3
8	29022	Elbow 90 1/4 Mnpt x 9/16 Morb	1
9	22075	Sun Sequence Valve Set 1800 PSI	1
10	984077	Nut Hex Jam 0.500 Nc Gr2 (PI)	1
11	29047	Elbow 90 9/16 Morb x 3/8 Mjic Lg	1
12	813691	Sequence Valve Vent Tube	1
13	887572	Tee 9/16 Mjic x 9/16 Swfjic	1
14	E2430-00	Sequence Valve Holder	1
15	812176	Hose 3/8 x 96 9/16 Swfjic x 3	1
16	E2478-00	Hydraulic Cylinder Tie Rod	1

22060 Cylinder 3.0 Diameter Service Parts

	22060-02	Seal Kit For 22060 Cylinder	1
--	----------	-----------------------------	---

RPU RH Side Assembly Drawing - A2400-32 - Optional

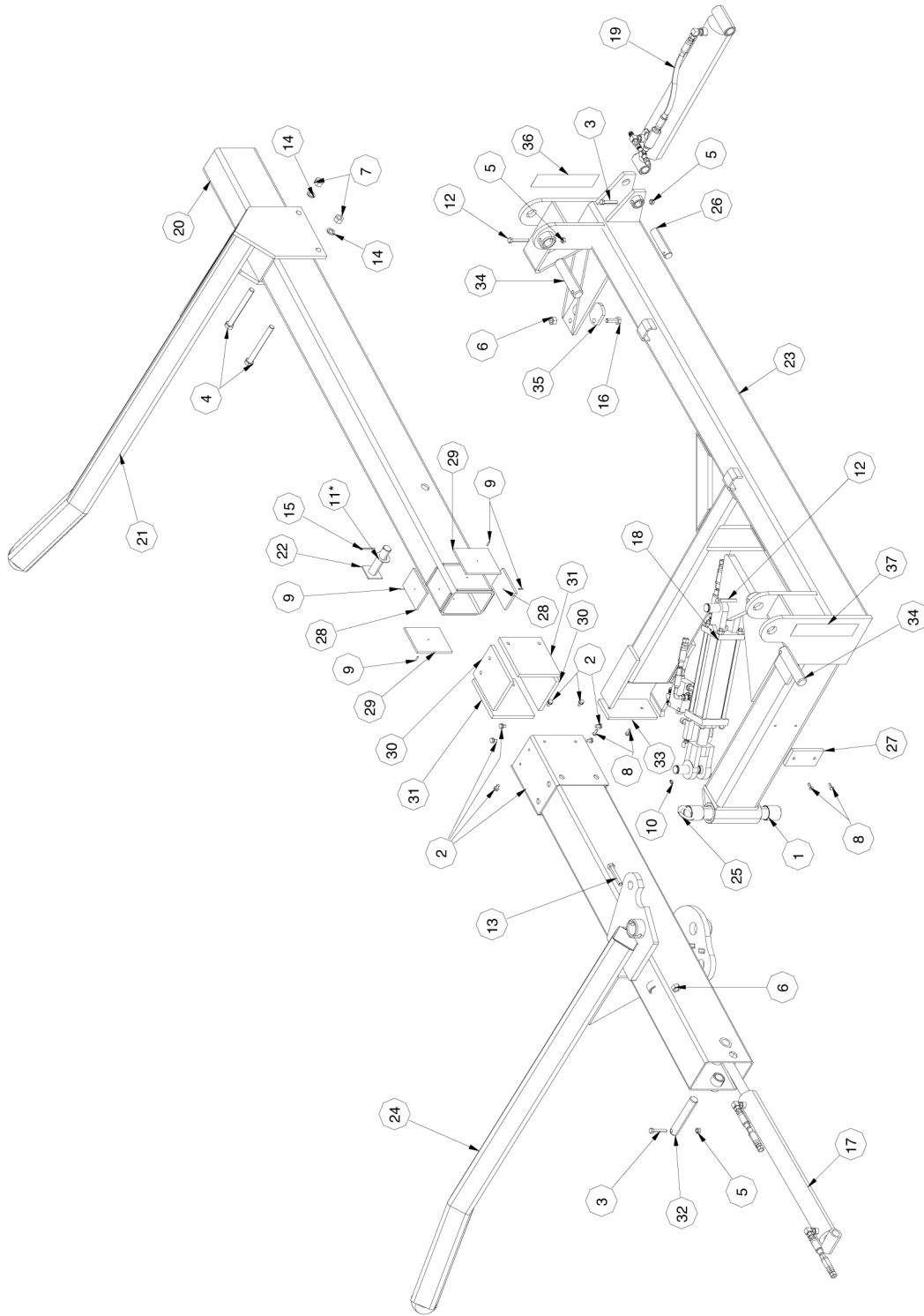

Item	Part Number	Description	Qty
1	20252	Bushing 1.75 Od x 1.5 Id x 1.75	2
2	810215	Screw SelfTap 0.313 Nc x 0.50	8
3	811795	Bolt Hex 0.375 Nc x 2.00 Gr5 (PI)	2
4	812087	Bolt Hex 0.625 Nc x 6.00 GrB (PI)	2
5	812363	Nut Lock (Steel) 0.375 GrB (PI)	4
6	812364	Nut Lock (Steel) 0.500 Nc GrB (PI)	2
7	813509	Nut Hex 0.625 Nc Gr5 (PI)	2
8	813602	Rivet 1/4 x 3/4 Flathead	4
9	813611	Pin Spring 0.125 Dia x 0.625 Long	4
10	813646	Grease Fitting 1/4 Nf Driven	1
11*	813795	Washer Flat 1.031 x 1.75 x 0.031	1
12	81581	Bolt Hex 0.375 Nc x 2.50 Gr5 (PI)	2
13	81626	Bolt Hex 0.500 Nc x 2.75 Gr5 (PI)	1
14	81677	Washer Lock 0.625 (PI)	2
15	81978	Cotter Pin 0.125 x 2.00 Poly	1
16	84277	Bolt Hex 0.500 Nc x 1.50 Gr5 (PI)	1
17	A2400-35	Squeeze Cylinder Assembly RPU	1
18	A2400-36	Rotate Cylinder Assembly RPU	1
19		Pilot Check Valve Assembly RPU (see page 59)	
20	C2417-00-26	Sliding Arm RPU	1
21	C2418-00-26	Fork Adjustable RH RPU	1
22	C2423-00	Pin Squeeze Cylinder RPU	1
23	C2499-00-26	Lift Arm Right	1
24	C2694-00-26	Rh Stationary Arm RPU	1
25	C2695-00	Pin Hinge RPU	1
26	E2345-00	Pin Cylinder 1.0 Dia x 4.5	1
27	E2413-00	Arm Cushion Rubber Belting	1
28	E2419-00	Arm Sliding Top & Bottom Pad	2
29	E2420-00	Arm Sliding Side Pad	2
30	E2421-00	Stationary Arm Top & Bottom RPU Pad	2
31	E2422-00	Arm Stationary Side RPU Pad	2
32	E2424-00	Pin Squeeze Cylinder Clevis	1
33	E2429-00	Arm Stationary Cushion RPU	1
34	E2445-00	Pin Lift Arm 1.25 Dia C1045CR	2
35	E2485-00-26	Chain Latch Lift Arm	1
36	967053	Decal Reflective 2 x 9 Red	1
37	967055	Decal Reflective 2 x 9 Amber	1

* Item #11 is use as needed

Hydraulic RPU Assembly Drawing - A2400-32 - Optional

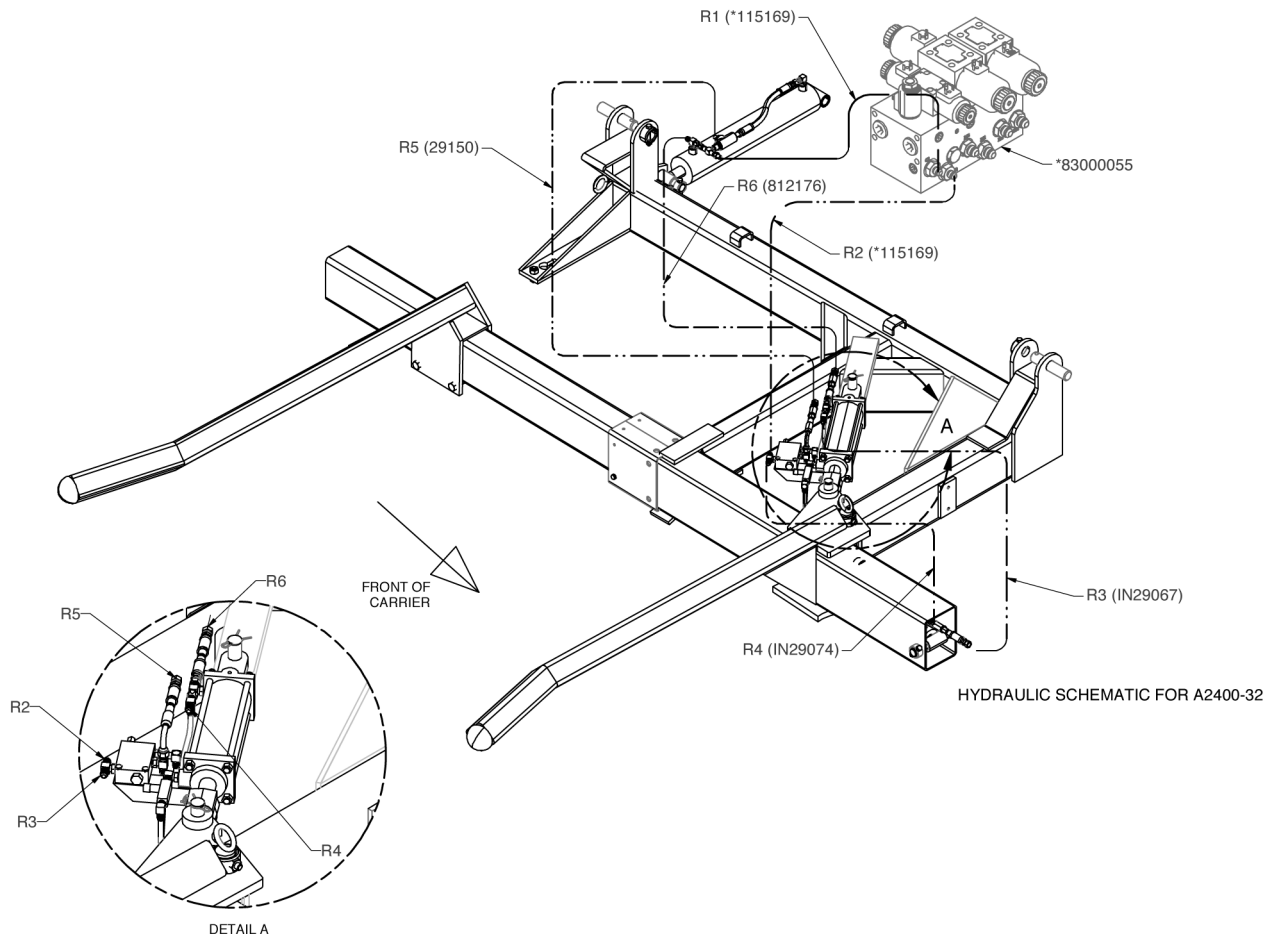

- NOTES: 1) THE LABELLED LINES IN THE SCHEMATIC CORRESPOND WITH THE PORTS IN DETAIL VIEWS A AND B. BRACKETS REPRESENT THE PART NUMBER.
 2) LOOP ALL HOSES THROUGH APPROPRIATE HOSE HOLSTERS AND TIE WRAP.
 3) CHECK FOR HOSE CLEARANCE AND BINDING DURING FIRST USE.
 4) ALL ITEMS THAT ARE MARKED WITH A "*" ARE SUPPLIED ON THE MAIN FRAME.

RPU Schematic

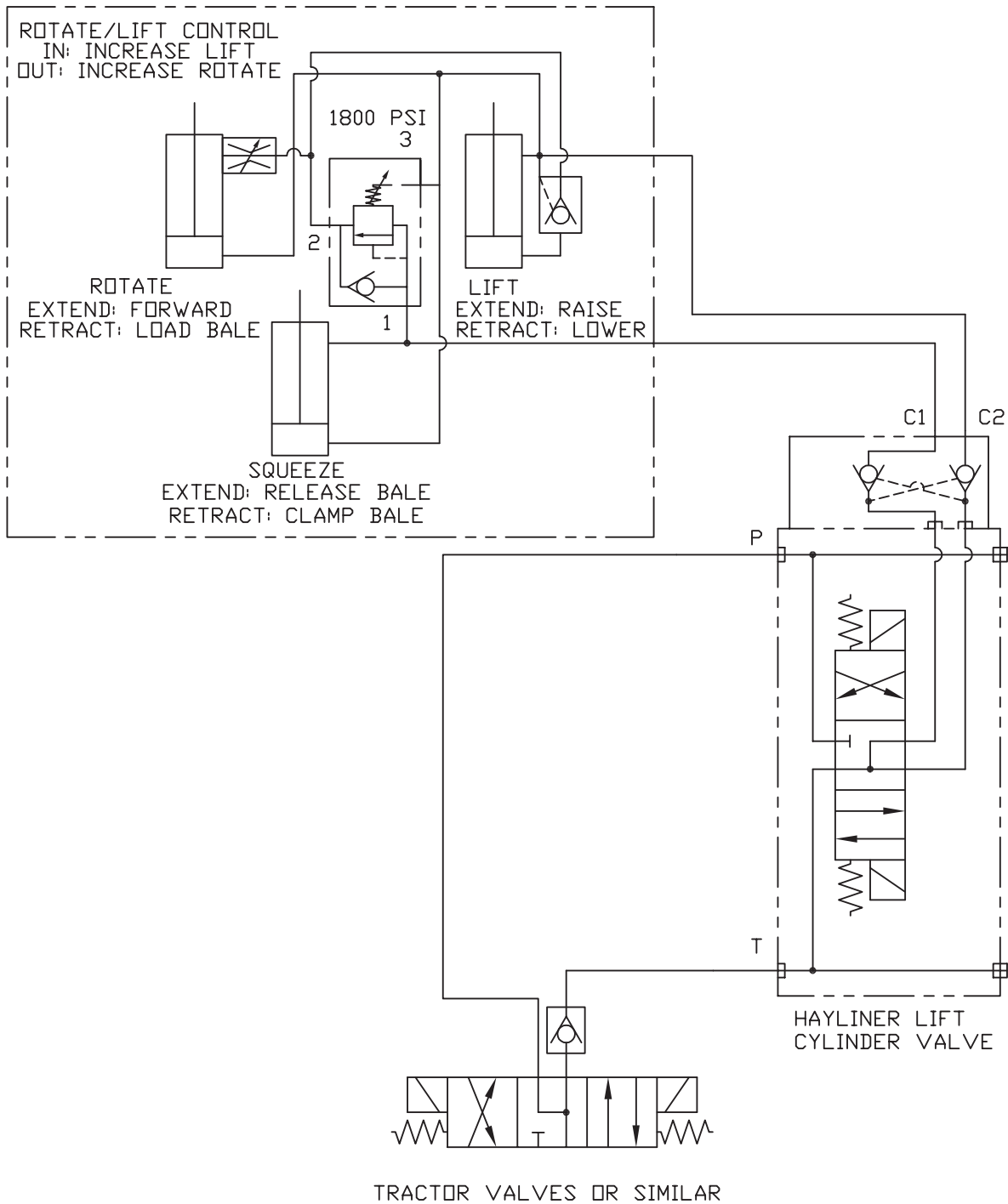

Optional Adjustable Bale Stop Assembly Drawing - 815692

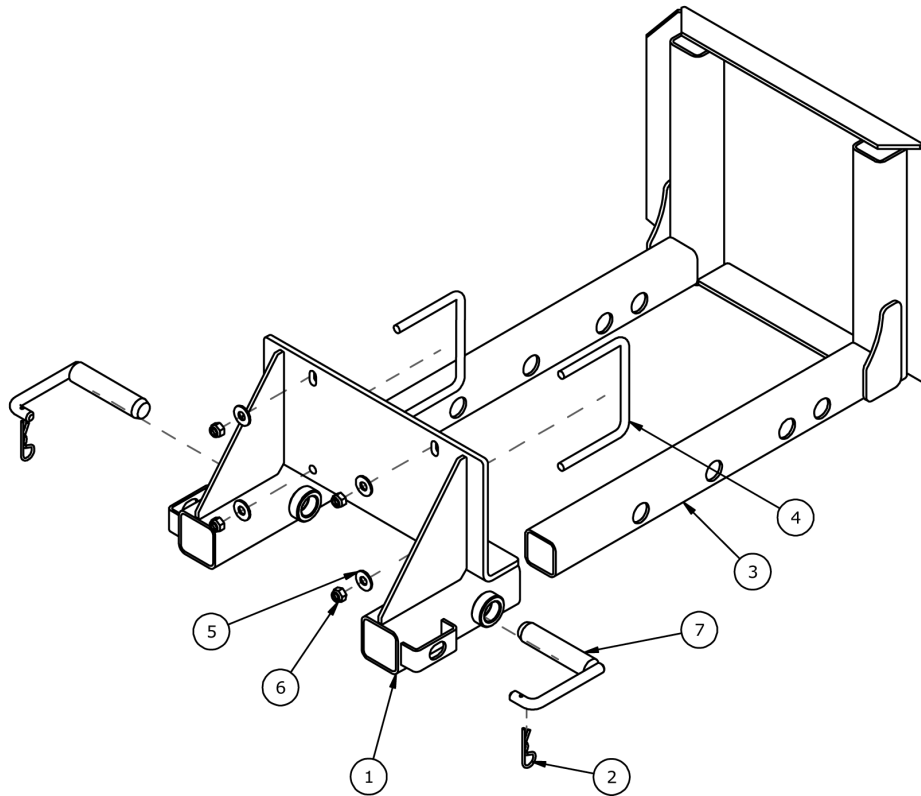

Item	Part Number	Description	Qty
1	815693-17	Bale Stop Bracket	1
2	12779	Hairpin Clip #9	2
3	815696-17	Bale Stop Weld't	1
4	815416	Valve Mount U-Bolt	2
5	84048	Washer 0.500 Flat SAE Bs (PI)	4
6	813663	Nut Lock (Steel) 0.500 Nc GrC (PI)	4
7	I20069	Locking Pin Bale Stop 4500	2

Optional Clevis Hitch Assembly Drawing - SZ000513

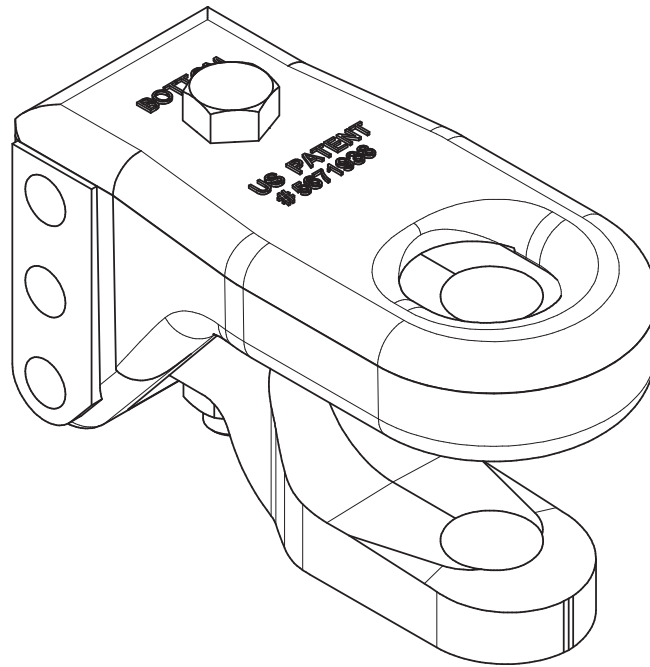

Item	Part Number	Description	Qty
1	SZ000513	Clevis Hitch Option Kit	1

Standard Hitch Assembly Drawing - SZ000561

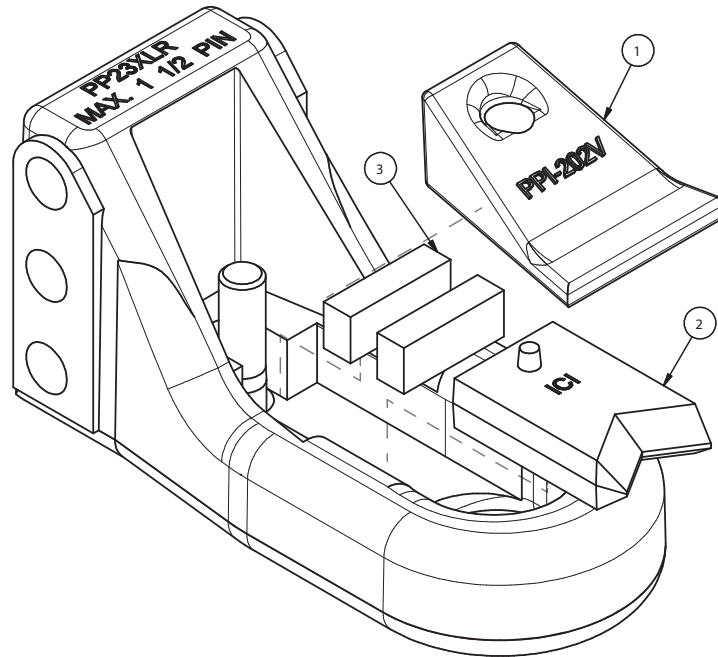

Item	Part Number	Description	Qty
1	SZ000569	Top Plate	1
2	SZ000570	V-block	1
3	SZ000571	Neoprene Cushions	2

Delivery Checklist

Pre-delivery

- Verify hardware torque.
- Verify rear wheel bolt torque
- Verify tire pressure
- Inspect bearing seals
- Inspect all lubrication points
- Inspect chain drives
- Inspect hydraulic hoses and electrical harnesses

Dealer Representative:

Date:

Customer Delivery

- Review safety procedures regarding bale carrier operation and maintenance
- Review Operator's and Part's Manual
- Review proper operating procedures
- Review general adjustment and setup procedures
- Review chain tensioning procedures
- Review importance of regular lubrication
- Discuss road and highway transportation requirements and regulations
- Review front hitch height

Dealer Representative:

Date:

Farm King Limited Warranty

This document limits your warranty rights.

Base Limited Warranty

Buhler Industries Inc. provides this warranty only to original retail purchasers of its product. Buhler Industries Inc. warrants to such purchasers that all Buhler Industries Inc. manufactured parts and components used and serviced as provided for in the Operator's Manual shall be free from defects in materials and workmanship for a period following delivery to the original retail purchaser of 12 months (80 days for commercial applications). This limited warranty applies only to those parts and components manufactured by Buhler Industries Inc. Parts and components manufactured by others are subject to their manufacturer's warranties, if any.

Buhler Industries Inc. will fulfill this limited warranty by, at its option, repairing or replacing any covered part that is defective or is the result of improper workmanship, provided that the part is returned to Buhler Industries Inc. within thirty (30) days of the date that such defect or improper workmanship is, or should have been, discovered. Buhler Industries Inc. reserves the right to either inspect the product at the buyer's location or have it returned to the factory for inspection. Parts must be returned through the selling representative and the buyer must prepay transportation charges.

Buhler Industries Inc. will not be responsible for repairs or replacements that are necessitated, in whole or part, by the use of parts not manufactured by or obtained from Buhler Industries Inc. Under no circumstances are component parts warranted against normal wear and tear. There is no warranty on product pump seals, product pump bearings, rubber product hoses, pressure gauges, or other components that require replacement as part of normal maintenance. Also: Buckets and Bucket Tines carry no warranty, Bent Spears carry no warranty, Snowblower Fan Shafts carry no warranty, Mower Blades carry no warranty, Portable Auger Parts Have Two (2) Year Warranty, Loader Parts Have Two (2) Year Warranty. The purchaser is solely responsible for determining suitability of goods sold. This warranty is expressly in lieu of all other warranties expressed or implied. Buhler Industries Inc. will in no event be liable for any incidental or consequential damages whatsoever. Nor for any sum in excess of the price received for the goods for which liability is claimed.

Repair Parts Limited Warranty

Buhler Industries Inc. warrants Farm King replacement parts purchased after the expiration of the Buhler Industries Inc. Limited Warranty, and used and serviced as provided for in the Operator's Manual, to be free from defects in materials or workmanship for a period of thirty (30) days from the invoice date for the parts. Buhler Industries Inc. will fulfill this limited warranty by, at its option, repairing or replacing any covered part that is defective or is the result of improper workmanship, provided that the part is returned to Buhler Industries Inc. within thirty (30) days of the date that such defect or improper workmanship is, or should have been, discovered. Such parts must be shipped to Buhler Industries Inc. at the purchaser's expense.

What is Not Covered

Under no circumstances does this limited warranty cover any components or parts that have been subject to the following: negligence; alteration or modification not approved by Buhler Industries Inc.; misuse; improper storage; lack of reasonable and proper maintenance, service, or repair; normal wear; damage from failure to follow operating instructions; accident; and/or repairs that have been made with parts other than those manufactured, supplied, and or authorized by Buhler Industries Inc.

Authorized Dealer and Labor Costs

Repairs eligible for labor under this limited warranty must be made by Buhler Industries Inc. or an authorized Farm King dealer. Buhler Industries Inc. retains the exclusive discretion to determine whether it will pay labor costs for warranty repairs or replacements, and the amount of such costs that it will pay and the time in which the repairs will be made. If Buhler Industries Inc. determines that it will pay labor costs for warranty work, it will do so by issuing a credit to the dealer's or distributor's account. Buhler Industries Inc. will not approve or pay invoices sent for repairs that Buhler Industries Inc. has not previously approved. Warranty service does not extend the original term of this limited warranty.

Warranty Requirements

To be covered by warranty, each Farm King new product must be registered with Buhler Industries Inc. within thirty (30) days of delivery to original retail purchaser. If the customer decides to purchase replacement components before the warranty disposition of such components is determined, Buhler Industries Inc. will bill the customer for such components and then credit the replacement invoice for those components later determined to be covered by this limited warranty. Any such replacement components that are determined not be covered by this limited warranty will be subject to the terms of the invoice and shall be paid for by the purchaser.

Warranty Claims:

Warranty requests must be prepared on Buhler Industries Inc. Warranty Claim Forms with all requested information properly completed. Warranty Claims must be submitted within a thirty (30) day period from date of failure repair.

Warranty Labor:

Any labor subject to warranty must be authorized by Buhler Industries Inc. The labor rate for replacing defective parts, where applicable, will be credited at 100% of the dealer's posted shop rate.

Exclusive Effect of Warranty and Limitation of Liability

TO THE EXTENT PERMITTED BY LAW, BUHLER INDUSTRIES INC. DISCLAIMS ANY WARRANTIES, REPRESENTATIONS, OR PROMISES, EXPRESS OR IMPLIED, AS TO THE QUALITY, PERFORMANCE, OR FREEDOM FROM DEFECT OF THE COMPONENTS AND PARTS COVERED BY THIS WARRANTY AND NOT SPECIFICALLY PROVIDED FOR HEREIN.

TO THE EXTENT PERMITTED BY LAW, BUHLER INDUSTRIES INC. DISCLAIMS ANY IMPLIED WARRANTIES OF MERCHANTABILITY AND FITNESS FOR A PARTICULAR PURPOSE ON ITS PRODUCTS COVERED HEREIN, AND DISCLAIMS ANY RELIANCE BY THE PURCHASER ON BUHLER INDUSTRIES INC.'S SKILL OR JUDGMENT TO SELECT OR FURNISH GOODS FOR ANY PARTICULAR PURPOSE. THE PURCHASER'S ONLY AND EXCLUSIVE REMEDIES IN CONNECTION WITH THE BREACH OR PERFORMANCE OF ANY WARRANTY ON PRODUCTS MANUFACTURED BY BUHLER INDUSTRIES INC. ARE THOSE SET FORTH HEREIN. IN NO EVENT SHALL BUHLER INDUSTRIES INC. BE LIABLE FOR INCIDENTAL OR CONSEQUENTIAL DAMAGES (INCLUDING, BY WAY OF EXAMPLE ONLY AND NOT LIMITATION, LOSS OF CROPS, LOSS OF PROFITS OR REVENUE, OTHER COMMERCIAL LOSSES, INCONVENIENCE, OR COST OF REPLACEMENT OF RENTAL EQUIPMENT). IN NO EVENT SHALL FARM KING'S CONTRACT OR WARRANTY LIABILITY EXCEED THE PURCHASE PRICE OF THE PRODUCT.

(Note that some provinces or states do not allow limitations on how long an implied warranty lasts or the exclusion or limitation of incidental or consequential damages, so the above limitations and exclusion may not apply to you.) This warranty gives you specific legal rights and you may also have other rights, which vary from province to province or state to state.

Buhler Industries Inc. neither assumes nor authorizes any person or entity, including its selling representatives, to assume any other obligations or liability in connections with the sale of covered equipment, or to make any other warranties, representations, or promises, express or implied, as to the quality, performance, or freedom from defect of the components and parts covered herein. No one is authorized to alter, modify, or enlarge this limited warranty, or its exclusions, limitations and reservations.

Corrections of defects and improper workmanship in the manner, and for the applicable time periods, provided for herein shall constitute fulfillment of all responsibilities of Buhler Industries Inc. to the purchaser, and Buhler Industries Inc. shall not be liable in negligence, contract, or on any other basis with respect to the subject equipment.

This limited warranty is subject to any existing conditions of supply which may directly affect Buhler Industries Inc.'s ability to obtain materials or manufacture replacement parts.

Buhler Industries Inc. reserves the right to make improvements in design or changes in specifications to its products at anytime, without incurring any obligation to owners of units previously sold.

Government Legislation:

Warranty terms and conditions are subject to provincial or state legislation.

Important Note: This warranty does not apply to rentals.

www.farm-king.com

Farm King

1330 43rd Street NW
Fargo, ND USA 58102
Ph.: 701.282.7014 | Fax: 701.282.5865
E-mail: info@buhler.com
www.farm-king.com

Equipment shown is subject to change without notice.
©2018 Buhler Trading Inc. Printed in USA. TSX:BUI

bühler | a division of Buhler Industries Inc.