

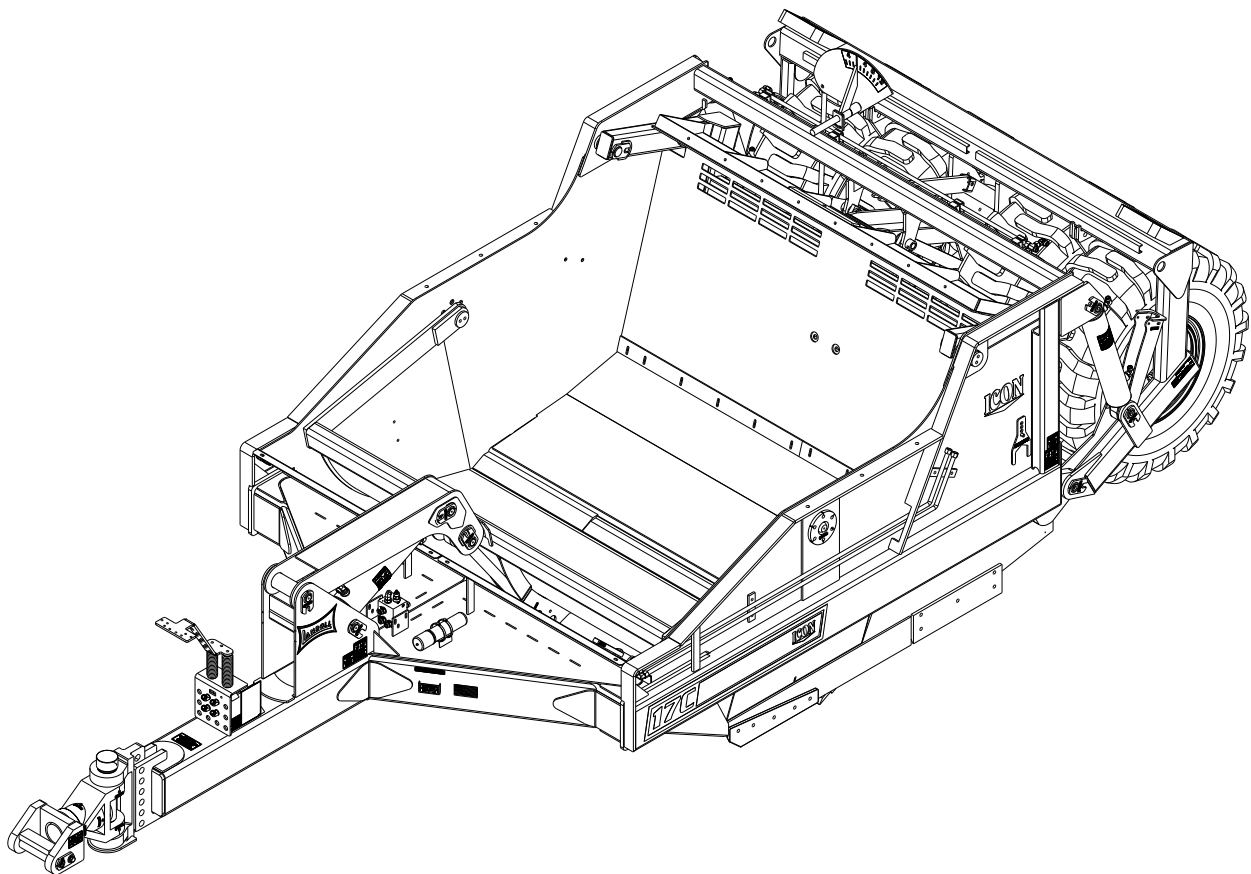

Model 17C/19C Scraper Service and Parts Manual



LANDOLL CORPORATION

1900 North Street

Marysville, Kansas 66508

(785) 562-5381

800-428-5655 ~ WWW.LANDOLL.COM

Safety Information

Introduction

This manual is compiled as a guide for owners and operators of the Scraper. Read it carefully so as to be able to follow the suggestions made. Please take time to understand the proper maintenance schedule and SAFE operation of your equipment.

In the event that a new and inexperienced operator is placed in charge of running the equipment, they should read and understand, that part of the manual for proper maintenance and SAFE operation, and to be trained in regard by an experienced operator.

Owner Assistance

If customer service or repairs are needed, contact your Icon dealer. They have trained personnel, parts and service equipment specially designed for Icon products. Your machine's parts should only be replaced with Icon parts. Have the Serial Number and complete Model Number available when ordering parts from your Icon dealer (**See Figure 2-1.**)

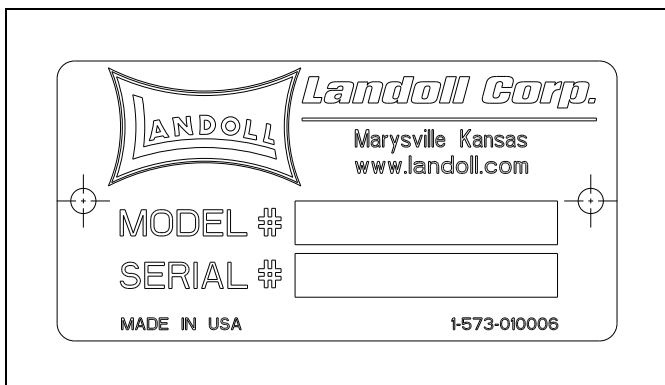

Figure 2-1: ID Plate

Warranty Registration

Be certain to register the grader, by Online registration at www.landoll.com within 10 days of purchase or lease, in order to be on file at Landoll and eligible for Warranty.

Take time to read and understand the Warranty for this product. That Warranty is printed in the Owner's Manual (**See Figure 2-2**), and a separate copy enclosed in the packet.

ICON/Landoll reserves the right to make changes and/or add improvements to its products at any time without obligation to previously manufactured equipment.

Please take time to complete the following information for your personal reference, should you need to contact your Dealer with questions or parts needs.

MODEL _____

SERIAL # _____

DATE OF PURCHASE _____

DEALER NAME _____

We at ICON/Landoll wish to thank you for purchasing our product. We have spent considerable time and effort to research, design, test and develop this machine and are confident it will serve you in the use for which it was designed.

LANDOLL CORPORATION

Product Warranty

LANDOLL CORPORATION 1600 W. 8th St. Beloit KS 67420
(referred to as LANDOLL in this document)

LANDOLL shall Warrant workmanship and materials on the **ICON Industrial Products** for a period of 270 calendar day from the date of original purchase, lease, or rental, from the original Dealer, and in accordance with the following terms and conditions.

Should any part or component fail within the Warranty period, and under normal use conditions, LANDOLL shall supply a new part or component for replacement through the original Dealer. Cost of normal ground freight, for that part or component to the Dealer, shall be paid by LANDOLL. Repair and replacement labor cost, from the original Dealer, shall be paid by LANDOLL at a rate negotiated by LANDOLL.

No further expense shall be paid by LANDOLL, including but not limited to, loss of time or income.

LANDOLL shall not provide Warranty on any part or component that has failed due to abuse, misuse, alteration, improper maintenance, or normal wear. Failure occurring while being pulled by a tractor in excess of engine horsepower, as described in the owners manual and/or posted on the machine, is considered abuse and misuse and shall not receive Warranty. Warranty applies only to normal, intermittent agricultural use, and not commercial or industrial use.

In regard to some components manufactured by other companies and sold by LANDOLL, including but not limited to tires, said Warranty shall be provided solely by that manufacturing company.

This Warranty applies to products sold in the United States and Canada, and is made expressly in place of all other warranties, expressed or implied.

Figure 2-2: Product Warranty

Understanding Safety Statements

You will find various types of safety information on the following pages and on the machine decals (signs) attached to the implement. This section explains their meaning.

NOTICE

Special notice - read and thoroughly understand.



CAUTION

Proceed with caution. Failure to heed caution may cause injury to person or damage product.



WARNING

Proceed with caution. Failure to heed warning will cause injury to person or damage product.



DANGER

Proceed with extreme caution. Failure to heed notice will cause injury or death to person and/or damage product.

NOTE

Means that failure to follow these instructions could cause damage to the equipment or cause it to operate improperly.

NOTE

Make sure you read and understand the information contained in this manual and on the machine signs (decals) before you attempt to operate or maintain this vehicle.

The safety statements contained in this manual relate to the operation of the Grader.

NOTE

You should read and understand the information contained in this manual and on the machine decals before you attempt to operate or maintain this equipment.

- Examine safety decals and be sure you have the correct safety decals for the machine. Order replacement decals through your Icon dealer.
- Keep these signs clean so they can be observed readily. It is important to keep these decals cleaned more frequently than the machine. Wash with soap and water or a cleaning solution as required.
- Replace decals that become damaged or lost. Also, be sure that any new machine components installed during repair include decals which are assigned to them by the manufacturer.
- When applying decals to the machine, be sure to clean the surface to remove any dirt or residue. Where possible, sign placement should protect the sign from abrasion, damage, or obstruction from mud, dirt, oil etc.



DANGER

- **Keep Riders Off of Machinery**
- **Do not allow anyone to ride on tractor or machine. Riders could be struck by foreign objects or thrown from the machine.**
- **Never allow children to operate equipment.**
- **Keep bystanders away from machine during operation.**

Safety Decals

See Decal Listing for decal locations.

NOTE

Replace all missing or damaged safety signs/decals.

Pinching or Crushing Danger

1. Moving parts that are operated by hydraulic pressure can cause serious injury or death.
2. Use extreme caution when working around any moving part.
3. Do not allow any person to be on or near the machine while it is in motion.

Moving Parts

1. Be aware of all moving parts of the machine.
2. Do not allow anyone to be near, or on the machine while operating any moving part.

Danger

1. Read and understand the operator's manual before using the machine.
2. Allow no person to operate the machine before reading the manual and being instructed on proper operation.

Caution

1. This machine is designed for off road use only.

Danger, High Pressure

1. High pressure fluid can cause serious damage to hands and eyes.
2. Carefully relieve pressure before attempting any
3. adjustments.
4. Tighten all fittings before applying pressure.

NOTE

*If fluid is sprayed into eyes or injected into skin, **see a doctor immediately!***

Lubrication

1. Lubrication information is placed near each zerk.
2. Proper maintenance should be followed to assure the working life of the machine.

Proper Notification

1. Contact the proper authorities before you dig.
2. When digging in a populated area, it is recommended that a call be made to area utilities to establish the local of any buried pipes, lines, or structures. When digging in open areas, research and know the local of any underground structures and objects.
3. Striking the blades or bits against buried objects can cause damage to the machine, and is considered as abuse to the unit.

Storage Recommendations

NOTE

If the machine is being stored or not in use for a long period of time, it is recommended that a coating of heavy grease be applied to the exposed chrome cylinder rods. This will help to protect the coating from moisture and rust during this time.

Standard Specifications

Model Specification

Specification		
	Model 17C	Model 19C
Capacity Struck	13.6 yd	16.9 yd
Capacity Heaped	17 yd	19 yd
Shipping Weight	23,200 lbs	23,900 lbs
Width of Cut	10'	11'
Overall Width	10' - 11"	11' - 11"
Transport Height	8' - 10"	8' - 10"
Replaceable Cutting Edge Center	7/8" X 16" X 48"	7/8" X 16" X 60"
Replaceable Cutting Edge Outside	7/8" X 13" X 35.75"	7/8" X 13" X 35.75"
Ground Clearance Full Raised	18"	18"
Maximum Cut Depth	9"	9"
Length Overall	27' - 6"	27' - 6"
Cylinders Lift	5" X 22"	5" X 22"
Cylinders Gate	6-1/2" X 22"	6.5" X 22"
Cylinders Push Off	5" X 40"	5" X 40"
Hydraulic Hoses	3,000 psi rated	3,000 psi rated
Hydraulics use a Sequencing Valve and requires 2 Tractor Remotes	2 Valve System	2 Valve System
Hydraulics Without Sequencing Valve	3 Valve System	3 Valve System
Hitches	Cast 360° Swivel	Cast 360° Swivel
Grease Locations	30 total	30 total
Safety Warning Lights	Standard LED	Standard LED
Hub & Spindle	10 Bolt 25,000 lbs.	10 Bolt 25,000 lbs.

Tire Inflation

Tire Size	Tire Manufacturer	Ply/Load Rating	Inflation Pressure (Psi) (Max.)
20.5 X 25	Titan or equivalent	20 Ply 20,900LBS. @ 5MPH	65 psi

Recommended Torque Specification For Lug Bolts and Nuts

Bolt Size	Torque (FT. LBS.)
7/8-14	450 ft. lbs.

General Torque Specifications (rev. 4/97)

TORQUE SPECIFIED IN FOOT POUNDS - This chart provides tightening torques for general purpose applications when special torques are not specified on process or drawing. Assembly torques apply to plated nuts and cap-screws assembled without supplemental lubrication (as received condition). They do not apply if special graphite moly-disulfide or other extreme pressure lubricants are used. When fasteners are dry (solvent cleaned) add 33% to as received condition torque. Bolt head identification marks indicate grade and may vary from manufacturer to manufacturer. Thick nuts must be used on grade 8 cap-screws. Use value in [] if using prevailing torque nuts.

UNC SIZE	SAE Grade 2	SAE Grade 5	SAE Grade 8	UNF SIZE	SAE Grade 2	SAE Grade 5	SAE Grade 8
1/4-20	4 [5]	6 [7]	9 [11]	1/4-28	5 [6]	7 [9]	10 [12]
5/16-18	8 [10]	13 [13]	18 [22]	5/16-24	9 [11]	14 [17]	20 [25]
3/8-16	15 [19]	23 [29]	35 [42]	3/8-24	17 [21]	25 [31]	35 [44]
7/16-14	24 [30]	35 [43]	55 [62]	7/16-20	27 [34]	40 [50]	60 [75]
1/2-13	35 [43]	55 [62]	80 [100]	1/2-20	40 [50]	65 [81]	90 [112]
9/16-12	55 [62]	80 [100]	110 [137]	9/16-18	60 [75]	90 [112]	130 [162]
5/8-11	75 [94]	110 [137]	170 [212]	5/8-18	85 [106]	130 [162]	180 [225]
3/4-10	130 [162]	200 [250]	280 [350]	3/4-16	150 [188]	220 [275]	320 [400]
7/8-9	125 [156]	320 [400]	460 [575]	7/8-14	140 [175]	360 [450]	500 [625]
1-8	190 [237]	408 [506]	680 [850]	1-14	210 [263]	540 [675]	760 [950]
1-1/8-7	270 [337]	600 [750]	960 [1200]	1-1/8-12	300 [375]	660 [825]	1080 [1350]
1-1/4-7	380 [475]	840 [1050]	1426 [1782]	1-1/4-12	420 [525]	920 [1150]	1500 [1875]
1-3/8-6	490 [612]	1010 [1375]	1780 [2225]	1-3/8-12	560 [700]	1260 [1575]	2010 [2512]
1-1/2-6	650 [812]	1460 [1825]	2360 [2950]	1-1/2-12	730 [912]	1640 [2050]	2660 [3325]
1-3/4-5	736 [920]	1651 [2063]	2678 [3347]	1-3/4-12	920 [1150]	2063 [2579]	3347 [4183]

METRIC:
Coarse thread metric class 10.9 fasteners and class 10.0 nuts and through hardened flat washers, phosphate coated, Rockwell "C" 38-45. Use value in [] if using prevailing torque nuts.

Nominal thread diameter (mm)	Newton Meters (Standard Torque)	Foot Pounds (Standard Torque)	Nominal Thread Diameter (mm)	Newton Meters (Standard Torque)	Foot Pounds (Standard Torque)
6	10 [14]	7 [10]	20	385 [450]	290 [335]
7	16 [22]	12 [16]	24	670 [775]	500 [625]
8	23 [32]	17 [24]	27	980 [1105]	730 [825]
10	46 [60]	34 [47]	30	1330 [1470]	990 [1090]
12	80 [125]	60 [75]	33	1790 [1950]	1340 [1450]
14	125 [155]	90 [115]	36	2325 [2515]	1730 [1870]
16	200 [240]	150 [180]	39	3010 [3210]	2240 [2380]
18	275 [330]	205 [245]	-----	-----	-----

Table 3-1: General Torque Specifications

Hydraulic Fitting Torque Specifications

TORQUE IS SPECIFIED IN FOOT POUNDS- 37° JIC, ORS, & ORB (REV. 10/97)

This chart provides tightening torques for general purpose applications when special torques are not specified on process or drawing. Assembly torques apply to plated nuts and capscrews assembled without supplemental lubrication (as received condition). They do not apply if special graphite moly-disulfide or other extreme pressure lubricants are used. When fasteners are dry (solvent cleaned) add 33% to as received condition torque. Bolt head identification marks indicate grade and may vary from manufacturer to manufacturer. Thick nuts must be used on grade 8 capscrews. Use value in [] if using prevailing torque nuts.

Parker Brand Fittings			
Dash Size	37 Degree JIC	O-Ring (ORS)	O-Ring Boss (ORB)
-4	11-13	15-17	13-15
-5	14-16	-----	21-23
-6	20-22	34-36	25-29
-8	43-47	58-62	40-44
-10	55-65	100-110	58-62
-12	80-90	134-146	75-85
-16	115-125	202-218	109-121
-20	160-180	248-272	213-237
-24	185-215	303-327	238-262
-32	250-290	-----	310-340
Gates Brand Fittings			
Dash Size	37 Degree JIC	O-Ring (ORS)	O-Ring Boss (ORB)
-4	10-11	10-12	14-16
-5	13-15	-----	-----
-6	17-19	18-20	24-26
-8	34-38	32-40	37-44
-10	50-56	46-56	50-60
-12	70-78	65-80	75-83
-14	-----	65-80	-----
-16	94-104	92-105	111-125
-20	124-138	125-140	133-152
-24	156-173	150-180	156-184
-32	219-243	-----	-----
Aeroquip Brand Fittings			
Dash Size	37 Degree JIC	O-Ring (ORS)	O-Ring Boss (ORB)
-4	11-12	10-12	14-16
-5	15-16	-----	16-20
-6	18-20	18-20	24-26
-8	38-42	32-35	50-60
-10	57-62	46-50	75-80
-12	79-87	65-70	125-135
-14	-----	-----	160-180
-16	108-113	92-100	200-220
-20	127-133	125-140	210-280
-24	158-167	150-165	270-360
-32	245-258	-----	-----

Table 3-2: Hydraulic Fitting Torque Specifications

Scheduled Maintenance

A quality high temperature grease should be used when lubricating the machine. Most areas of lube are scheduled daily, (8 to 10 hours of running). There are 27 grease zerks on the C, D, and E Models, that should be greased daily. There are also 2 zerks per axle, that should be greased weekly, with 3 pumps of grease. Reference to their location is listed in the Grease Guide, at the front of this book.

All bolts are torqued at the factory during assembly. After 24 hours of running, the Dealer service should recheck the torque on the hitch, wheel, axle, and pin retaining bolts. Each time the machine is greased, the operator or maintenance should look at these areas and the bolts involved to be sure none are working loose. After each 1000 hours of operation with the machine, the hitch, wheel, axle, and pin retaining bolts should be retorqued per the torque value chart in this manual. The axle jam nuts should be adjusted to a snug fit, seating the seal and bearings, then back the jam nut off one-fourth of a turn and lock in place.

For safety, identification, and general information, all missing or damaged decals on the machine should be replaced.

The ICON earthmovers have the interior of the bowl painted with a carbon base graphite paint, which rejects dirt. Should that paint wear off over a period of time, replacement paint may be ordered by the gallon through the original Dealer.

The cutting bits for the earthmover are available through ICON. The bevel is reversed as compared to the normal bits, in order to make loading easier in tough ground. The reverse bevel will not have the same longevity in wear as the normal bevel. Replacement bits may be ordered from ICON, or your Dealer, Refer to the cutting edge section of this manual for size and part number.

All retaining pins have replaceable bushings. Watch the pin locations in action to review for loose and worn operation.

Remember, the longevity of your machine will depend on proper operation and maintenance.

Warning!

To prevent a hazardous situation, which if not avoided can result in injury or death, read and follow these instructions!

- Read and understand the operator's manual before operating the machine. Allow no one to operate the machine before reading the manual and being instructed on the proper operation.
- Before servicing the machine, block the wheels, shut the tractor off, set the brakes, and remove the key. If working under the machine, block the machine up for a safe and secure working area. Apply any safety stops provided.
- When working with hydraulic lines, cylinders, or fittings, wear protective clothing and safety glasses to guard against high pressure oil leaks.
- Do not allow anyone on, or near the machine while it is running or in motion.
- Do not operate the machine on a steep incline or slope that could create an imbalance or rollover.

Product Information

Daily Walk-Around Inspection

The majority of the grease zerks are marked with a Grease Daily decal. These should be attended to on a daily basis.

The remainder of the zerks (such as the axles) are marked Grease Weekly. These should be given attention every week or app. 40 hrs. of run time. Usually these require 3 pumps of grease—each week.

If the conditions are extreme (muddy, sandy etc.) the lubrication may need to be checked more often.

Hoses, lines and fittings should be visually checked daily for leaks, bends and chaffing.

Tires should be checked daily for low air pressure and cracks or damage to the tread or sidewalls.

Inspect the inner and outer seals in the rear axles. Insure that they are seated properly and roll pinned in place. Should it appear that there is a need to tighten the axle bearings, refer to the tightening procedure in the service section.

All grease zerks are located for accessibility from the outside of the machine. However, if it becomes necessary to crawl in or under the machine, be certain to lock all cylinder stops in place before attempting to do so. Also, shut off the pulling units engine, remove the key and set the parking brake.

ICON Earthmover Grease Daily Guide

Axles should be greased weekly (4 zerks)

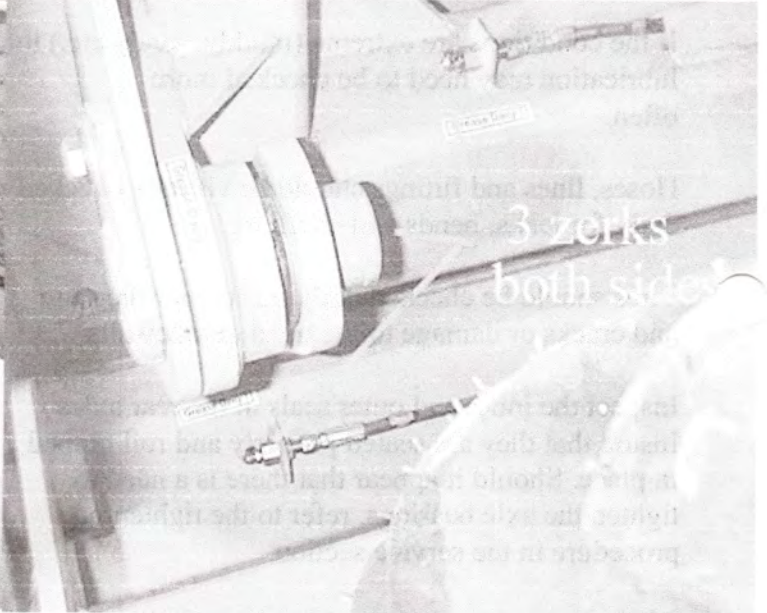
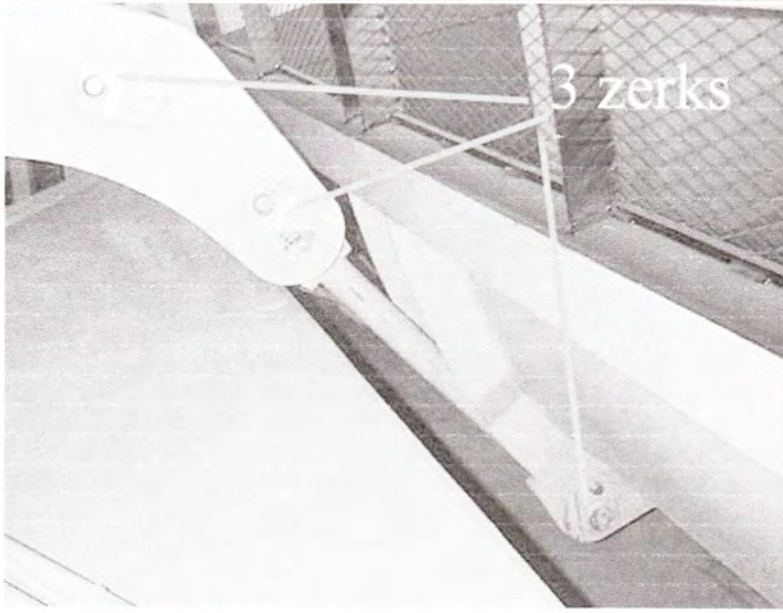
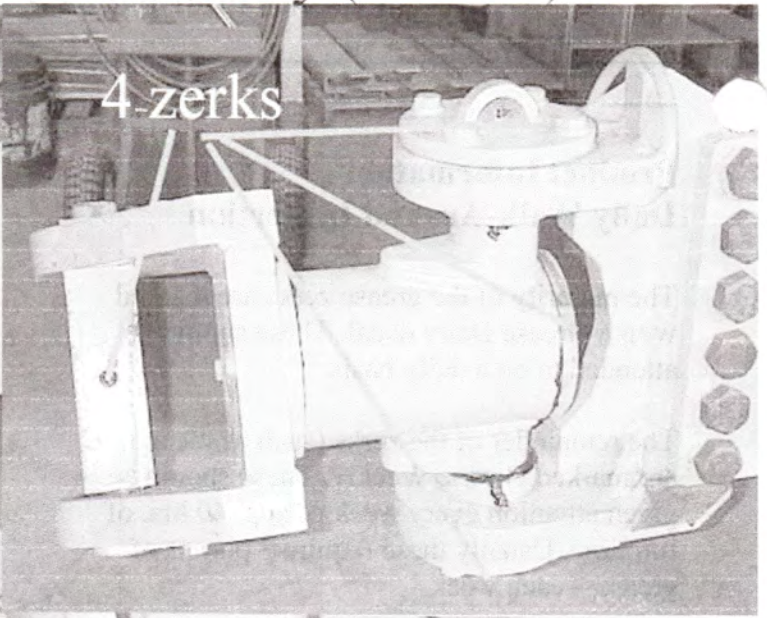

Located thru the hole in the side panel is the clam pivot zerk, on each side

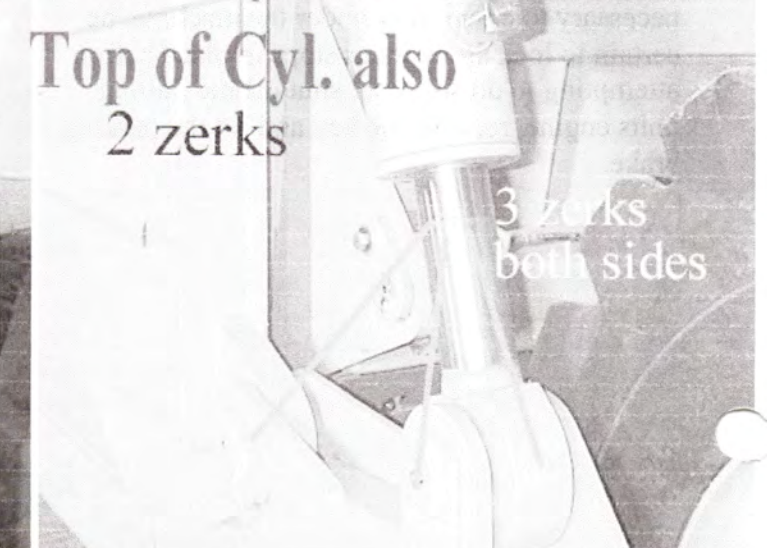

Mounting/Dismounting of Earthmover

The ICON Earthmover features a one person quick attach system, for easy mount/dismount of the power unit.

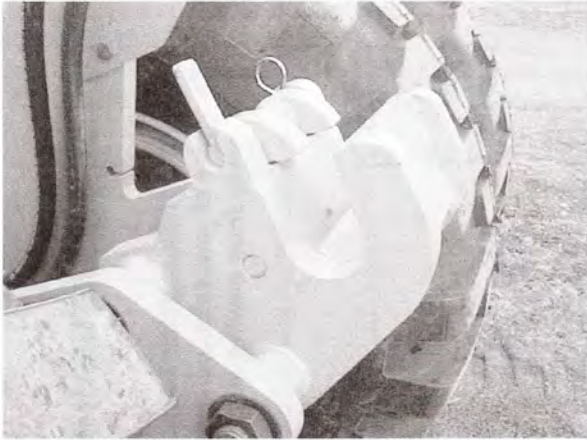

Back the power unit close enough to connect hydraulic hoses.

Below is the current hyd. configuration used on the MT Series.
NOTE: The covers are marked with a + or -, the hoses on the ICON scraper will also carry these markings, along with valve number designations. This is the recommended hook up, but should be left up to the operator's preference.

NOTE: High Pressure fluid can cause serious damage to eyes and hands. See Safety Section for safe hookup procedure.

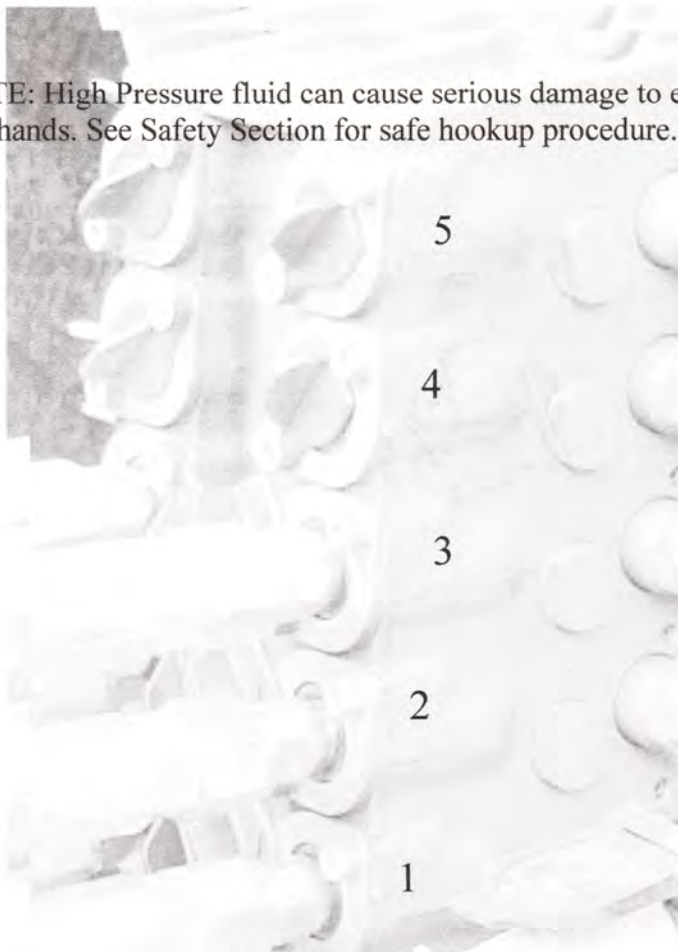

Hydraulic Hook Up

Once the Power unit is in position, the hydraulic hoses should be attached. The Valve 1 banded hoses should be placed in the #1 outlet. (Raise/Lower)

Valve 2 banded hoses should be in #2 outlet (Gate/Wall)

If there is a tandem unit, the Valve 3 is (Gate/Wall) and the Valve 4 (Raise/Lower) for the tandem machine.

Mounting Procedures .

Note: As with any moving part, the potential for injury is present. Be aware of your surroundings while backing. Make certain that no one is located between the tractor and the machine. Keep hands, feet, and all body parts away from any machine component that pivots, swings, or moves in any way, to avoid a potential injury.

- * Using the hydraulics, lower the machine this will lift the hitch, allowing the tractor to be backed into position.
- * Position the hitch to allow the adapter to slide into the cradle on the hitch. Raise the machine, using the hydraulics, this will lower the swivel hitch into the quick attach cradle.
- * Once the adapter is fully seated into the cradle, pivot the lock down ears over the adapter and insert the lock down pin and snap pin.
- * **To dismount unit, reverse steps.**

Mounting/Dismounting of Earthmover

WARNING: Although the ICON hitch is designed for safety during earthmover mounting/dismounting. Be aware of your surroundings, and of other persons. During mount/dismount, keep all body parts away from moving machine components.

Step 1

Back the pulling unit close enough to the hitch to allow hookup of the hydraulic hose lines.

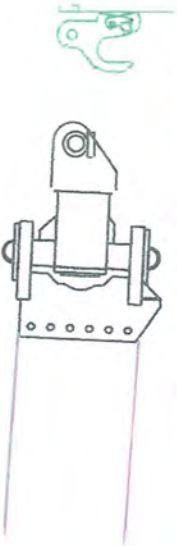

Step 4

With the machine raised to proper height, the lockdown ears and the adapter in the proper locations, back the tractor under the swivel hitch.

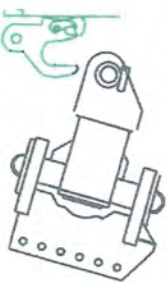

Step 2

Shown is the typical hydraulics on the MT 800. However, some are positioned differently. The hydraulic hoses are marked with valve numbers and either + or - to aid in hook up.

If the unit is a tandem valves 3 & 4 are used.

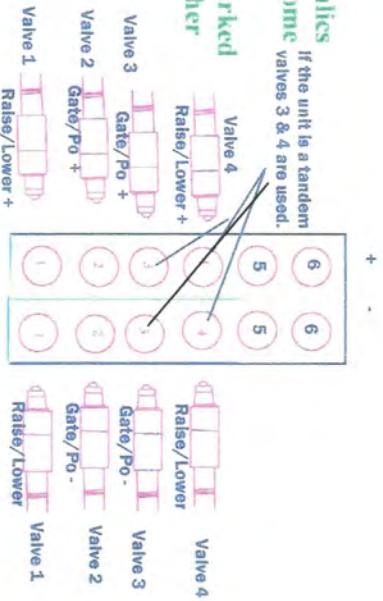

Step 5

It drastically raise the machine (using #1 lever) this will lower the swivel hitch adapter into the hitch cradle.

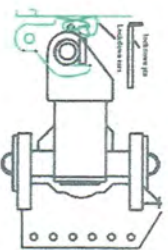

Step 3

After the hydraulics are hooked, lower the machine (using #1) this will raise the tongue of the earthmover. Raise the machine until the hitch will clear the cradle on the drawbar. Make certain that the swivel hitch adapter is turned with the flat to the top; this allows the adapter and hitch to slide into the cradle of the drawbar.

Pull the keeper, slide the lockdown pin out of the pivot ears and pivot the ears toward the front

Step 6

When the adapter is seated in the hitch cradle, pivot the lockdown ears over the adapter and insert the lockdown pin and keeper.

Connection is complete. To dismount the unit - reverse the procedure.

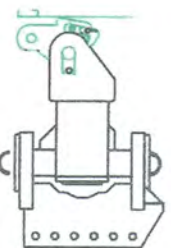
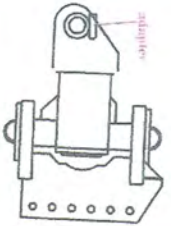

NOTE: On early models of the contractor hitch, a plate and 1" bolts were used to secure the swivel hitch adapter. Instead of the pivot ears and lockdown pin. The same procedure applies.

Operating Techniques

Each scraper operator has his/her own methods of hydraulic sequence and overall operation of the machine. The following are suggestions as to the ICON Earthmover. Personal methods and choice of tractors may alter these suggestions.

The ICON machine is completely assembled and checked at the factory. It is requested of the Dealer that after the first 24-36 hours of operation, the machine is then checked out and adjusted per the suggested list supplied by ICON.

The hydraulic hose configuration at the front of the machine is arranged to fit the late model remotes. Some tractors may require the relocation of the hydraulic hose configuration.

For ease of operation, a sequential configuration is needed. If the 3 valve system is ordered, the sequential order is first valve [Raise/Lower], (pull to raise/push to lower). Second valve [gate] (pull to raise/push to lower). Third valve is [ejection] (pull to eject/push to return wall). For rapid eject, the operator can pull both second & third valves in unison. Should the optional 2 valve system be ordered, the first valve (raises/lowers) the machine. The second valve (gate and wall eject). If the machines are ordered with the 3 valve, to be pulled in tandem with four remotes, a solenoid hydraulic option is installed at the factory. In this case, the fourth valve is (pull to raise and push to lower the rear machine). The tandem option includes a toggle switch for the cab. The toggle switch is available in a magnetic base box, or as a package to mount in a knock-out in the tractor instrument panel. Forward on the switch activates second and third levers for eject of the front machine, and reverse of the switch activates eject for the rear machine.

A visual depth gauge is located at the top rear of each machine to alert the operator as to the depth (above or below ground), of the cutting bit and the eject depth of the load.

The allowed tractor engine horsepower for each ICON model is noted on a decal at the top front of the machine hitch. On some loads the operator will notice some material spill over the front of the gate when closing on a load. The machine is designed to load the majority of the weight at the rear of the machine to take unnecessary down force away from the rear of the tractor. Any alterations to the design could result in problems.

ICON builds the Quick Attach Hitch for the tractor and the tandem hookups

(See Operation Section, page 6 for details).

The front gate and the ejection wall of the ICON are painted with a special dirt reject, graphite based paint. Should this finish wear off, the carbon base paint is available from ICON through your Dealer.

Transporting Techniques

All ICON Earthmovers are build under 12 feet wide, this eliminates the need for flag vehicles or any special permits, in most states.

Model C - Exploded View

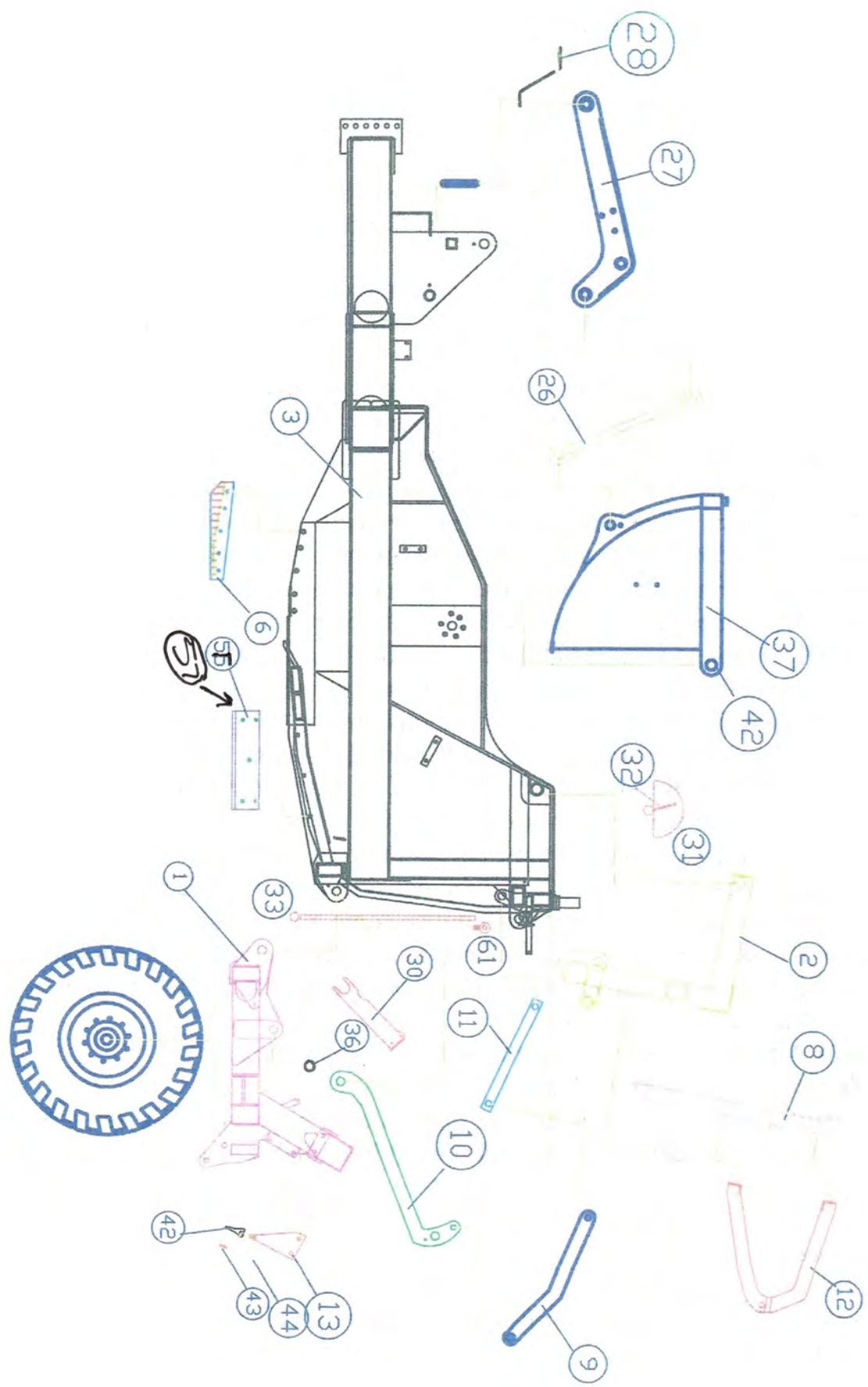

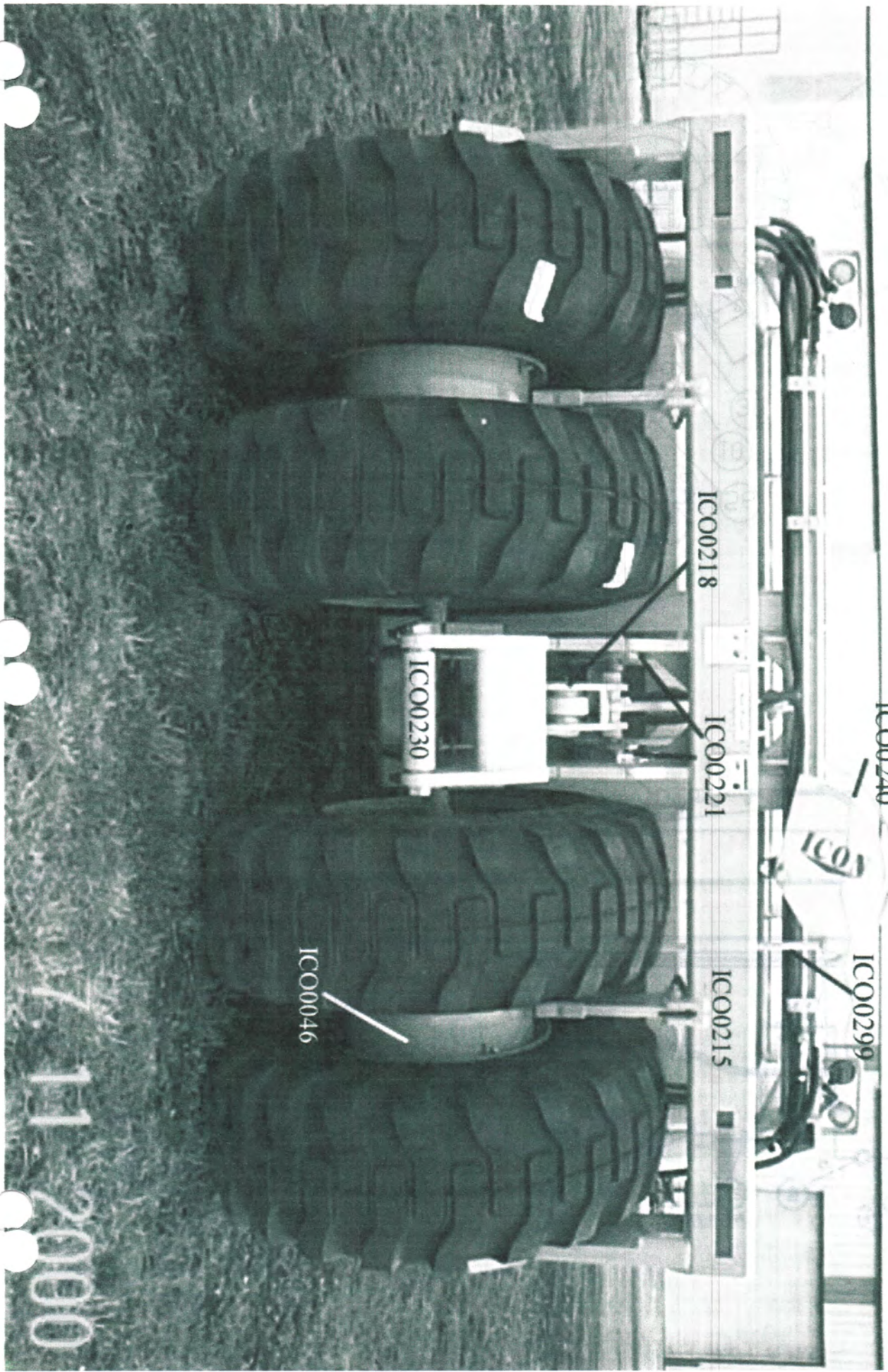

IC00240

IC00299

IC00218

IC00221

IC00215

IC00230

IC00046

11-2000

184025 - (2)
9300751 - (2)
9300469 - (2)
184031 - (1)
K00219 - (2)

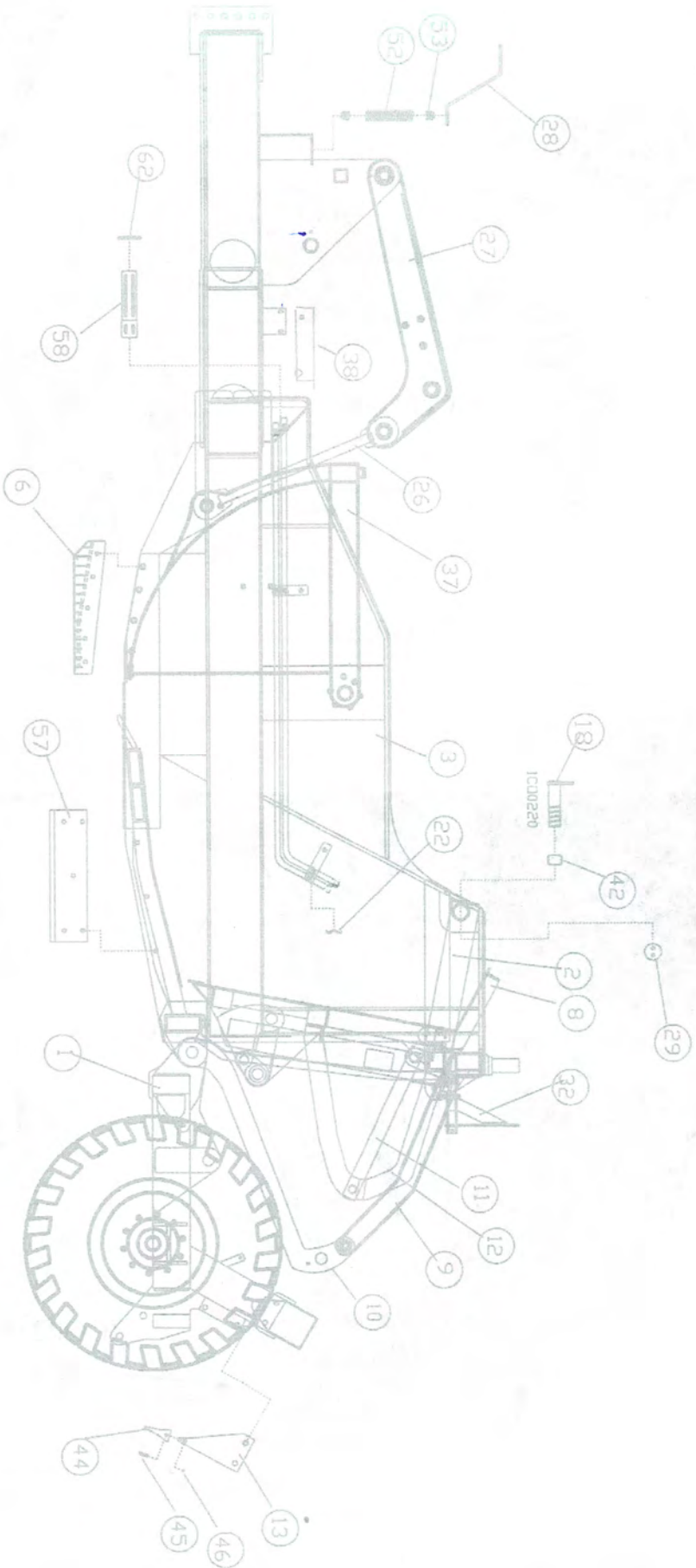

Mainframe - Assembled View

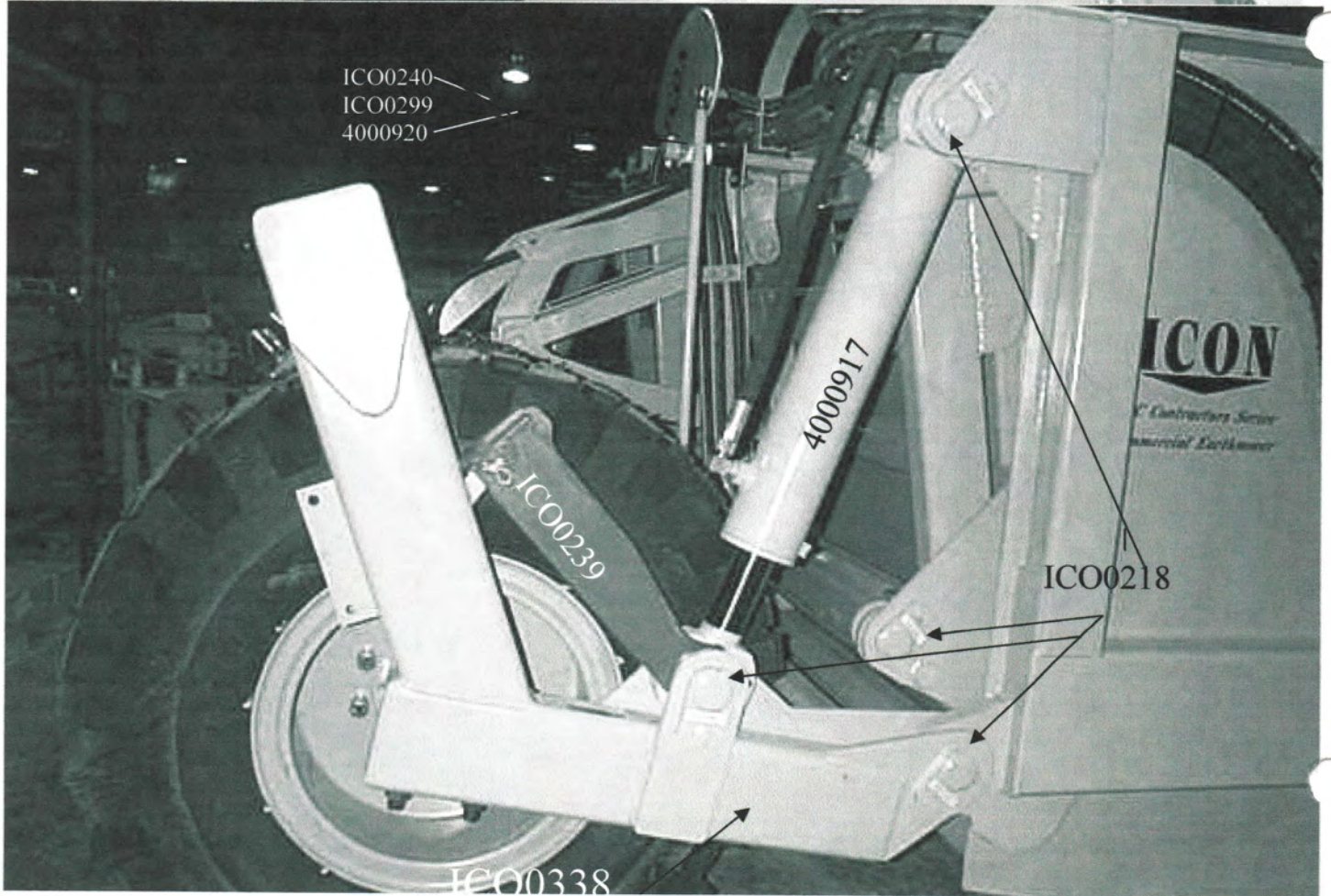
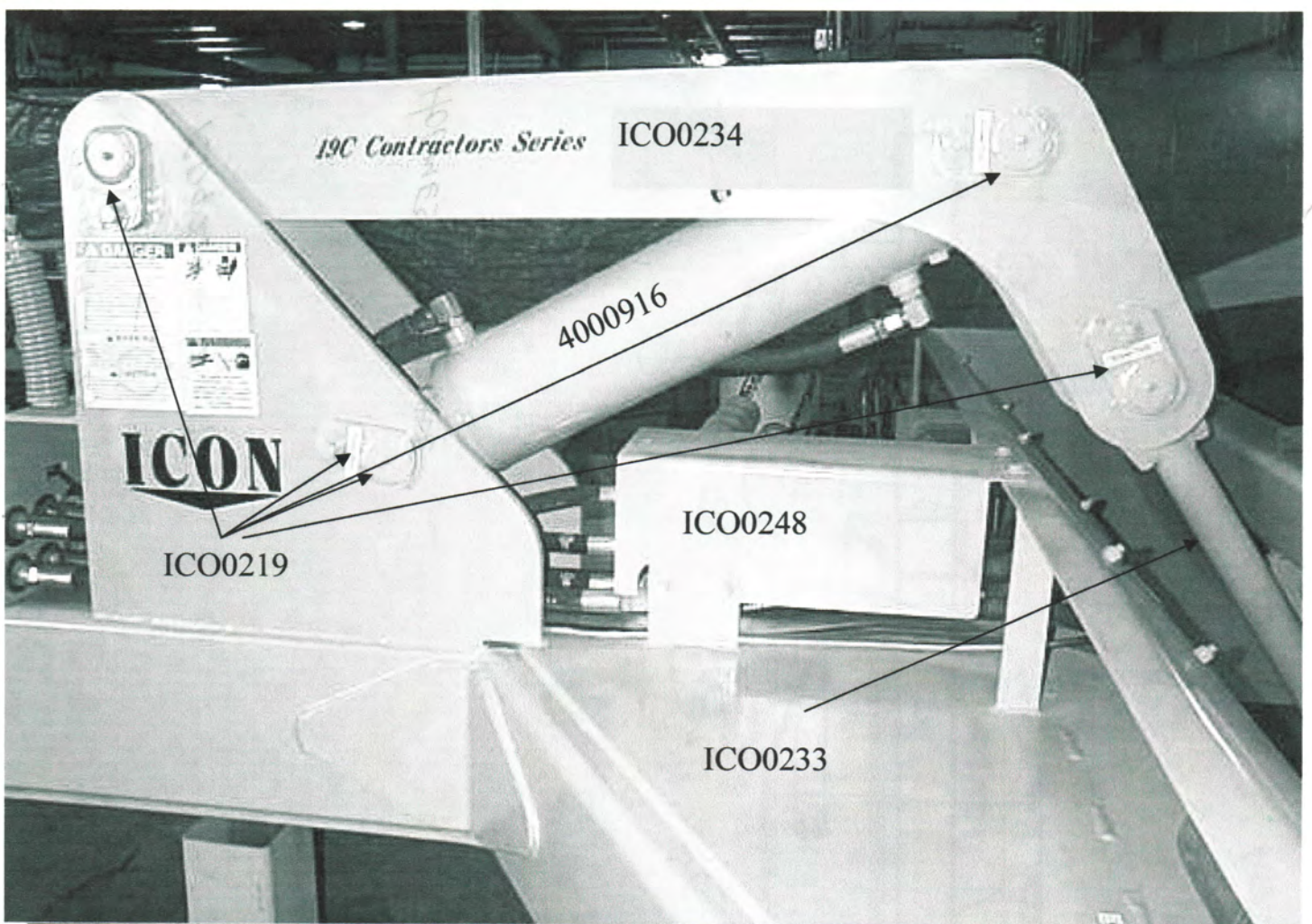

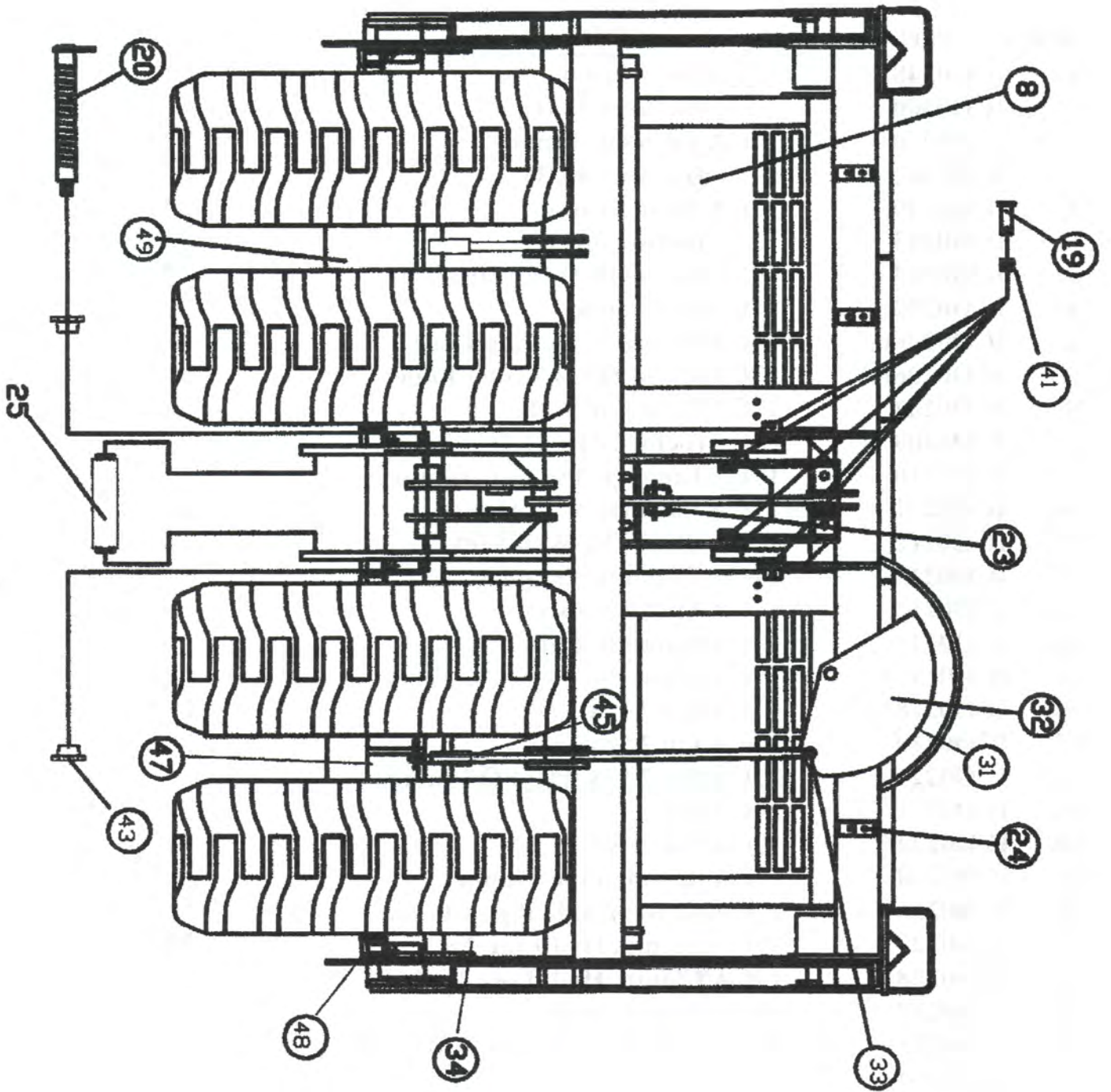

PARTS LIST
17CA (beginning with serial # 4531)

Ref#	Part #	Description	Qty
1.	ICO0348	17CA Rear Frame	1
	ICO0300	(before #4531)	
2.	ICO0260	17CA Push Off Frame	1
	ICO0302	(before #4531)	
3.	ICO0349	17CA Main Frame	1
	ICO0303	(before #4531)	
4.	ICO0304	17CA Push Off Wear Strip	2
5.	ICO0205	17CA Gate Spacer	2
6.	ICO0206L	17CA Left Side Cutting Edge	1
7.	ICO0206R	17CA Right Side Cutting Edge	1
8.	ICO0262	17CA Push Off Wall	1
	ICO0309	(before #4531)	
9.	ICO0210	17CA Linkage, PO Cyl. Mount	1
10.	ICO0211	17CA Push Off Cyl. Mount	1
11.	ICO0212	17CA Push Off Wall Linkage	2
12.	ICO0213	17CA Push Off Support	1
13.	ICO0215	17CA Mud Scrapers	2
14.	ICO0216	17CA Gate Pin Cap	2
15.	ICO0217	17CA Clam Pin	2
16.	ICO0218 ^{ICO1133}	17CA Pin 2 ½ x 5 ¾	12
17.	ICO0219	17CA Pin 2 ½ x 11 7/8	4
18.	ICO0220	17CA Pin 2 ½ x 9 ¼ PO Frame	2
19.	ICO0221	17CA Pin 1 ½ x 4 ¼	5
20.	ICO0222	17CA Pin 2 ½ x 18 5/8	1
21.	ICO0224	17CA #2 Side Pipe Clamp	6
22.	ICO0226	17CA #2 Rear Side Pipe Clamp	4
23.	ICO0227	17CA Clamp, Hyd Line 2 x 2 ¾	2
24.	ICO0228	17CA Clamp, Hyd. Line 2 x 5 ¼	4
25.	ICO0230	17CA Rear Tow Bar	1
26.	ICO0233	17CA Gate Link	1
27.	ICO0234	17CA Gate Arm	1
28.	ICO0235	17CA Hose Support	1
29.	ICO0236	17CA Push Off Pin Cap	2
30.	ICO0239	17CA Rear Cyl. Stop	2
31.	ICO0240	17CA Depth Gauge	1
32.	ICO0241	17CA Depth Gauge Indicator	1

17CA Parts List

33.	ICO0299	17CA Depth Gauge Link	1
	ICO0242	(before #4531)	
34.	ICO0243	17CA Grease Line Linkage	2
35.	ICO0244	17CA Spacer, Lift Cyl – Rear Frame	4
36.	ICO0249	17CA Depth Gauge Retainer	1
37.	ICO0347	17CA Gate	1
	ICO0301	(before #4531)	
38.	ICO0248	17CA Hyd. Shield	1
39.	ICO0257	17CA Hyd. Line Clamp 2 x 3 ½	4
40.	ICO0258	17CA Push Off Bearing	1
41.	4000406	Bushing, 175150150	4
42.	4000902	Bushing, 300251200	20
43.	4000914	Bushing, OD 2.5/ ID SF STL 2.5	2
44.	4000877	Tip, Packer Cleaner Bar	2
45.	4000878	Pin, Packer Cleaner Tip	2
46.	4000879	Pin, Packer Tip Retainer	2
47.	2000212	17CA Hub Assembly	2
48.	SCR 2037	17CA Axle Clamp	8
49.	ICO0231	17CA Rim, Mud Bands	2
50.	4000942	Rim, 14 x 25 17.5 x 25T 13.188BC ✓	2
50a.	ICO0322	Rim, 14 x 25 3 pc ✓	2
51.	4000635	Tire, 17.5 x 25 - 16 ply	4
52.	4000918	Spring, Hose Holder 9"	2
53.	4000919	Spring, Hose Holder Plug	4
54.	4000916	Hyd. Cylinder 6 ½ x 22 (36 ¼)	1
55.	4000917	Hyd, Cylinder 5 x 22 (37 ¼)	2
56.	4000907	Hyd. Cylinder 5 x 40 (53 ¾)	1
57.	4000922	17CA Cutting Edge – Rear Bevel	2
58.	4000419	Welding Tube	1
59.	4000054	Oil, Hydraulic HTB	13
60.	4000903	Bearing, Spherical	4
61.	4000920	Ball Joint, Rod End	2
62.	4000926	Clamp, Hose 7"	1
63.	4000927	Bearing, Snap Ring	4

PARTS LIST
CE - 19CA (Beginning with serial # 4041)

Ref #	Part #	Description	Qty
1.	ICO0338	19CA Rear Frame	1
	ICO0200	(before #4041)	
2.	ICO0259	19CA Push Off Frame	1
	ICO0202	(before #4041)	
3.	ICO0339	19CA Main Frame	1
	ICO0203	(before #4041)	
4.	ICO0204	19CA Push Off Wear Strip	2
5.	ICO0205	19CA Gate Spacer	2
6.	ICO0206L	19CA Left Side Cutting Edge	1
7.	ICO0206R	19CA Right Side Cutting Edge	1
8.	ICO0261	19CA Push Off Wall	1
	ICO0209	(before #4041)	
9.	ICO0210	19CA Linkage, PO Cyl. Mount	2
10.	ICO0341	19CA Push Off Cyl. Mount	1
	ICO0211	(before # 4041)	
11.	ICO0212	19CA Push Off Wall Linkage	2
12.	ICO0213	19CA Push Off Support	1
13.	ICO0215	19CA Mid Mud Scraper	2
14.	ICO0216	19CA Gate Pin Cap	2
15.	ICO0217	19CA Clam Pin	2
16. <i>IC01193</i>	ICO0218	19CA Pin 2 ½ x 5 ¾	12
17.	ICO0219	19CA Pin 2 ½ x 11 7/8	4
18.	ICO0220	19CA Pin 2 ½ x 9 ¼	2
19.	ICO0221	19CA Pin 1 ½ x 4 ¼	5
20.	ICO0222	19CA Pin 2 ½ x 18 5/8	1
21.	ICO0224	19CA #2 Side Pipe Clamp	6
22.	ICO0226	19CA #2 Rear Side Pipe Clamp	4
23.	ICO0227	19CA Clamp, Hyd. Line 2 x 2 ¾	2
24.	ICO0228	19CA Clamp, Hyd. Line 2 x 5 ¼	4
25.	ICO0230	19CA Rear Tow Bar	1
26.	ICO0233	19CA Gate Link	1
27.	ICO0234	19CA Gate Arm	1
28.	ICO0235	19CA Hose Support	1
29.	ICO0236	19CA Push Off Pin Cap	2
30.	ICO0239	19CA Rear Cyl. Stop	2

Parts List - 19CA

31.	ICO0240	19CA Depth Gauge	1
32.	ICO0241	19CA Depth Gauge Indicator	1
33.	ICO0299	19CA Depth Gauge Link	1
	ICO0242	(before # 4041)	
34.	ICO0243	19CA Grease Line Linkage	2
35.	ICO0244	19CA Spacer, Lift Cyl. - RF	4
36.	ICO0249	19CA Depth Gauge Retainer	1
37.	ICO0298	19CA Gate	1
	ICO0250	(before # 4041)	
38.	ICO0248	19CA Hyd. Shield	1
39.	ICO0257	19CA Hyd. Line Clamp 2 x 3 ½	4
40.	ICO0258	19CA Push Off Bearing	1
41.	4000406	Bushing, 175150150	4
42.	4000902	Bushing, 300251200	20
43.	4000914	Bushing, OD 2.5/ ID SF STL 2.5	2
44.	4000877	Tip, Packer Cleaner Bar	2
45.	4000878	Pin, Packer Cleaner Tip	2
46.	4000879	Pin, Packer Tip Retainer	2
47.	2000040	19CA Hub Assembly	2
48.	SCR2037	19CA Axle Clamp	8
49.	ICO0046	Rim, Mud Bands	2
50.	ICO0022	Rim, 17 x 25 3 pc.	4
51.	4000636	Tire, 20.5 x 25 16 ply	4
52.	4000918	Spring, Hose Holder 10"	2
53.	4000919	Spring, Hose Holder Plug	4
54.	4000916	Hyd. Cylinder 6 ½ x 22 (36 ¼)	1
55.	4000917	Hyd. Cylinder 5 x 22 (37 ¼)	2
56.	4000907	Hyd. Cylinder 5 x 40 (53 ¾)	1
57.	4000922	19CA Cutting Edge - Rear Bevel	2
58.	4000419	Welding Tube	1
59.	4000054	Oil, Hydraulic HTB	13
60.	4000903	Bearing, Spherical	4
61.	4000920	Ball Joint, Rod End	2
62.	4000926	Clamp, Hose 7"	1
63.	4000927	Bearing, Snap Ring	4

Bolt List For 17 & 19 CA Models

Part #	Description	Qty	Ref #	Part #	Description	Qty	Ref#
<u>Cutting Edges/Frost Bits</u>				<u>Side Cutting Edges</u>			
BP	Plow Bolt, 1 x 2 1/2 gr 8	22		BP	Plow Bolt, 3/4 x 2 1/2 gr 8	10	6 & 7
WFH	Washer, Flat, Hard 1"	22		WFH	Washer, Flat, Hard 3/4"	10	
NJ	Nut, Jam 1"	22		NJ	Nut, Jam 3/4"	10	
<u>Mud Bands</u>				<u>Rear Mud Scrapers</u>			
BH	Bolt, Hex 1/2 x 1 1/2" gr 8	4	49	BH	Bolt, Hex 1 x 4 1/2" gr 8	4	13
WF	Washer, Flat 1/2"	4		WFH	Washer, Flat, Hard 1"	4	
NL	Nut, Nyloc 1/2" gr 2	4		NH	Nut, Hex 1" gr 8	4	
<u>Front Hose Support</u>				<u>Clam Pins</u>			
5000616	Hose Clamp, Plastic	6	26	BH	Bolt, Hex 3/4 x 2 1/2" gr 8	12	15
5000618	Hose Clamp Cover Plate	4		WFH	Washer, Flat, Hard 3/4"	12	
BH	Bolt Hex, 3/8 x 5" gr 8	4		NH	Nut, Hex 3/4" gr 8	12	
NW	Nut, Whiz 3/8"	8		BH	Bolt, Hex 5/8 x 1 1/2" gr 8	4	
BH	Bolt, Hex 3/8 x 3" gr 5	4		WFH	Washer, Flat, Hard 5/8"	4	
				ICO0205	Gate Spacer	2	
<u>Front/Side Hyd. Clamps</u>				<u>Push Off Cyl Mount</u>			
BH	Bolt, Hex 1/2 x 2 1/2" gr 5	8	21&22	BH	Bolt, Hex 1 1/2 x 7" gr 8	1	9&10
WFH	Washer, Flat, Hard 1/2"	8		WFH	Washer, Flat, Hard 1 1/2"	1	
NL	Nut, Nyloc 1/2"	8		NH	Nut, Hex 1 1/2" gr 8	1	
<u>Push Off Support To Wall</u>				<u>Push Off Wall Wear Strip</u>			
BH	Bolt, Hex 1 x 6" gr 8	4	12	BC	Bolt, Carriage 1/2 x 1 1/2"	12	4
NL	Nut, Nyloc 1" gr 5	4		WFH	Washer, Flat, Hard 1/2"	12	
WF	Washer, Flat 1" IDx2 1/2" OD	4		NH	Nut, Hex 1/2" gr 5	12	
<u>Swivel Hitch Bracket</u>				<u>Swivel Hitch Caps</u>			
BH	Bolt, Hex 1 1/4 x 6" gr 8	6	see	BH	Bolt, Hex 3/4 x 3" gr 8	8	see
WFH	Washer, Flat, Hard 1 1/2"	6	swivel	WFH	Washer, Flat, Hard 3/4"	16	swivel
NH	Nut, Hex 1 1/2" gr 8	6	hitch				hitch
<u>Rear Cutting Edges</u>				<u>Rear Tow Bar</u>			
BP	Bolt, Plow 3/4 x 3" gr 8	6	57	BH	Bolt, Hex 1 1/2 x 3" gr 8	2	25
WFH	Washer, Flat, Hard 3/4"	6		WFH	Washer, Flat, Hard 1 1/2"	2	
NJ	Nut, Jam 3/4" gr 8	6					
<u>Axle Clamp Bolts</u>				<u>Hose Holder Spring</u>			
BH	Bolt, Hex 1 x 9" gr 8	8	48	BH	Bolt, Hex 1/2 x 1" gr 5	4	52
WFH	Washer, Flat, Hard 1"	8		WF	Washer, Flat 1/2"	4	
NH	Nut, Hex, 1" gr 8	8		WFH	Washer, Flat, Hard 1/2"	4	
<u>Retainers For 1 1/2" Pins</u>				<u>Wheel Bolts</u>			
BH	Bolt, Hex 1/2 x 3" gr 5	5	see	SCR	Spacer SCR2078	40	50
NL	Nut, Nyloc 1/2" gr 2	5	service Page	BH	Bolt, Hex 7/8 x 3" fine gr 8	40	
<u>Swivel Hitch Pin (ico0123)</u>				<u>Retainer For 2 1/2" Pins (except ico0122)</u>			
BH	Bolt, Hex 5/8 x 1 1/2" gr 8	2	see	BH	Bolt, Hex 5/8 x 1 1/2" gr 8	15	16&17
WF	Washer, Flat 5/8"	1	swivel	BH	Bolt, Hex 5/8 x 1 3/4" gr 8	3	
WFH	Washer, Flat, Hard 5/8"	2	hitch	WF	Washer, Flat 5/8"	18	
ICO	Spacer 9/16" (ico0090)	1		WFH	Washer, Flat, Hard 5/8"	18	
				ICO	Spacer 9/16" (ico0090)	15	
				ICO	Spacer 3/4" (ico0343)	3	
<u>Push Off Frame - Pin Caps</u>				<u>Front Hyd Coupler Plate</u>			
BH	Bolt, Hex 5/8 x 1 1/2" gr 8	4	14	Ring	O-Ring 1 3/4-1 1/2 2-222	6	see hyd page
WFH	Washer, Flat, Hard 5/8"	4		WFH	Washer, Flat, Hard 1 1/4"	10	
<u>Main Frame Spacers</u>				<u>Rear Cyl. Stops</u>			
WM	Washer, Machine 2.5x3.5	8	2	4000923	Pin, Clevis 1/2 x 4 1/2"	2	30
				BP	Bridge Pin 7/32"	2	

Bolt List For 17 & 19 CA Models

Part #	Description	Qty	Ref #	Part #	Description	Qty	Ref #
Gate Cyl. Stop				Hyd. Shield Cover (front)			
WFH	Washer, Flat, Hard 1"	1		WF	Washer, Flat 1/2"	4	38
BH	Bolt, Hex 1 x 11" gr 8	1		BH	Bolt, Hex 1/2 x 1" gr 5	2	
NL	Nut, Nyloc 1" gr 5	1		NW	Nut, Whiz 1/2"	3	
.KL	Pin, Klik 5/16 x 2 11/16"	1		BH	Bolt, Hex 1/2 x 10" gr 5	1	
Depth Gauge Assy.				Retainer For ico0222 (center rear frame pin)			
BH	Bolt, Hex 1/2 x 3" gr 5	1	31	BH	Bolt, Hex 5/8 x 2 1/2" gr 8	1	20
NL	Nut, Nyloc 1/2" gr 2	2		WF	Washer, Flat 5/8"	1	
BH	Bolt, Hex 3/4 x 3" gr 8	2		WFH	Washer, Flat, Hard 5/8"	1	
ICO	ICO0305 Spacer	2		ICO	Pin Spacer ICO0090	2	
WFH	Washer, Flat, Hard 3/4"	2		NH	Nut, Hex 1 1/2" gr 8	1	
NL	Nut, Nyloc 3/4" gr 5	2		WF	Washer, Flat 1 1/2"	1	
BH	Bolt, Hex 1/2 x 2" gr 5	1		WFH	Washer, Flat, Hard 1 1/2"	1	
WF	Washer, Flat 1/2"	2					
WFH	Washer, Flat, Hard 1/2"	1					
NH	Nut, Hex 3/4" Jam Nut - Fine	1					
Hose Brackets (rear frame)				PO Linkage Hose Clamp			
BH	Bolt, Hex 1/2 x 2 1/2" gr 5	8		NL	Nut, Nyloc 1/2" gr 2	2	
Push Off Frame Spacer				Zerks			
WM	Washer, Machine 2.5 x 3.5"OD	4		5000306	FTG Coupling 1/8"	2	
				4000067	Zerk, Straight 1/8"	13	
				4000591	Zerk, 1/8" 90deg.	17	
				4000720	Adaptor 1/8 - 27-1/8NPT 90elb	6	
				4000552	Zerk, 45 deg 1/8"	1	
Bolts for Quick Attach Tandem Hitch							
ICO0267	1 1/2" bolts/washer/jam nut	2	see hitch sec.				

Rear Frame Model C

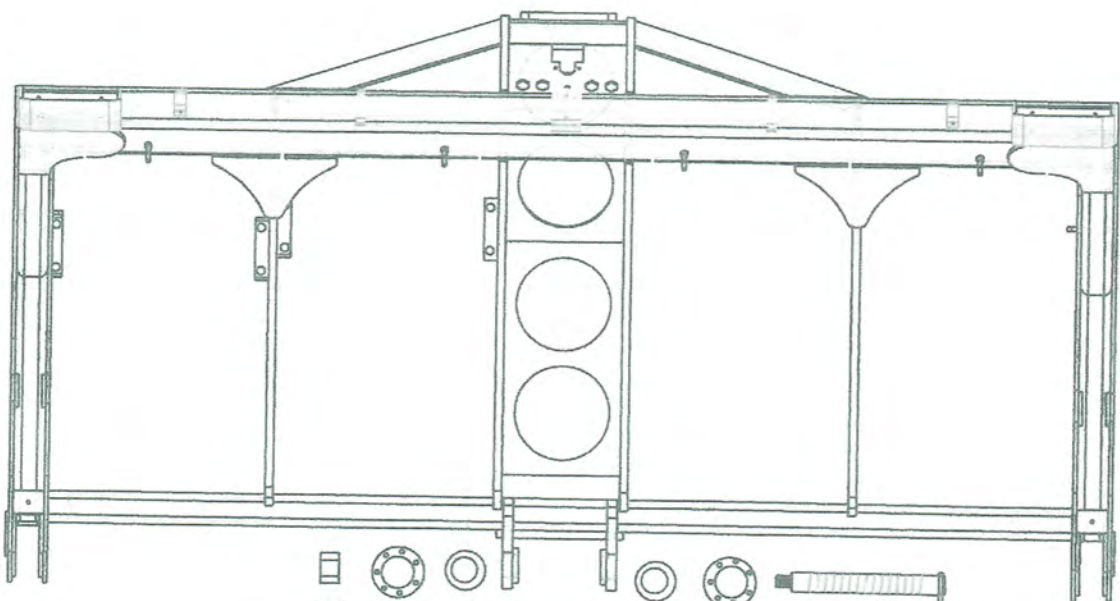
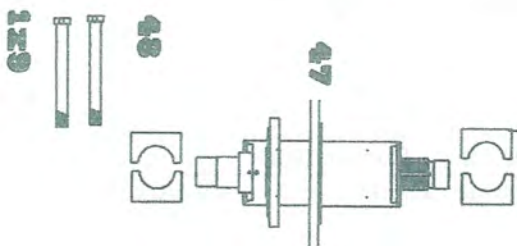
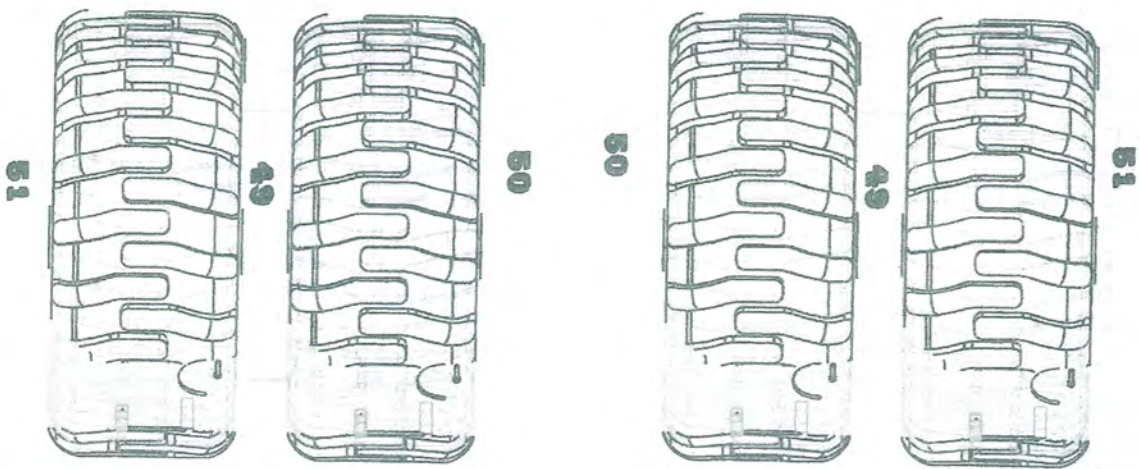

IC00338 (19C)

IC00348

Main Frame Model C

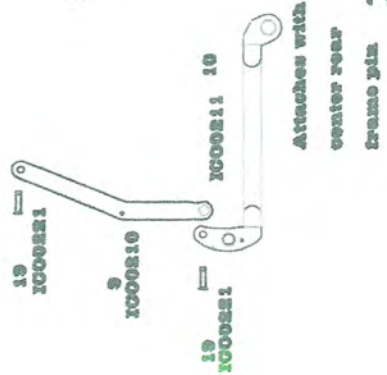
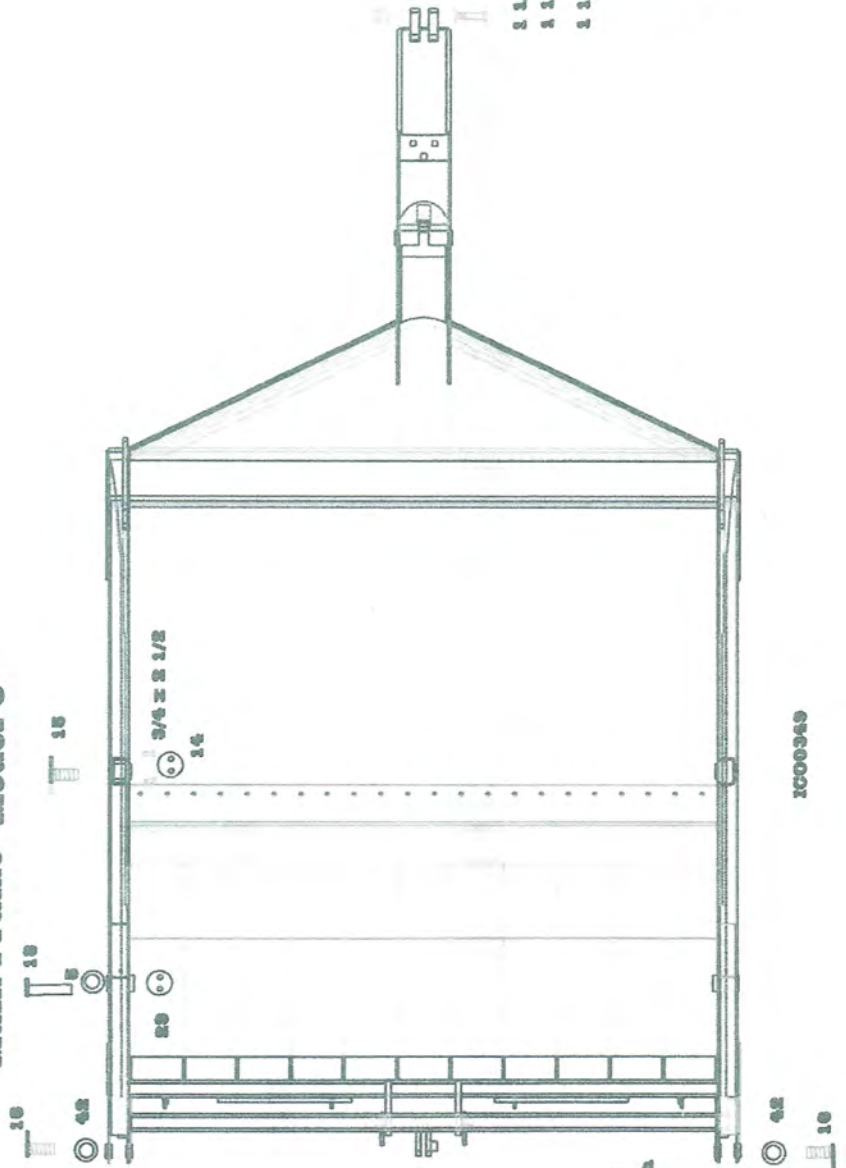

- 1 1/2 x 6
- 1 1/2 Hex nut
- 1 1/2 Hard washers

Note: Every other bolt should alternate direction to aid in shear strength.

1000349

Push Off Wall and Frame Model C

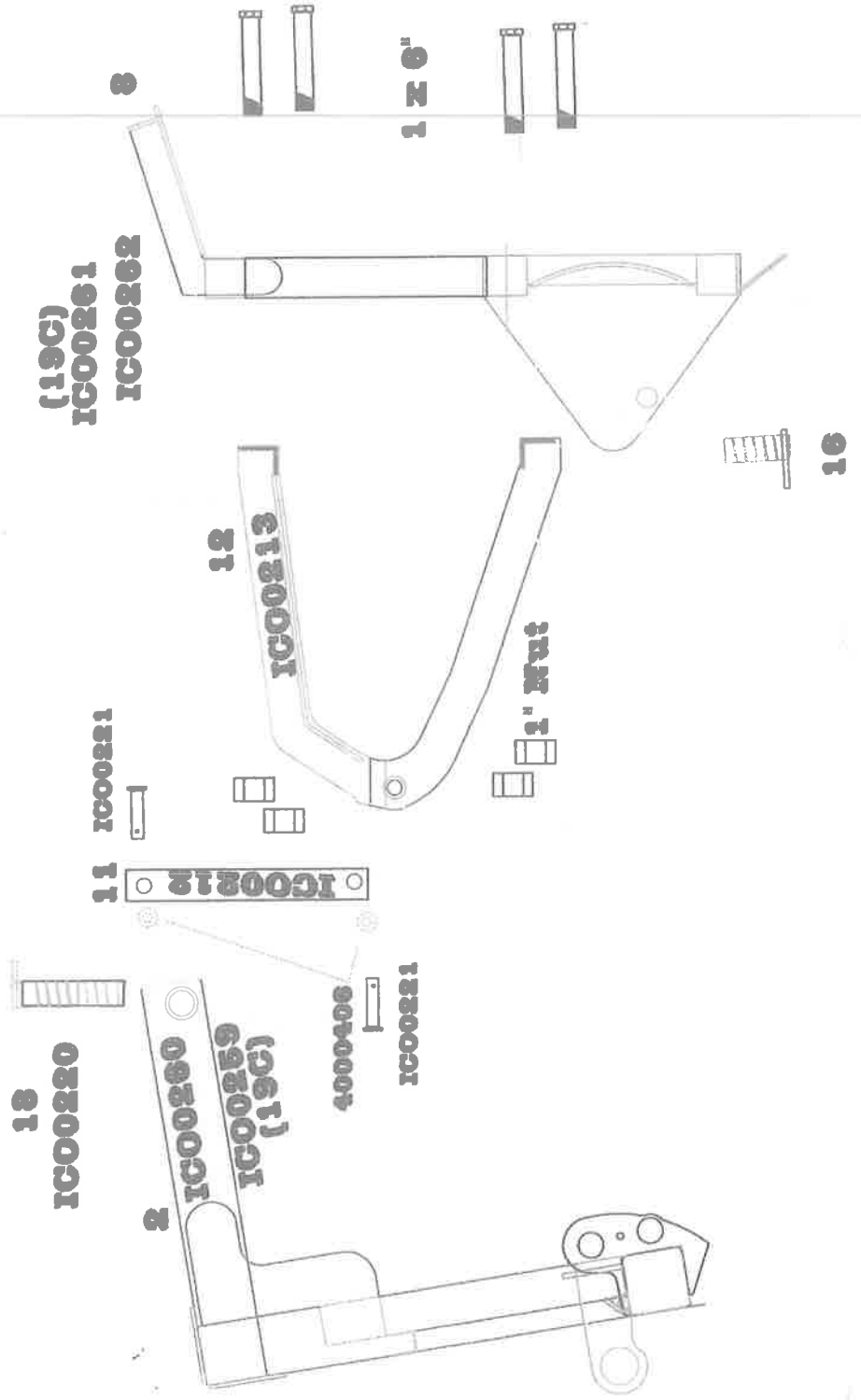

Clam and Gate Arm Model C

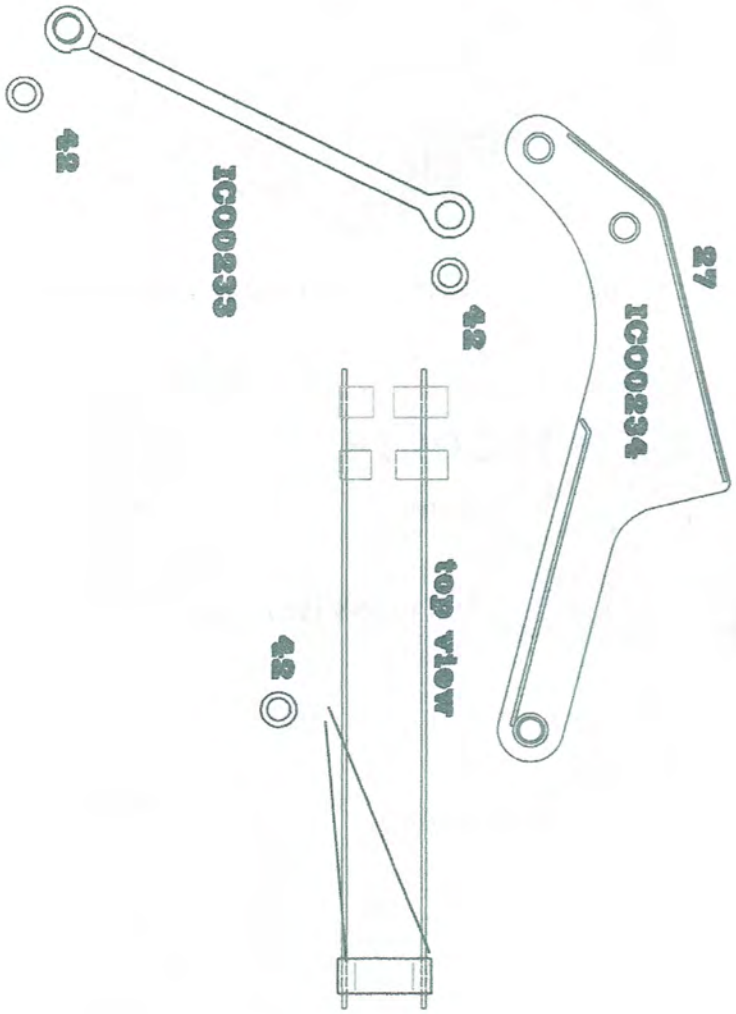
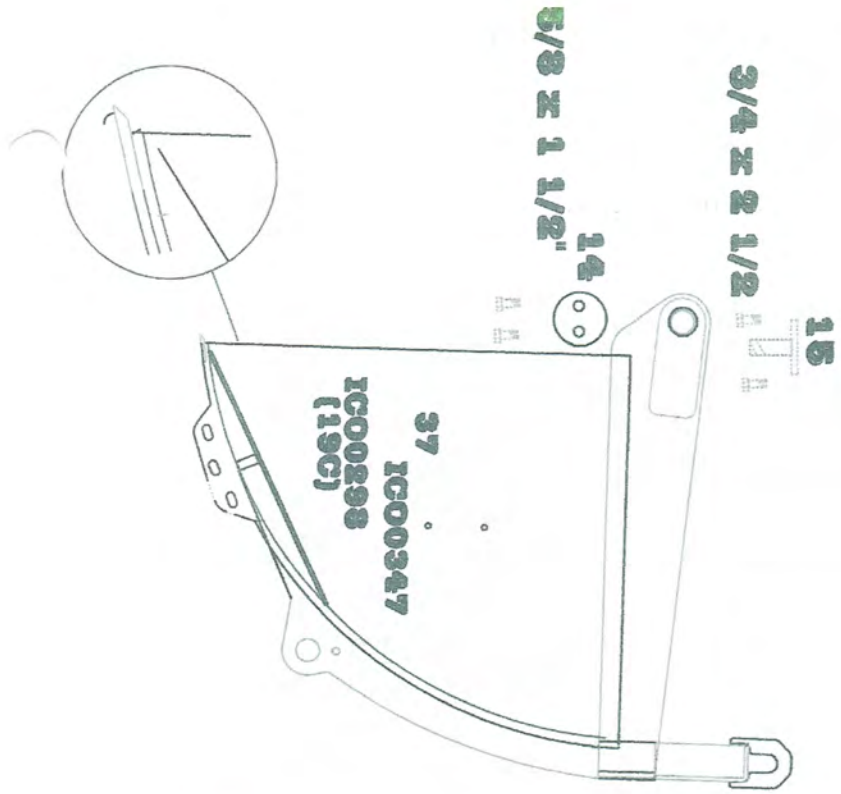

Information, Maintenance Section

The following shows bolt locations and pin sizes.

Below shows the center rear frame pin and it's components.



The grease lines are shown attached to the swing wall roller, and the push off cylinder pin.



Information, Maintenance Section

Push Off Frame

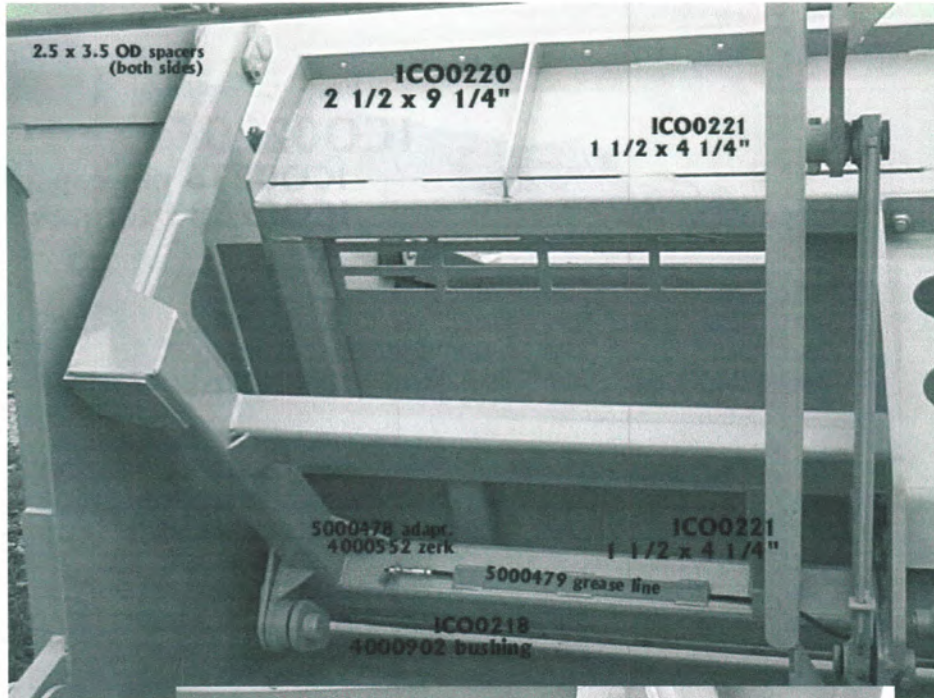

Push Off Frame

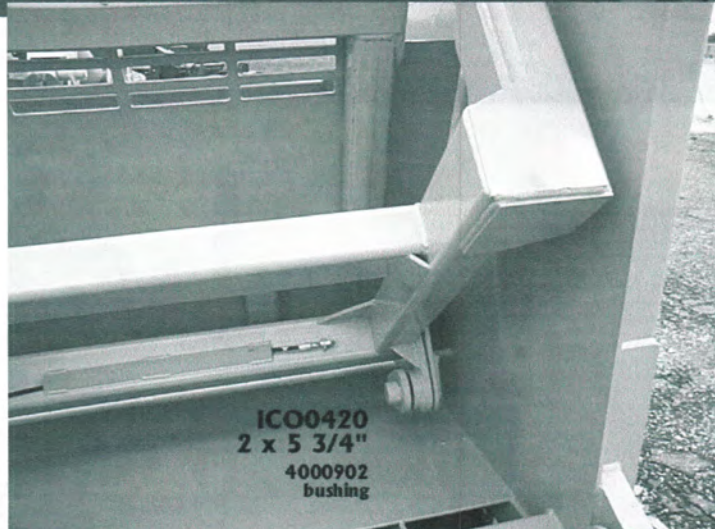

Swing Wall Linkage

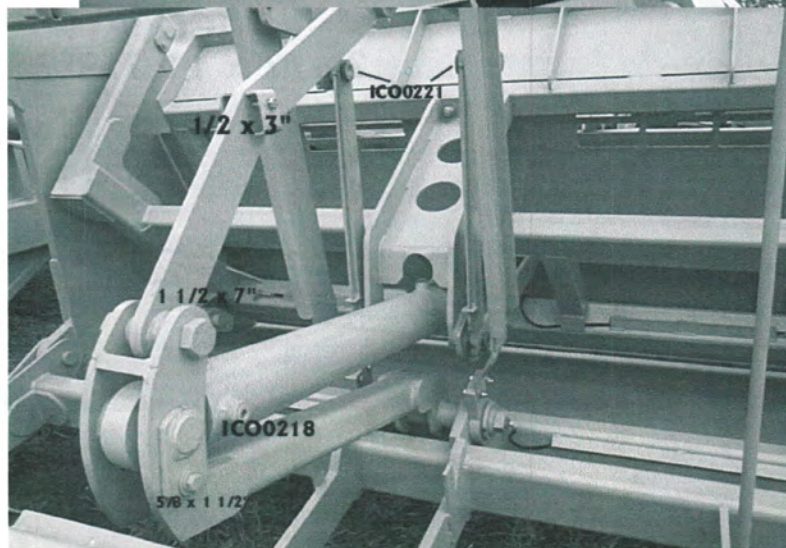

Side and Front View



Gate Pivot Arm

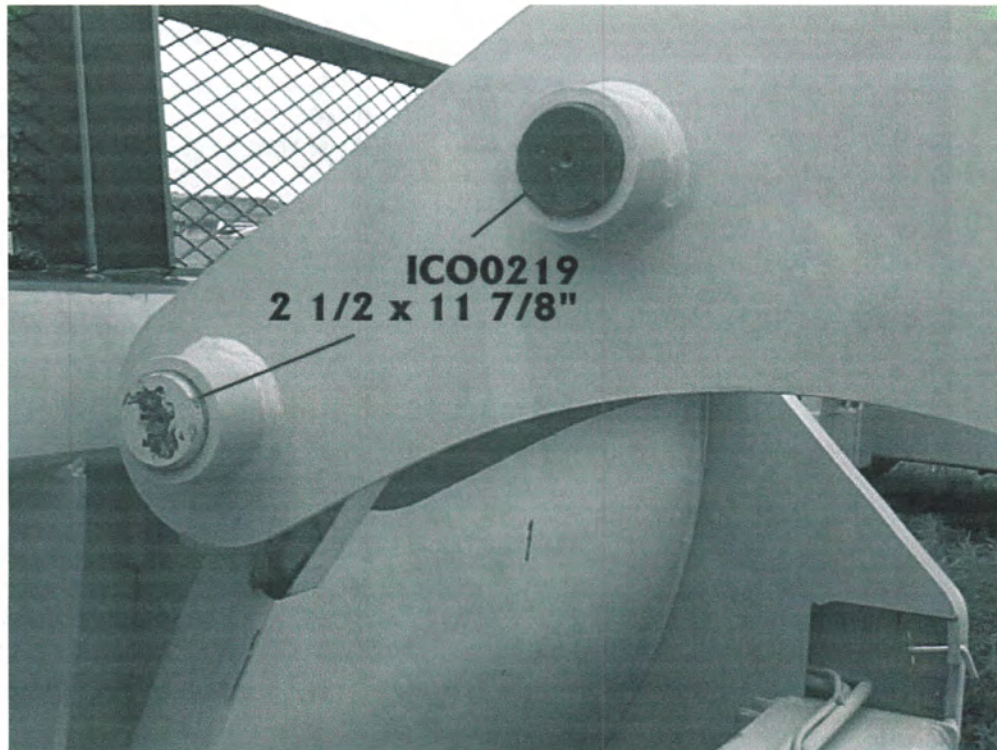

Lower Pin On Front Gate

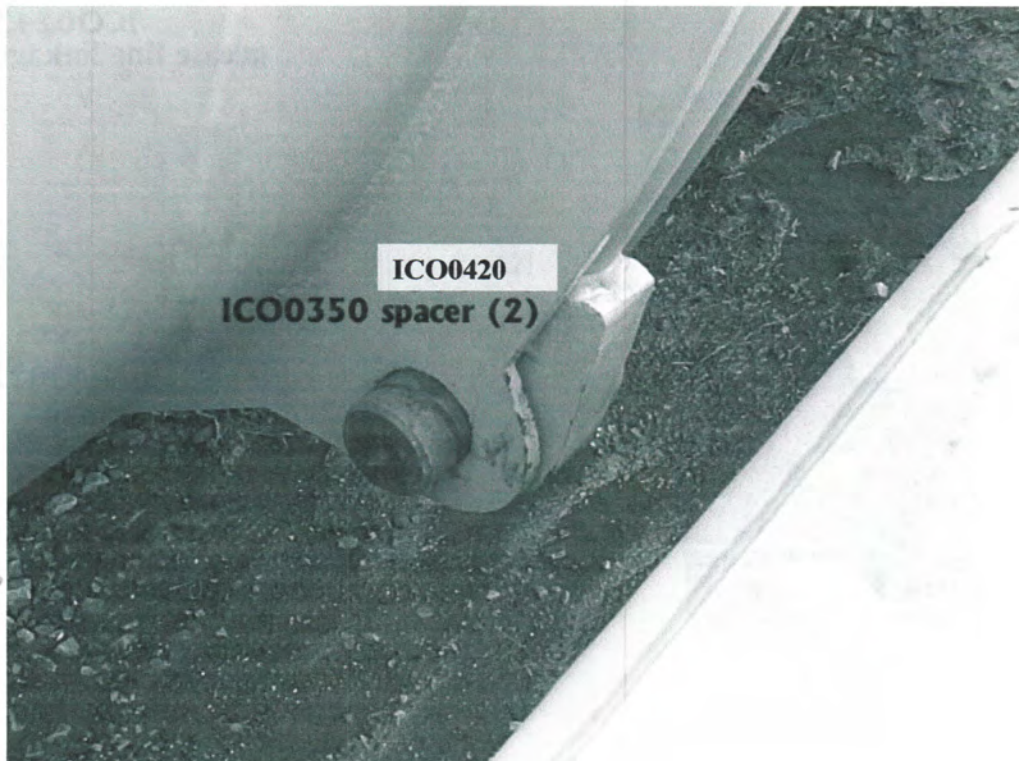

Information. Maintenance Section

Top View Of
Push Off
Linkage



Shown From The Back

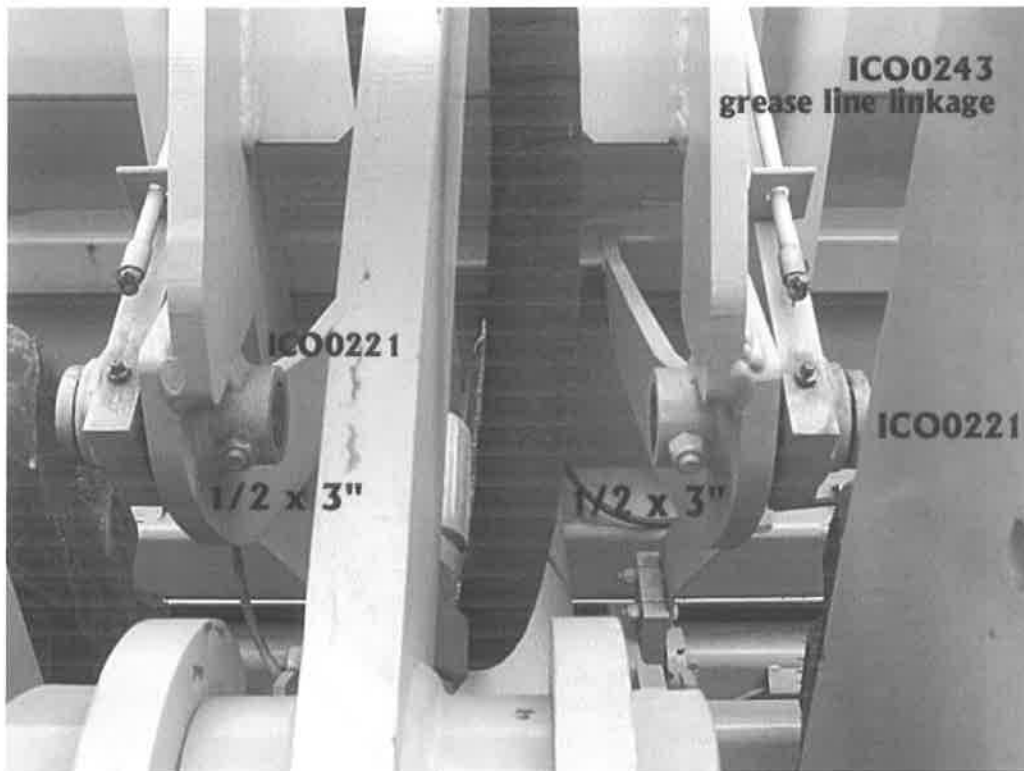

Lift Cylinder (top)

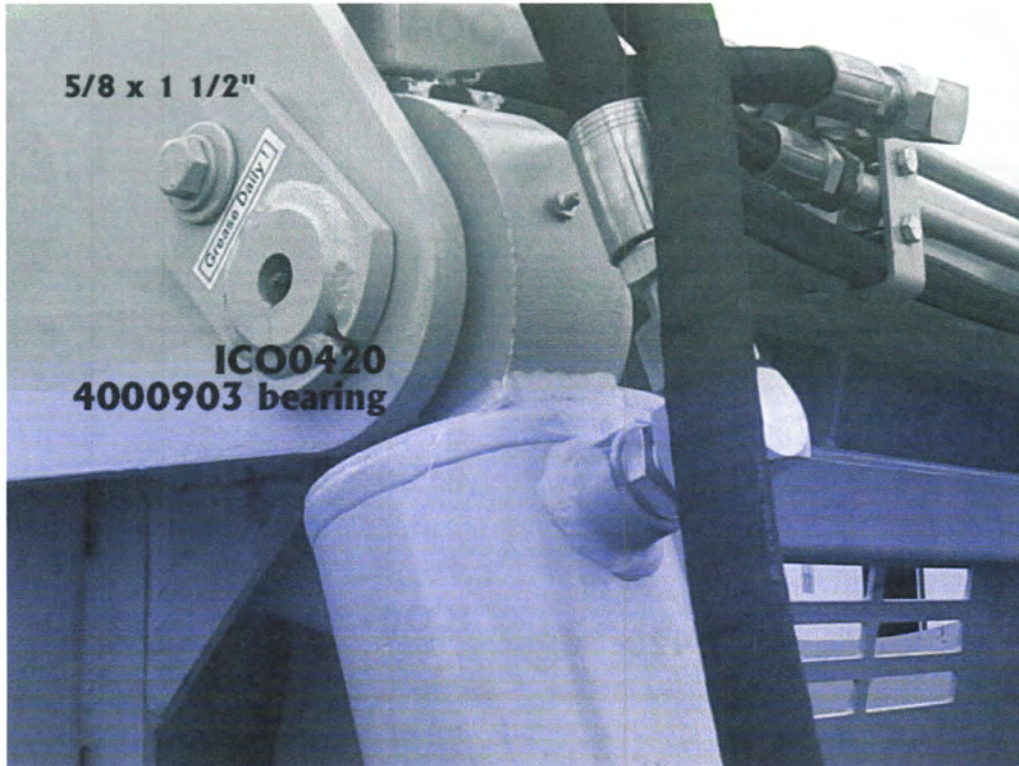

Lift Cylinder
(bottom)

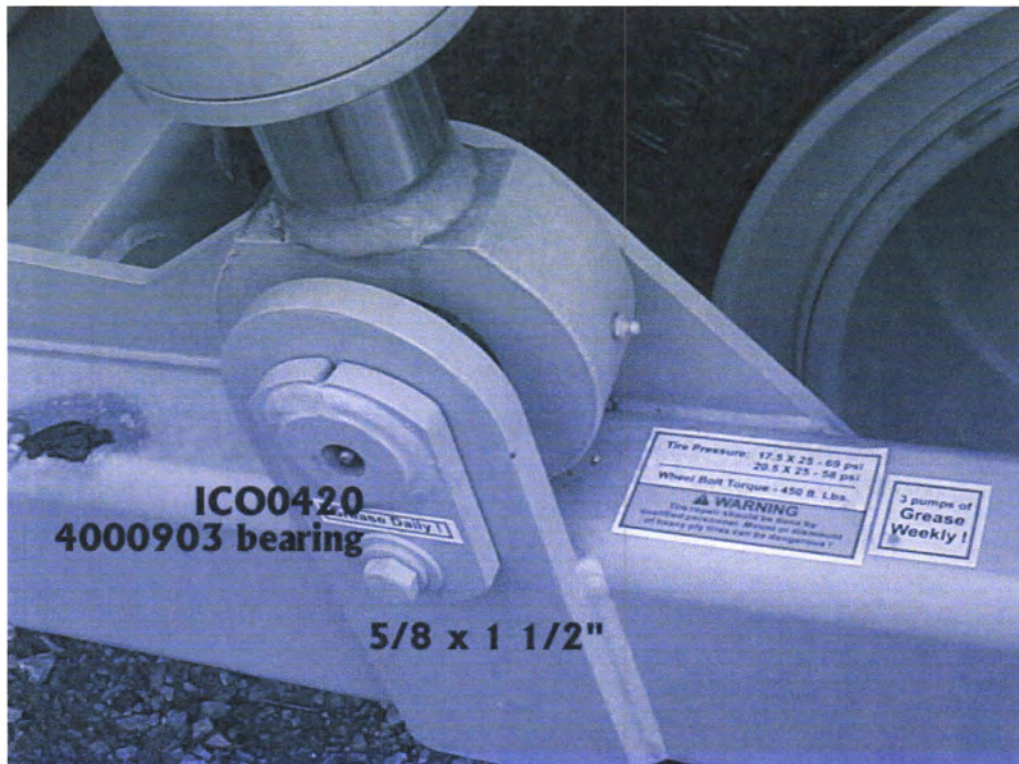



Lower View Of Rear Frame



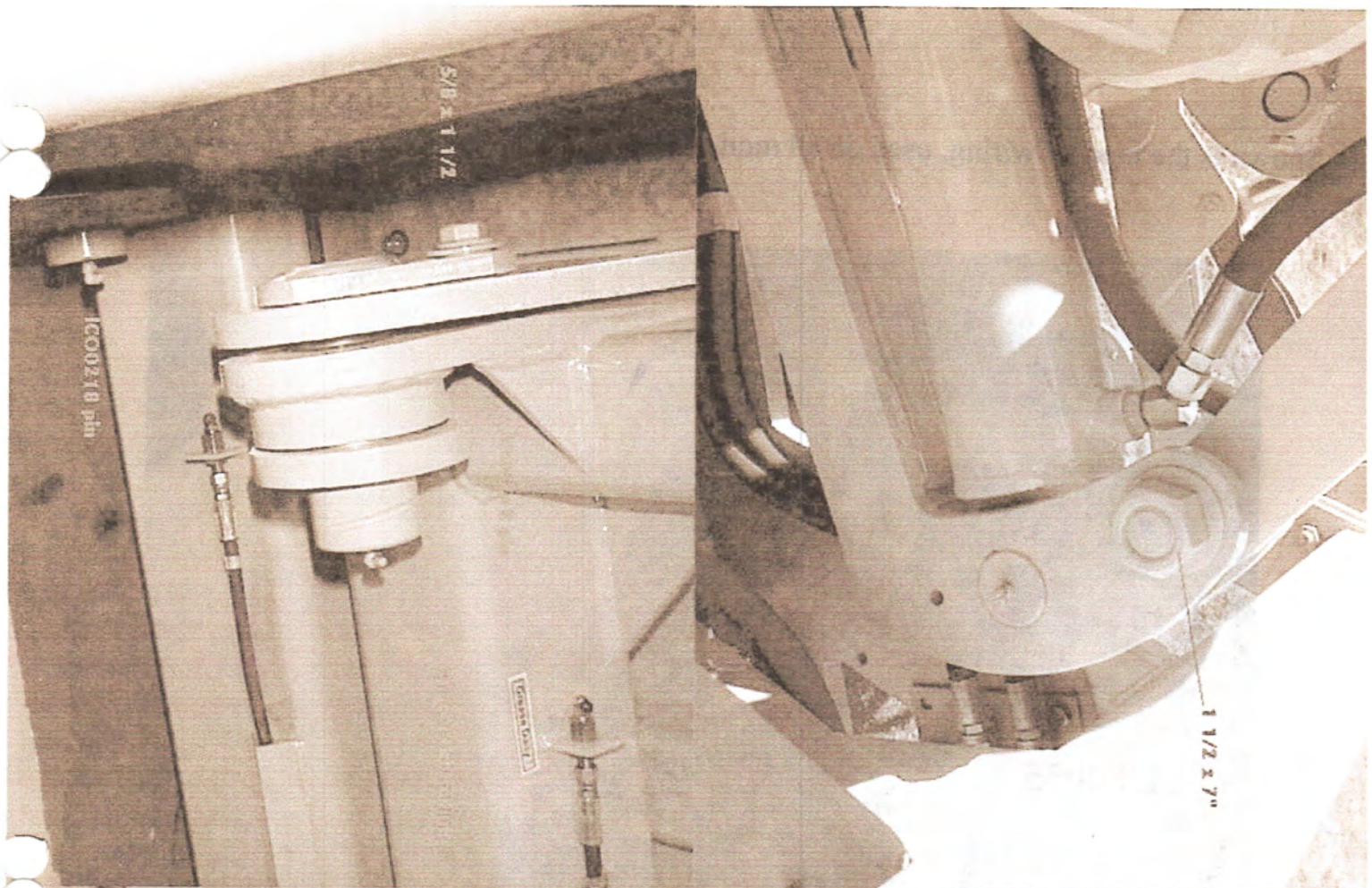

1 1/2 x 7"

2.5 x 3.5 OD Washers
Adjust clearance on
PO Arms

ICO0216 pin cap
5/8 x 1 1/2" bolts

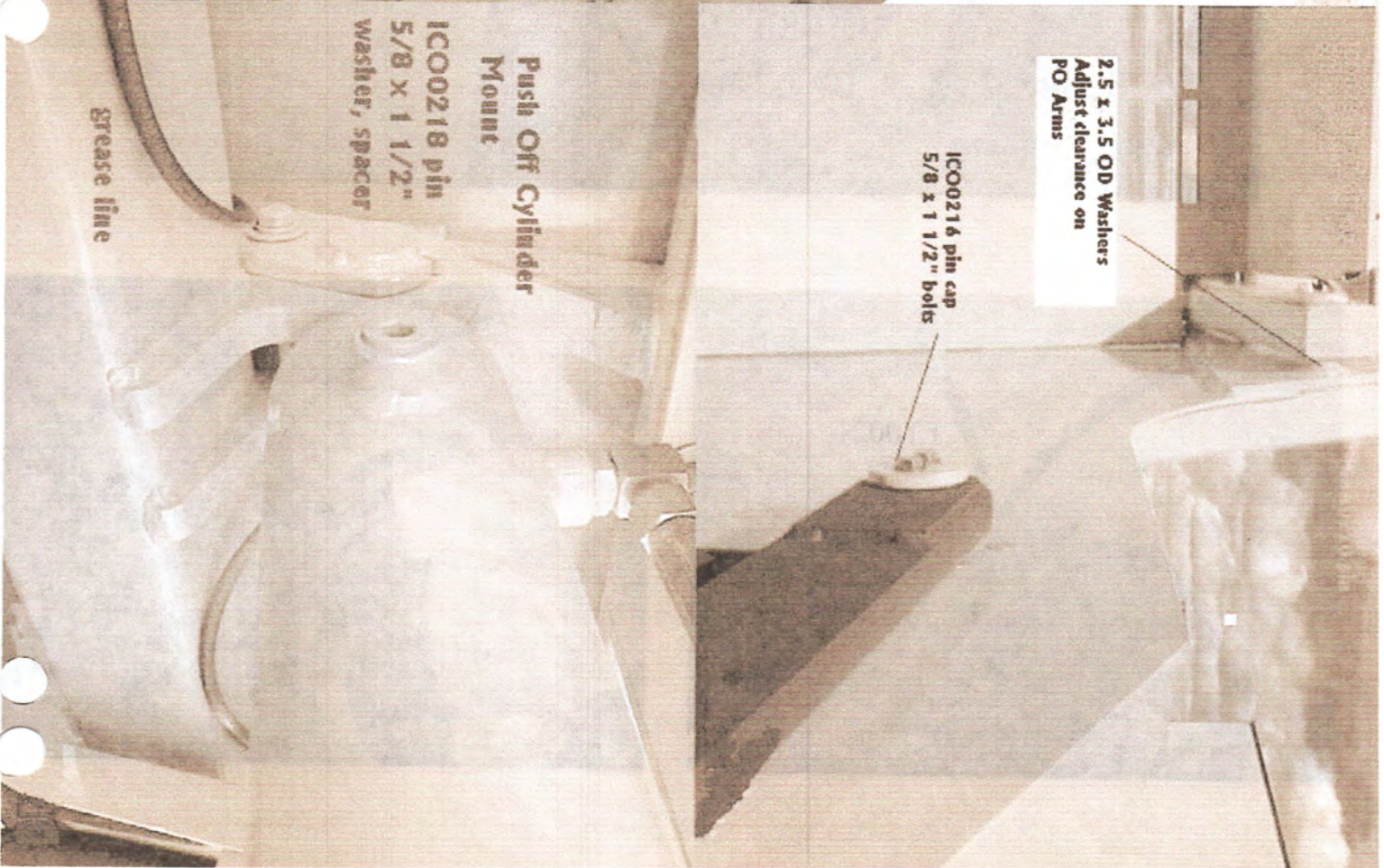

Push Off Cylinder
Mount

ICO0218 pin
5/8 x 1 1/2"
washer, spacer

Grease line

Shown is the tandem wiring, used on all models.

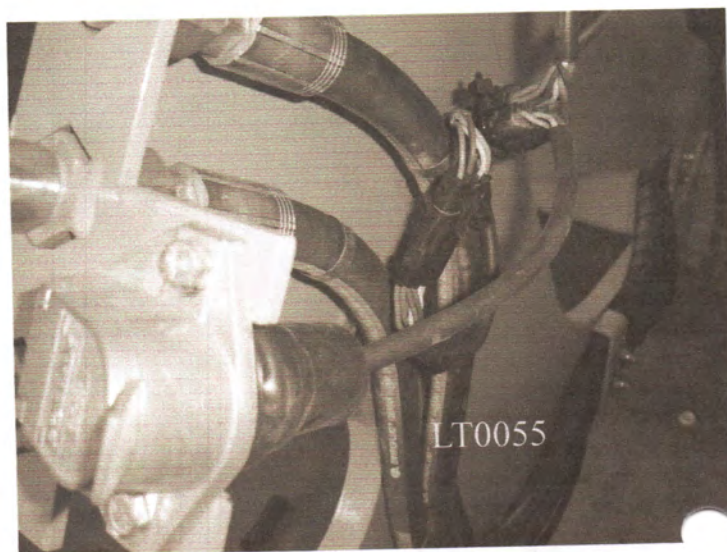
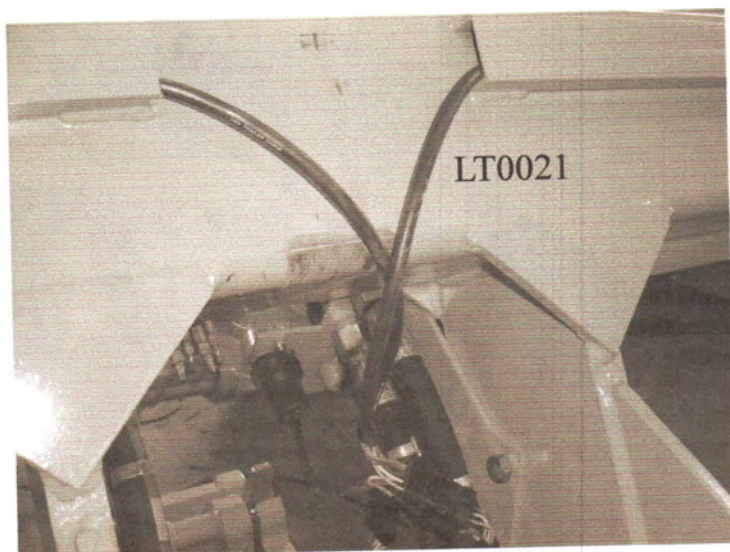
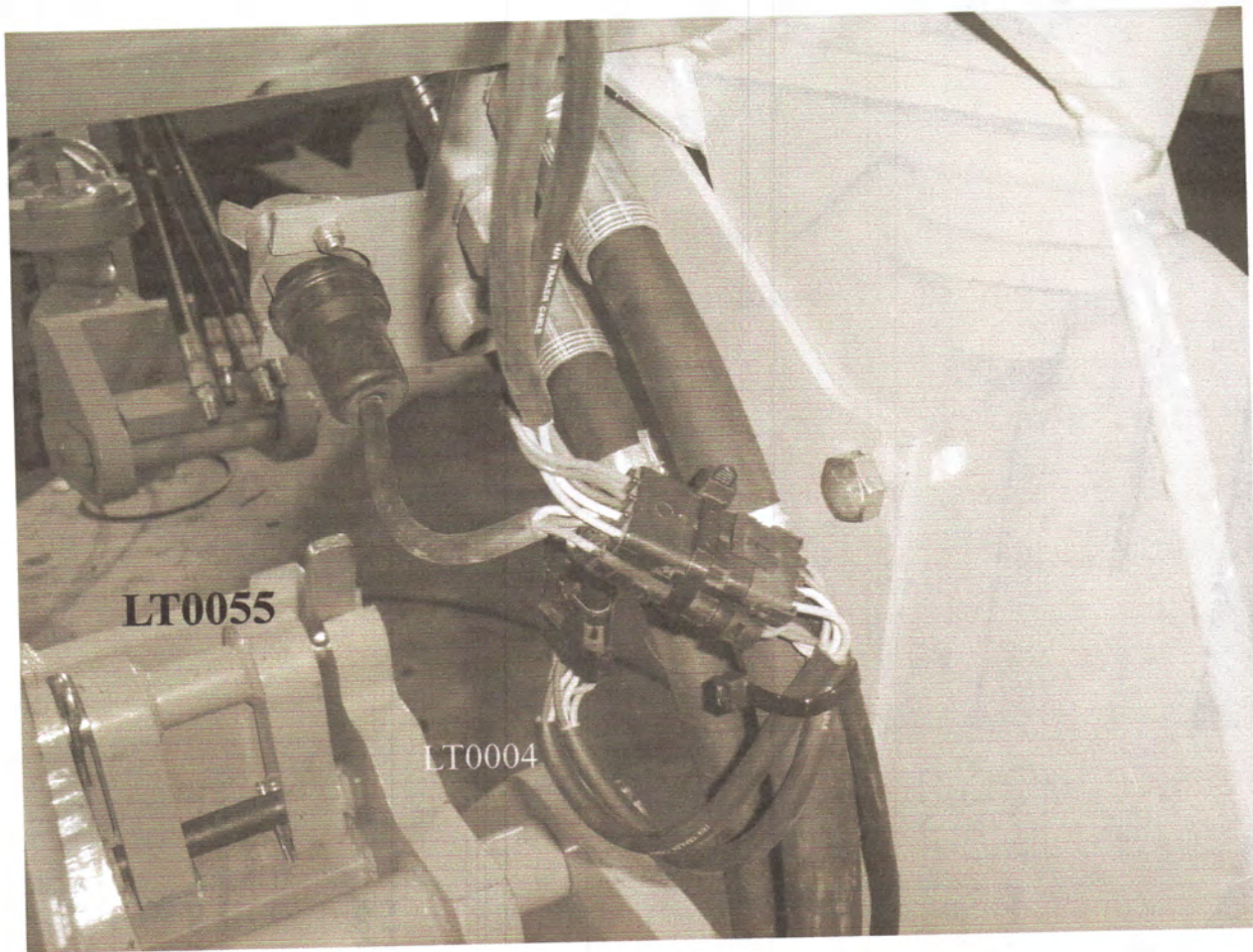

The 3/16" roll pins should be installed by drilling two holes opposite each other, in each end, through the rim of the outer seal. This is to help prevent movement of the seal and aid in its grease retention.

Rear Axle Assy. C,D,E & 1121

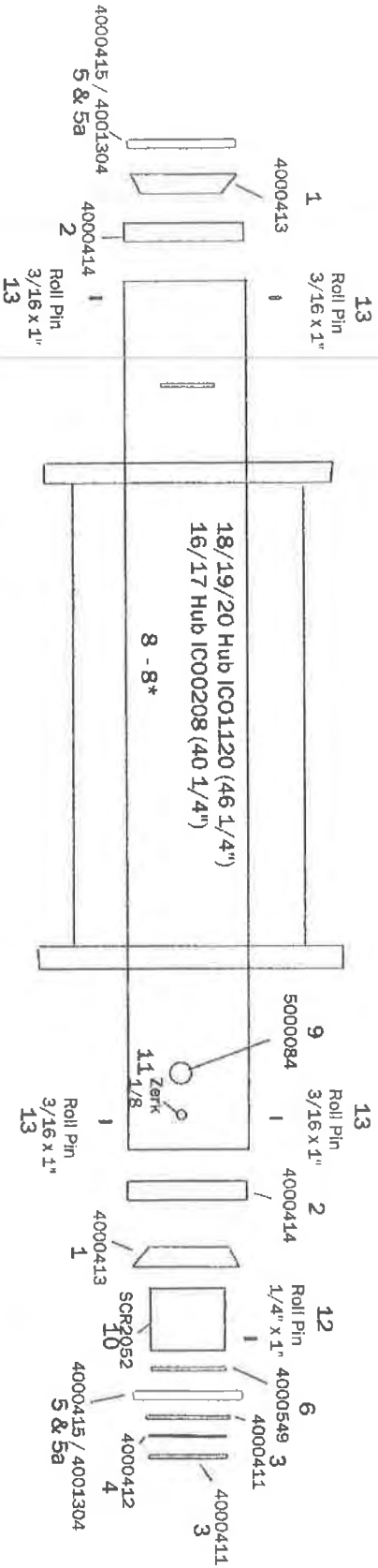

1. 4000413 Bearing, 580 Timken Cone
2. 4000414 Bearing, 572 Timken Cup
3. 4000411 Bearing, Nut E2305
4. 4000412 Bearing, Lock Washer
5. 4000415 Bearing, STEMCO seal 392-9095
- 5a 4001304 Seal (new style) CR42627
6. 4000549 Hyd. O-Ring 3.25-3.50
7. SCR2034 18/19/20 Rear Axle
8. IC01120 18/19/20 Rear Hub
9. 5000084 Hyd. Plug 1/2" pipe
10. SCR2052 Axle Spacer
11. 4000067 Zerk, Straight 1/8"
12. PR 1/4 Roll Pin 1/4 x 1"
13. PR 3/16 Roll Pin 3/16 x 3/4"
- 7* IC00207 16-17 Axle
- 8* IC00208 16-17 Hub

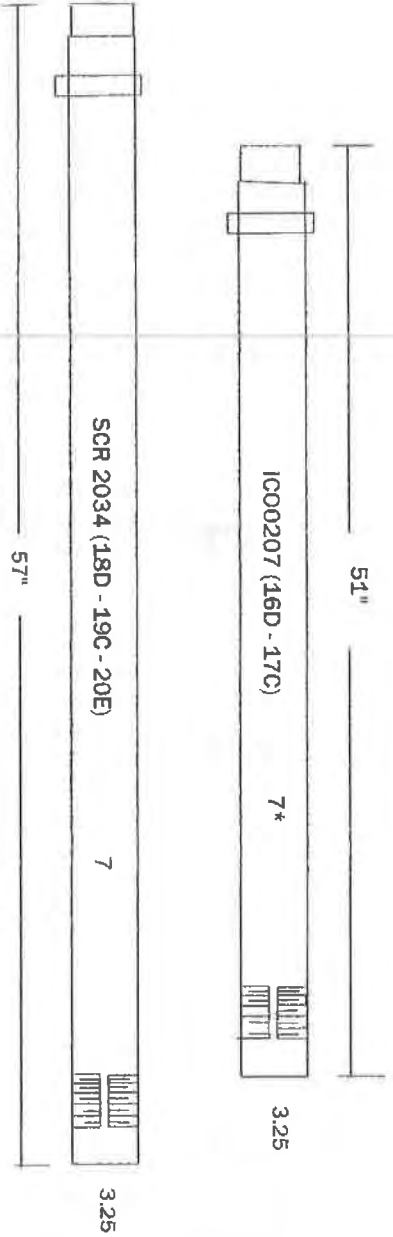

Complete Assemblies

16D/17C 2000212

18D/19C/20E 2000499 - DISCONTINUED

2000589 - NEW

Technical Section

Below is shown the Quick Attach Hitch. The components are shared by the rear tandem hitch, and the Contractors Hitch, that mounts on the tractor.

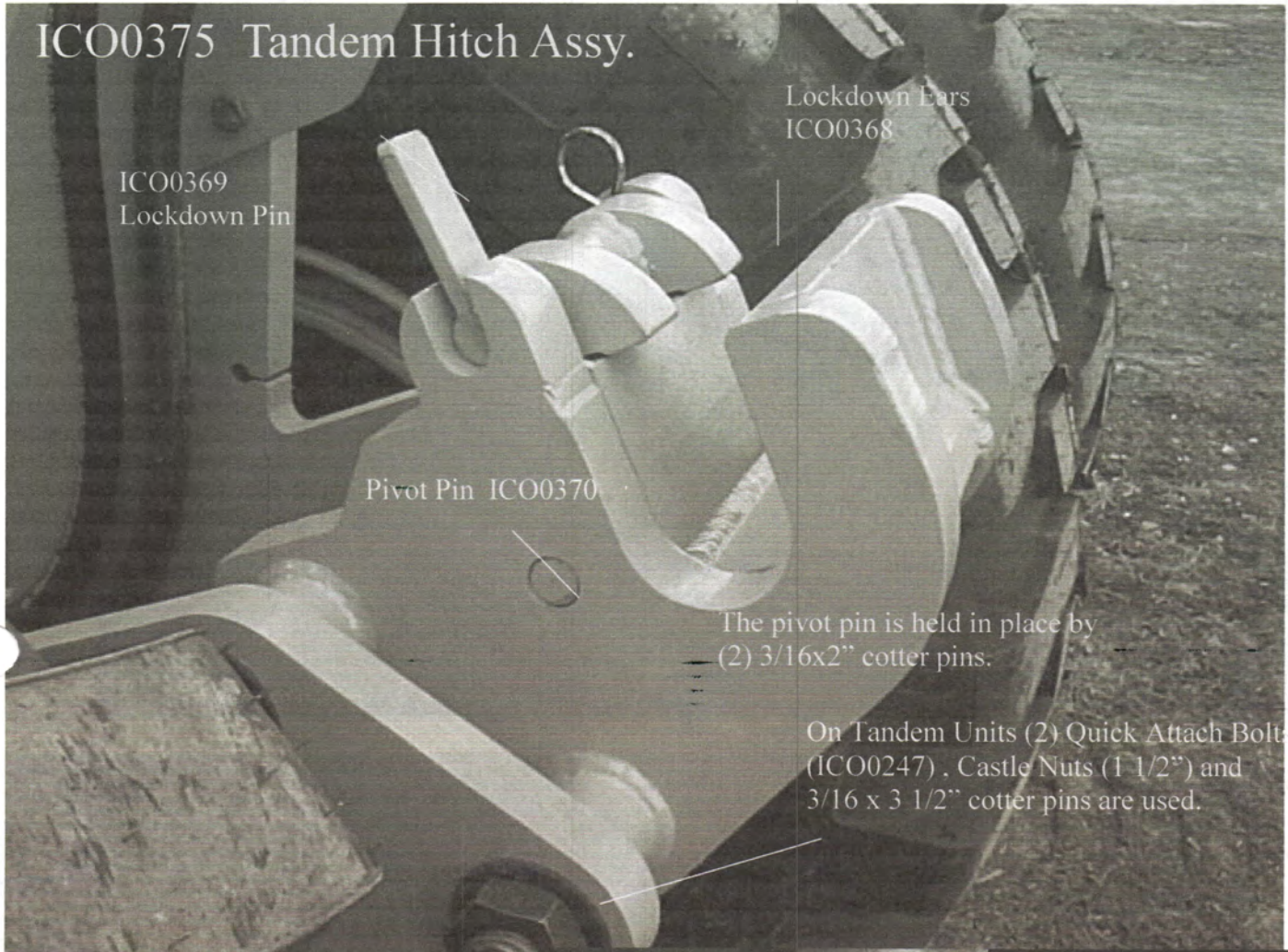

Shown is the Quick Attach pin and adapter. These slip into the yoke on the drawbar or tandem hitch, and lock into place with the ears and lockdown pin.

Mounting/Dismounting of either Earthmover, is shown in the Service Section.

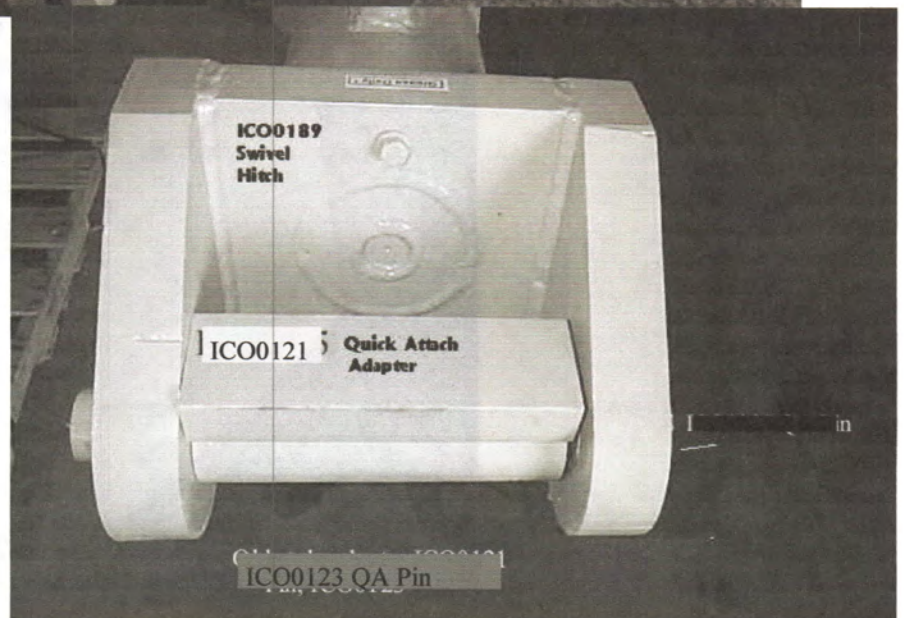

Hitches & Axles

Shown below is the drawbar that is currently used on the MT Series Challenger tractor. It features the ICON Quick Attach, and works with all ICON swivel hitches. If the tractor is a Contractor's Model, the drawbar is all that is needed to attach the Earthmover.

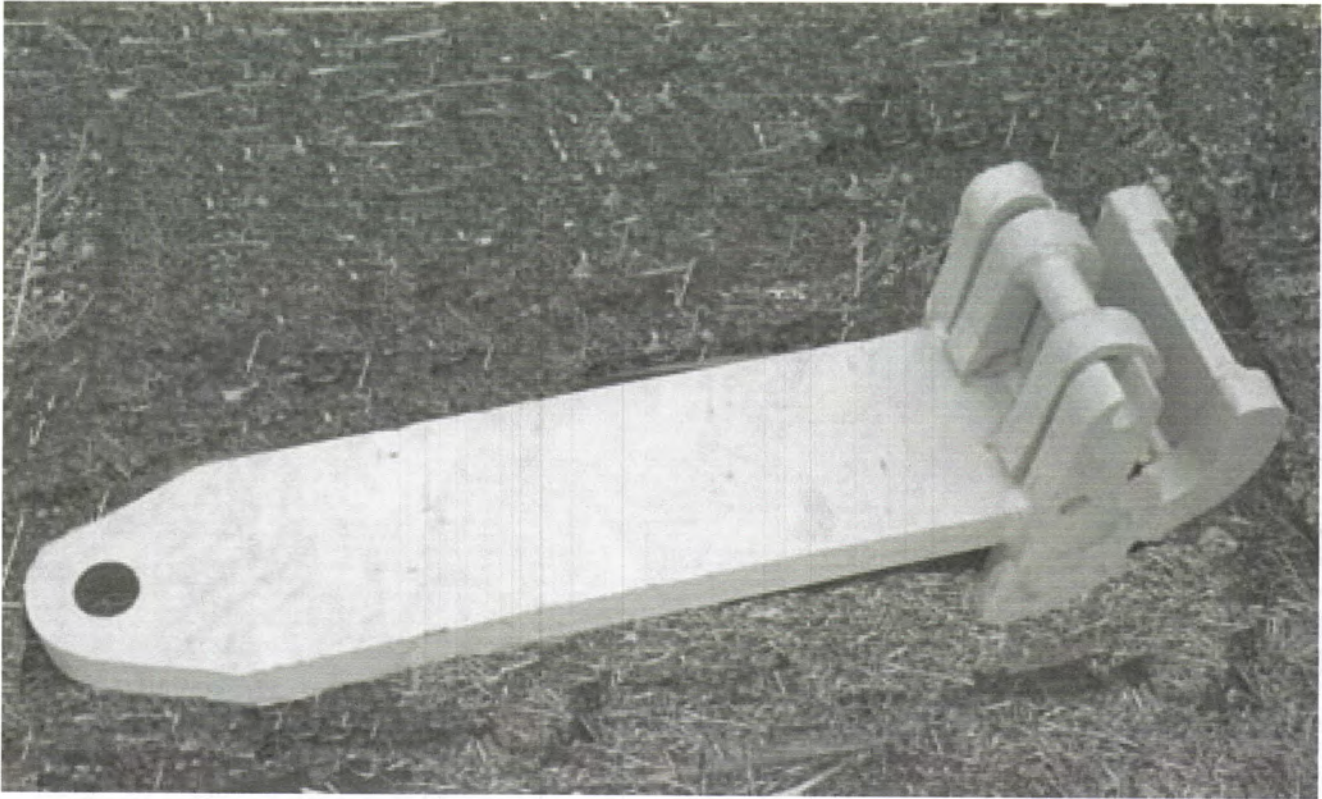

If the MT tractor is the Ag Model, the Contractor's Hitch back plate is available.

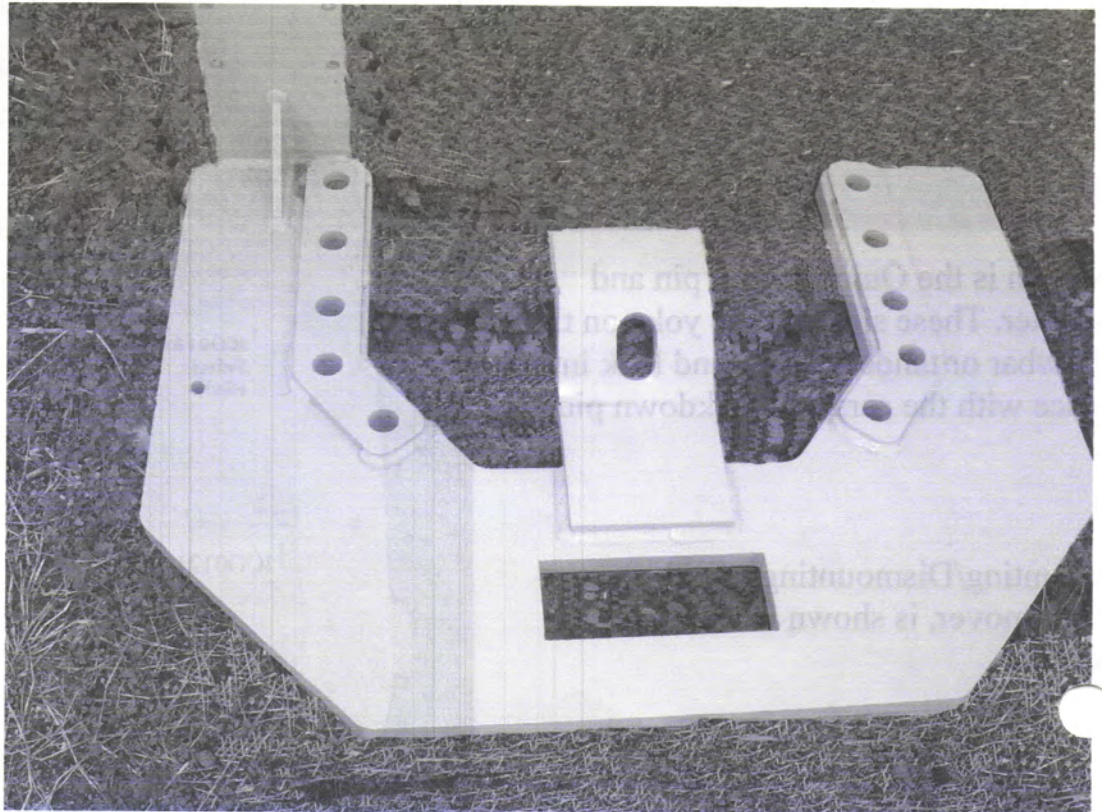

Hitches & Axles

Shown below is the SD 360 (Super Duty). It is standard equipment on the C Series and available as an option, on the D Series. The SD features a full 360 degree rotation, of the front swivel. This will help to prevent damage to the pulling unit, in the case of a rollover. Also, the swivel may be rotated 180 degrees to slightly adjust the cutting angle. This will aid in the loading of hard material or loose and sandy soil. The decals, located on the side of the hitch will help to explain which direction is best suited for the type of material being loaded.

A 2 pound grease reserve is built into the horizontal tube, which aids in longer life, and better lubrication. The caps are hardened and have milled grooves for wiper seals, to prevent grease from escaping. The hitch is attached to the scraper with (6) 1 1/2" grade 8 bolts.

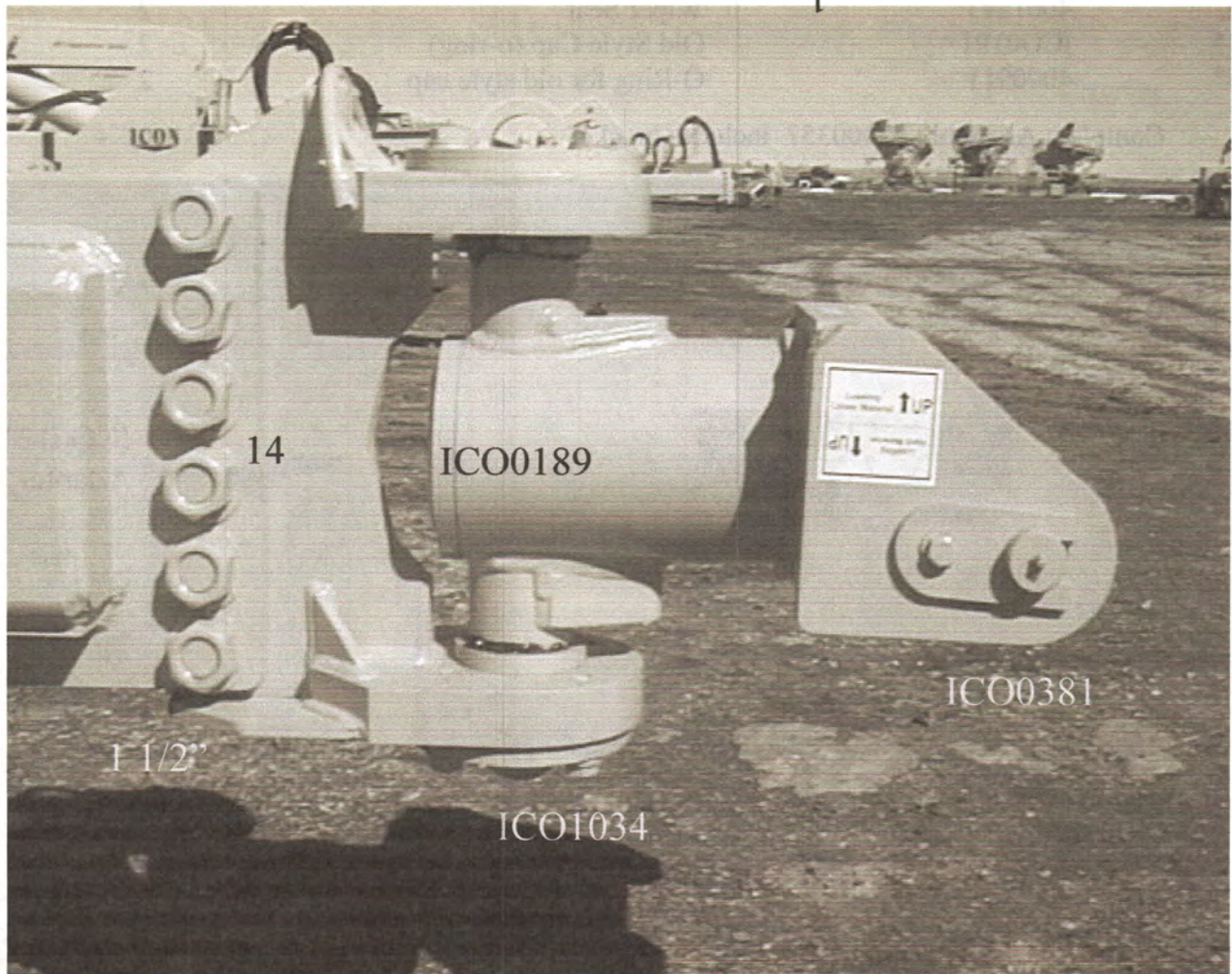

See following pages for part #'s and breakdown of the SD.

Swivel Hitch Parts List

Standard on Model C's - Optional on the 18D Series

Ref#	Part#	Description	Qty
1.	ICO0189	Swivel Hitch Assy.	1
2.	ICO0121	Quick Attach Adapter	1
2a	4001291	Wiper Seal (QA Adapter)	2
3.	ICO0123	Quick Attach Pin	1
4.	ICO0198	Pin Keeper	1
5.	4000844	Bushing	2
6.	BH 5/8	Bolt, Hex 5/8 x 1 1/2" (gr 8)	2
7.	ICO0090	Pin Spacer 9/16"	1
8.	WFH 5/8	Washer, Flat, Hard 5/8"	2
9.	WF 5/8	Washer, Flat 5/8"	2
10.	BH 3/4	Bolt, Hex 3/4 x 3" (gr 8)	8
11.	ICO0192	Swivel Hitch Thrust Washer	2
12.	WFH 3/4	Washer, Flat, Hard 3/4"	16
13.	ICO1034	Swivel Hitch Cap	2
14.	ICO0190	Swivel Hitch Bracket	1
15.	4001243	Wiper Seal	2
13*	ICO0191	Old Style Cap (o-ring)	2
15*	4000911	O-Ring for old style cap	2

Complete Assembly #2000357 includes bracket

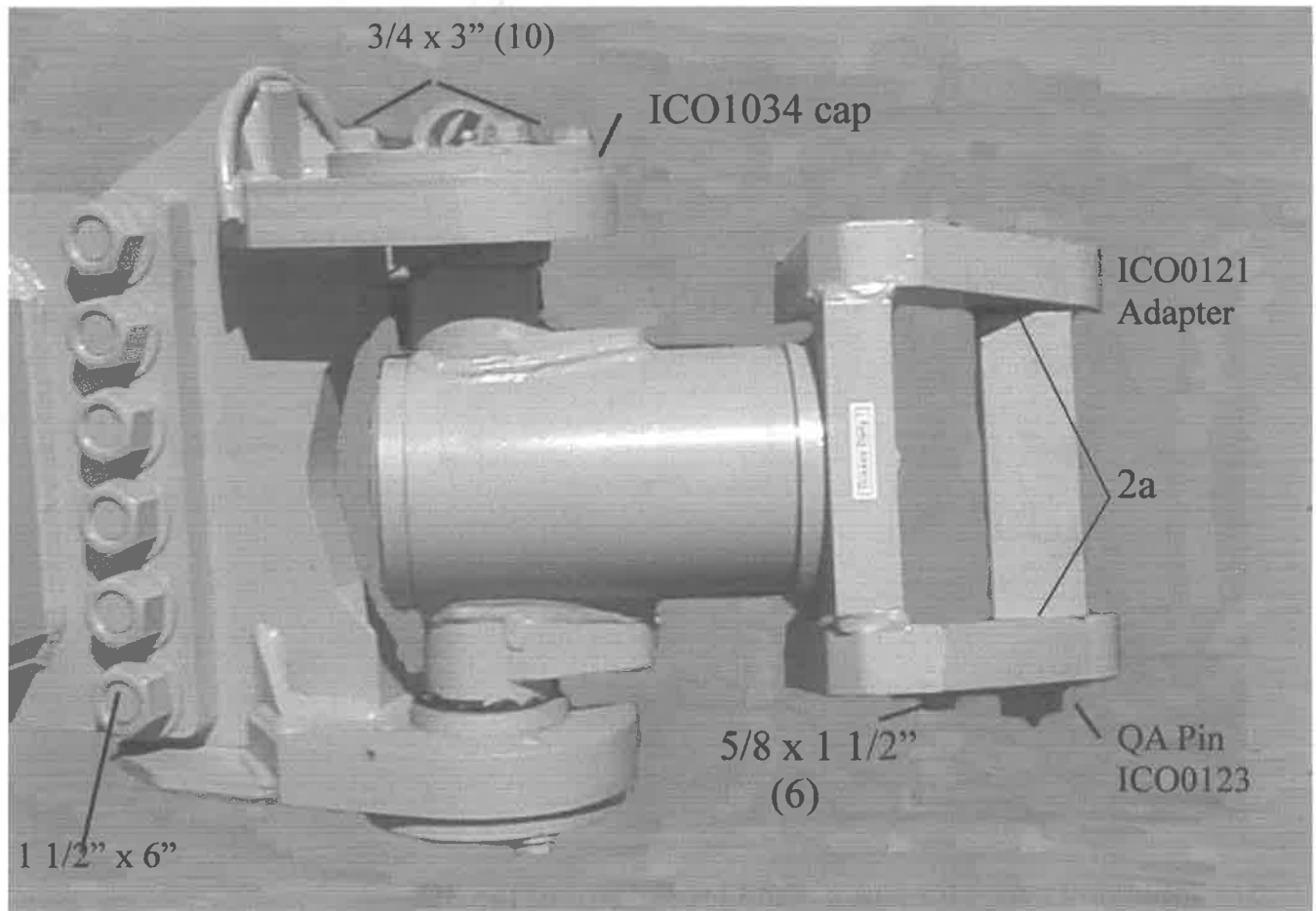

Series 2 cap has a wiper seal for better grease retention.
IC01034

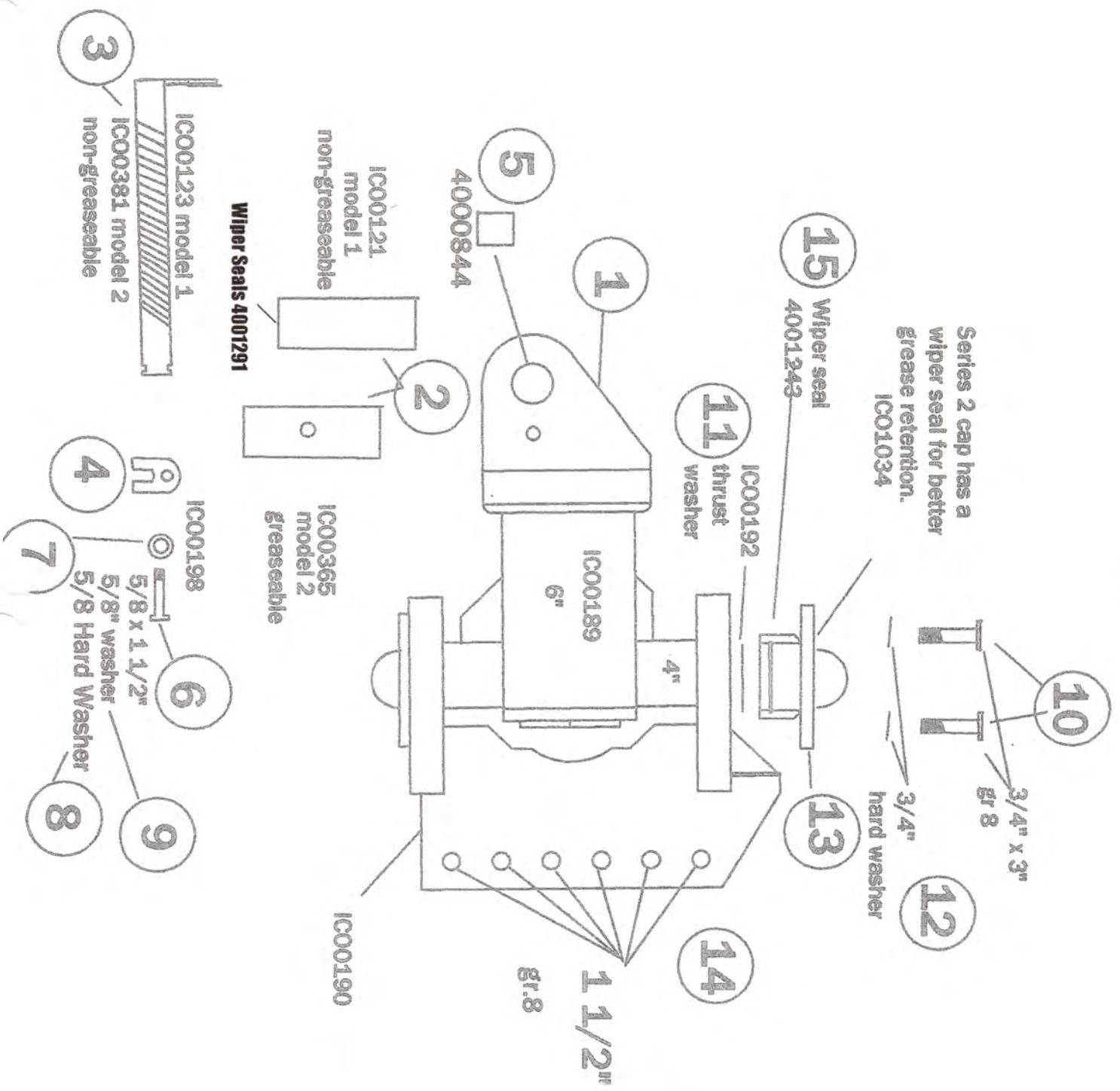

IC00123 model 1
IC00381 model 2
non-greaseable

IC00121 model 1
non-greaseable
Wiper Seals 4001291

IC00365 model 2
greaseable

IC00198

IC00190

1 1/2"
gr. 8

3/4" x 3"
gr 8

3/4"
hard washer

IC00192
thrust washer

IC00189
6"

4"

3

5
4000844

1

2

4

7

6

9

8

10

12

14

15

Wiper seal
4001243

13

Part #'s and Breakdown of the SD Hitch

Complete Unit Including Bracket 2000357

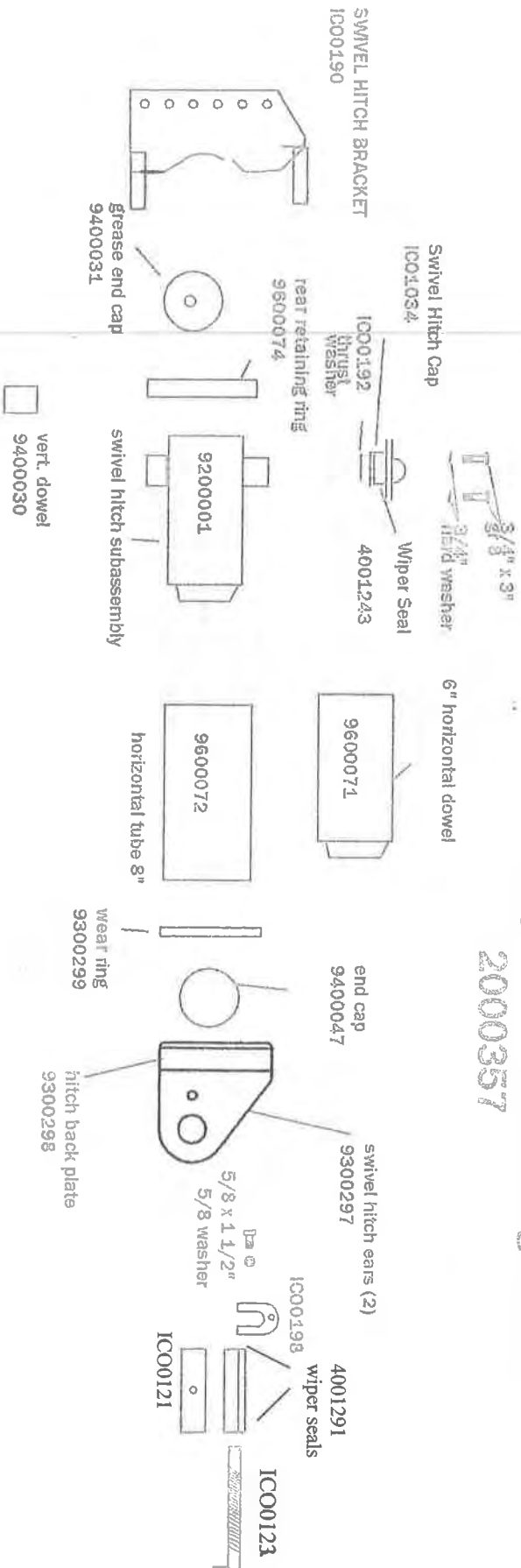

4000922

3/4 X 3" (3 EA)
Plow Bolts

IC00206 L & R

3/4 X 2 1/2" (5EA)
PLOW BOLTS

Ejection Wall Wear Strip
1/2 x 1 1/2 Carriage Bolt
12 total

19C/20E — IC00204
IC00304 — 17C

18D — 518 — IC00340

Cutting Edges
1 x 2 1/2 Gd 8 Plow Bolt
16D-17C — 20 bolts
18D - 19C — 22 bolts
518 — 22 Bolts

Model	Location	Dimensions	ICON#	CAT#
18D/19C/17	(2) Side	7/8x13x35.75	4000851	178-4080
20E	(1) Center	7/8x16x60	4000951	174-8001
17C	(1) Center	7/8x16x48	4000958	174-8002
518	—Same as 18D			

Bolt Holes Per Blade

4000851.....	6
4000958.....	8
4000951.....	10

Hardware Required To Install Cutting Edges

- 1" x 2 1/2" Grade 8 Plow Bolt
- 1" Grade 8 Jam Nut
- 1" Hardened Flat Washer

**Side Cutting Edges
Model C, D and E & 518**

ICO0206 Left and Right

Each Part Requires (5) 3/4" x 2 1/2" Plow Bolt, Washer, and Nuts

Rear Cutting Edges

4000922.....Each uses (3) 3/4" x 3" Plow Bolt, Washer, and Nuts

Wear Strips

ICO0304 (17C)

ICO0204.....(2) pieces—1/2" x 1 1/2" Carriage Bolt (12 total)

ICO0340 (18D)

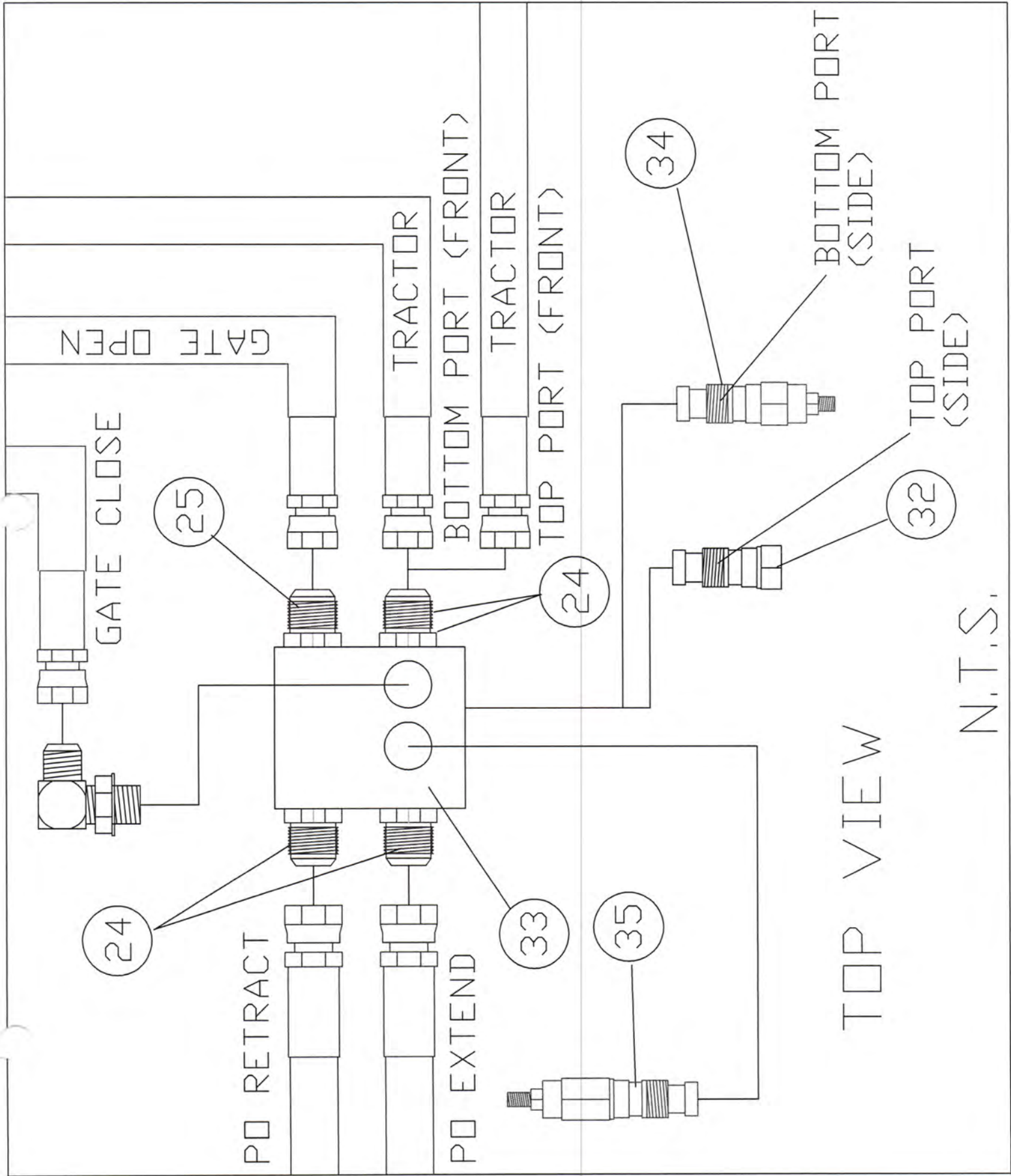

TOP VIEW

N.T.S.

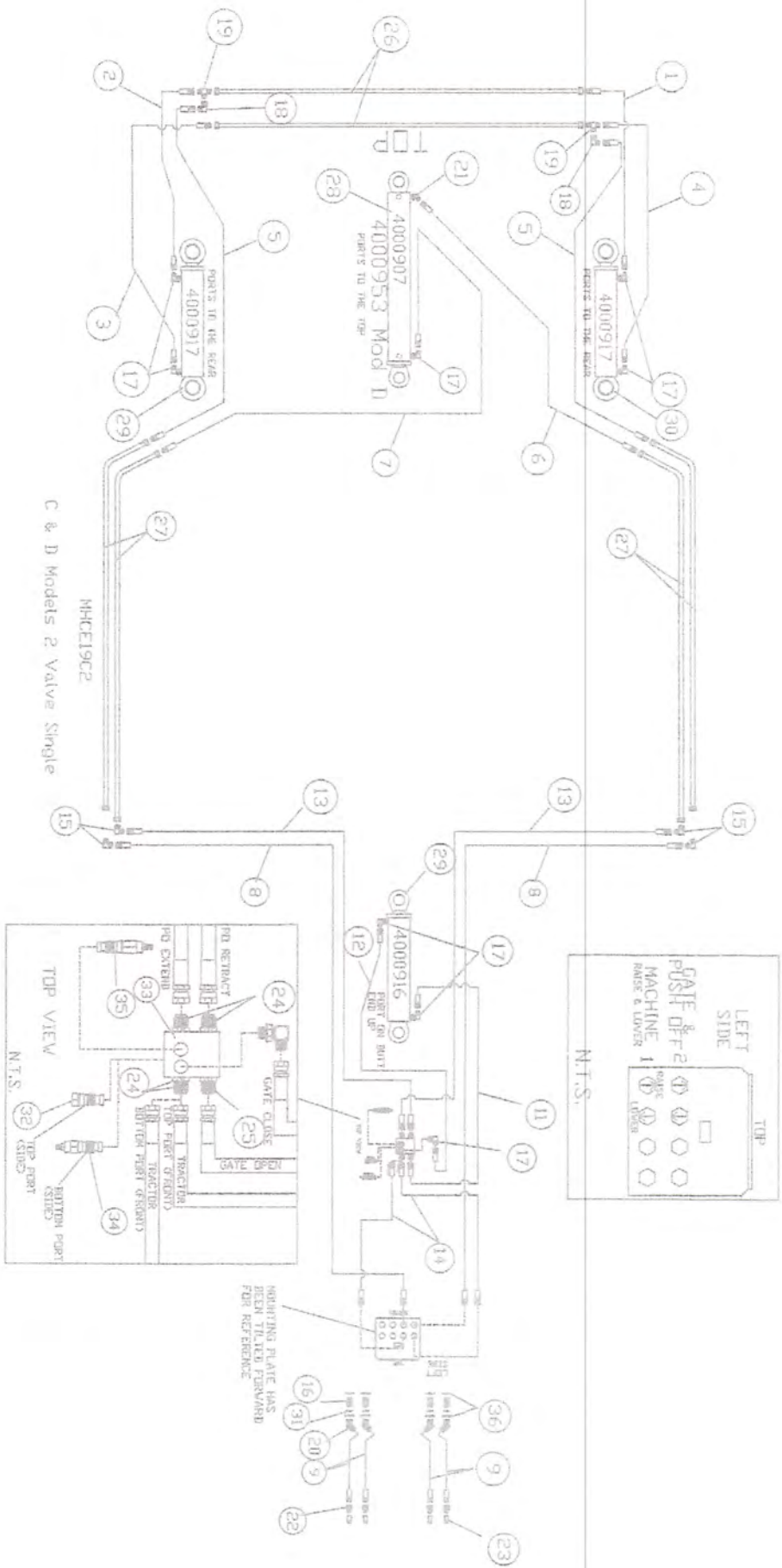

2 VALVE SINGLE

SERIES C & D
Manual Hydraulics Parts List
(2 - Valve)

REF#	PART #	DESCRIPTION	QTY.
1.	5000671	Hose, 12FJX - 12C12x42 Cut - 16MJ	1
2.	5000672	Hose, 12FJX - 12C12x42 Cut - 16FJX	1
3.	5000673	Hose, 12FJX - 12C12x34 Cut - 16MJ	1
4.	5000674	Hose, 12FJX - 12C12x34 Cut - 16FJX	1
5.	5000675	Hose, 12C12MGS/16MJ/16FJX 39.5"	2
6.	5000676	Hose, 12FJX-12C12x115 Cut-16MJ	1
7.	5000677	Hose, 12FJX-12C12x116 Cut-16MJ	1
8.	5000652	Hose, 16FJX - 12C12x120 Cut - 16FJX	2
9.	5000653	Hose, 12MP - 12C12x84 Cut - 16FJX	4
10.	5000479	Hose, 4FJX - 3C1Tx48 Cut - 2MP	3
10a.	5000478	Hyf - Adap JIC 4MJBH-2FP	3
11.	5000664	Hose, 12FJX - 12C12x31 Cut - 12FJX	1
12.	5000665	Hose, 12FJX - 12C12x54 Cut - 12FJX	1
13.	5000654	Hose, 12FJX - 12C12x76 Cut - 16FJX	2
14.	5000655	Hose, 16FJX - 12C12x36 Cut - 16FJX	2
15.	5000620	Hyf - El, JIC 16MJ - 16MJ90	4
16.	5000622	Hyf - Bushing, JIC 16MJ - 16MJ	4
17.	5000630	Hyf - El, JIC 12MB - 12MJ90	9
18.	5000631	Hyf - El, JIC 16MJ - 16FJx90	2
19.	5000633	Hyf - TEE, JIC 16MJT	2
20.	5000640	Hyf - El, JIC 16MJ - 16FJx45	8
21.	5000644	Hyf - El, JIC 12MB - 12MJ45	1
22.	5000836	Hyf - Adap. 10MB-12FB	4
23.	5000835	Hyf - PIONEER 7/8 M End 8010-16P	4
24.	5000660	Hyf - Adap JIC 12MB - 16MJ	4
25.	5000698	Hyf - Adap JIC 12MB - 12MJ	1
26.	5000625	Hyd - Tube 16FJ - 100" - 16FJ .083W	2
27.	5000626	Hyd - Tube 16FJ - 108 1/2" - 16FJ	4
28.	4000953	Hyd Cyl - 4x50 63 3/4" Model D	1
	*** 4000907	Hyd. Cyl - 5 x 40 53 3/4" Model C	1
29.	4000916	Hyd Cyl - 6 1/2 x 22 36 1/4"	1
30.	4000917	Hyd Cyl - 5 x 22 37 1/4"	2
31.	4000201	Hyd, O-Ring 1 3/4 - 1 1/2 2-222	4
32.	4000623	Hyd Pilot Chk Valve CKEB - XCN	1
33.	4000921	Hyd Valve Block Sequence CE18D	1
34.	4000924	Hyd Counter Valve CBEA- IHN	1
35.	4000925	Hyd Sequence Valve SCEA -LAN	1
36.	WPH 1 1/4	Washer, Flat - 1 1/4" Hard F - 436	8
37.	NH	Nut, Hex 7/16" Jam Nut - Fine	1
38.	5000736	Hyf-Tee, JIC, 16MJ-16MJ-16FJX	1
39.	5000887	Hose, 16FJX-12C12x26-16MB	1

2 VALVE TANDEM C & D

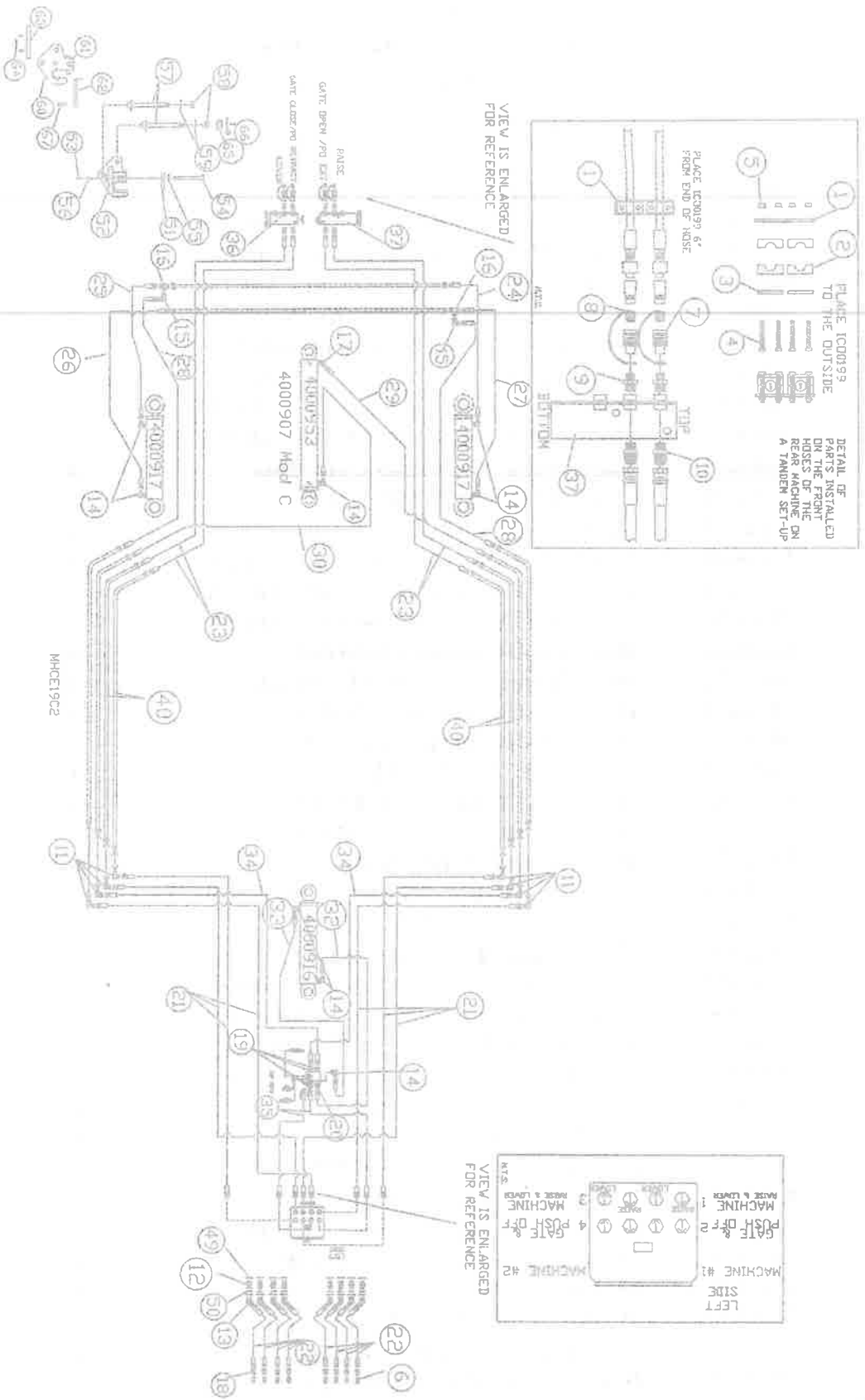

VIEW IS ENLARGED FOR REFERENCE

VIEW IS ENLARGED FOR REFERENCE

MHCET1902

19C 3-VALVE SINGLE
MHCE19C

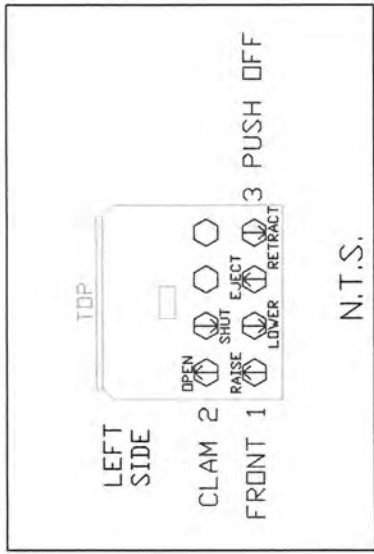

Front

Rear

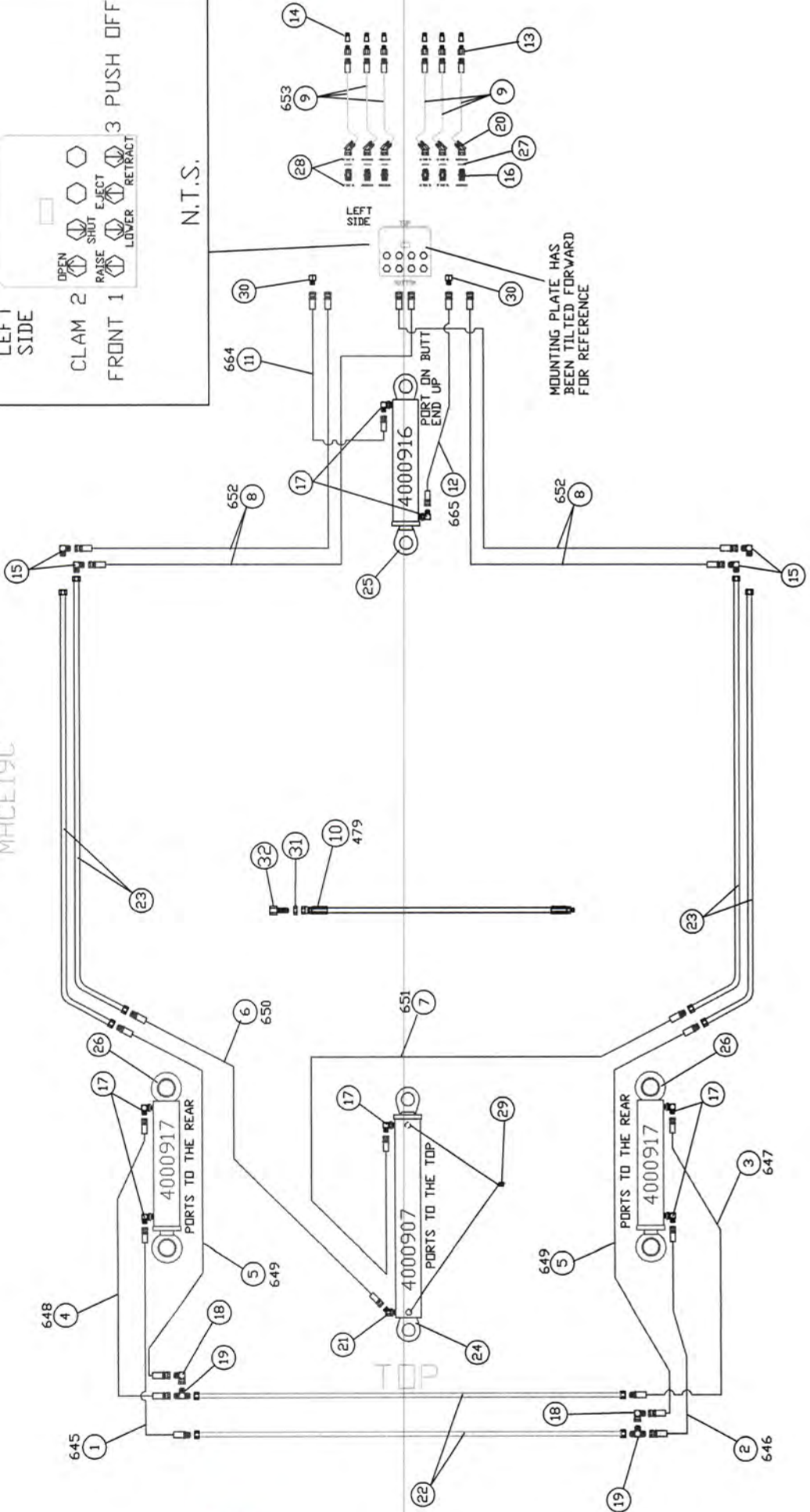

Hydraulics – Series C and D
3 valve single

Ref#	Part#	Description	Qty
1.	5000645	Hose, 12FJX-12C12x46 Cut-16MJ	1
2.	5000646	Hose, 12FJX-12C12x46 Cut-16FJX	1
3.	5000647	Hose, 12FJX-12C12x22 Cut-16MJ	1
4.	5000648	Hose, 12FJX-12C12x22 Cut-16FJX	1
5.	5000649	Hose, 16MJ-12C12x40 Cut-16FJX	2
6.	5000650	Hose, 16MJ-12C12x132 Cut-12FJX	1
7.	5000651	Hose, 16MJ-12C12x172 Cut-12FJX	1
8.	5000652	Hose, 16FJX-12C12x120 Cut-16FJX	4
9.	5000653	Hose, 12MP-12C12x84 Cut-16FJX	6
10.	5000479	Hose, 4FJX-3C1Tx48 CutL-2MP	3
11.	5000664	Hose, 12FJX-12C12x26 Cut-16FJX	1
12.	5000665	Hose, 12FJX-12C12x54 Cut-16FJX	1
13.	5000068	Hyf-Bushing, 8MP-12FP	6
14.	5000089	Hyf-Faster 1/2M Coupler End 2	6
15.	5000620	Hyf-El, JIC-16MJ-16J90	4
16.	5000622	Hyf-Bushing, JIC 16MJ-16MJ	6
17.	5000630	Hyf-El, JIC-12MB-12MJ90	7
18.	5000631	Hyf-El, JIC 12MJ-16FJX90	2
19.	5000633	Hyf-Tee, JIC-16MJT	2
20.	5000640	Hyf-El, JIC 16MJ-16FJX45	6
21.	5000644	Hyf-El, JIC 12MB-12MJ45	1
22.	5000625	Hyd, Tube-16FJ-100" – 16FJ .083W	2
23.	5000626	Hyd, Tube 16FJ-108 ¼" – 16FJ	4
24.	4000953	Hyd Cyl – 4 x 50W (63 ¾") D Model	1
	4000907	5 x 40W (53 ¾") C Model	1
25.	4000916	Hyd Cyl – 6 ½" x 22W (36 ¼")	1
26.	4000917	Hyd Cyl – 5 x 22W (37 ¼")	2
27.	4000201	Hyd, O-ring 1 ¾ 1 ½ 2-222	6
28.	WFH 1 ¼	Washer, Flat, Hard – 1 ¼" F-436	12

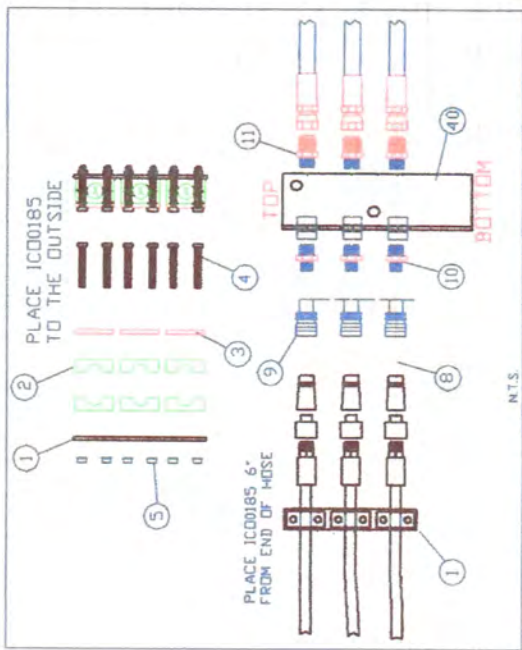

VIEW IS ENLARGED FOR REFERENCE



VIEW IS ENLARGED FOR REFERENCE

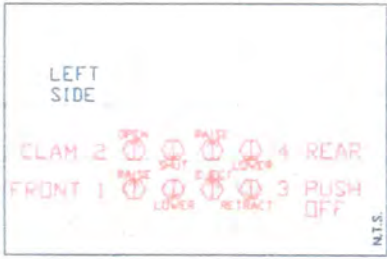

VIEW IS ENLARGED FOR REFERENCE

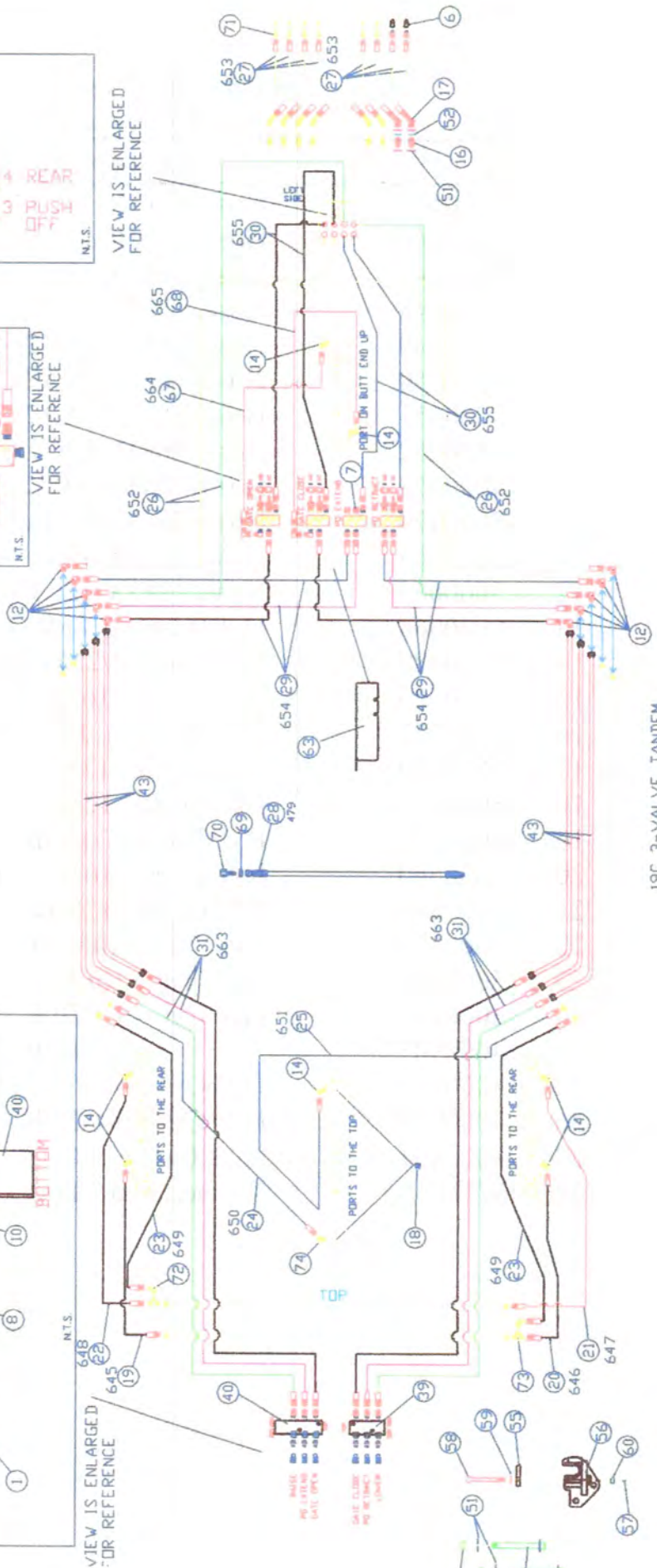

19C 3-VALVE TANDEM
M2000206

19C 3-VALVE TANDEM
M2000206

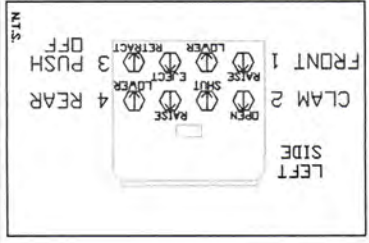
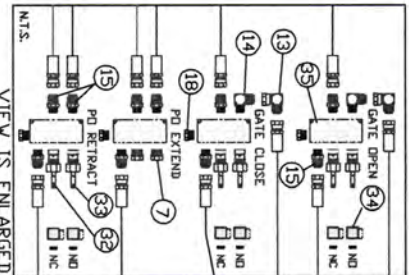
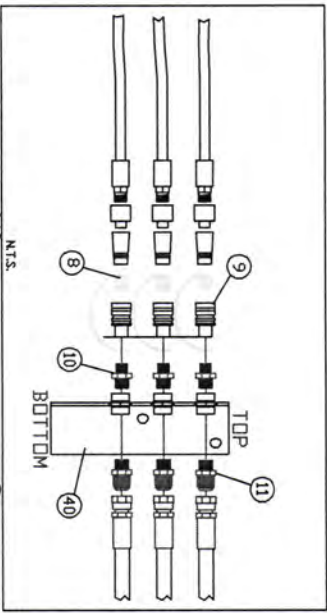
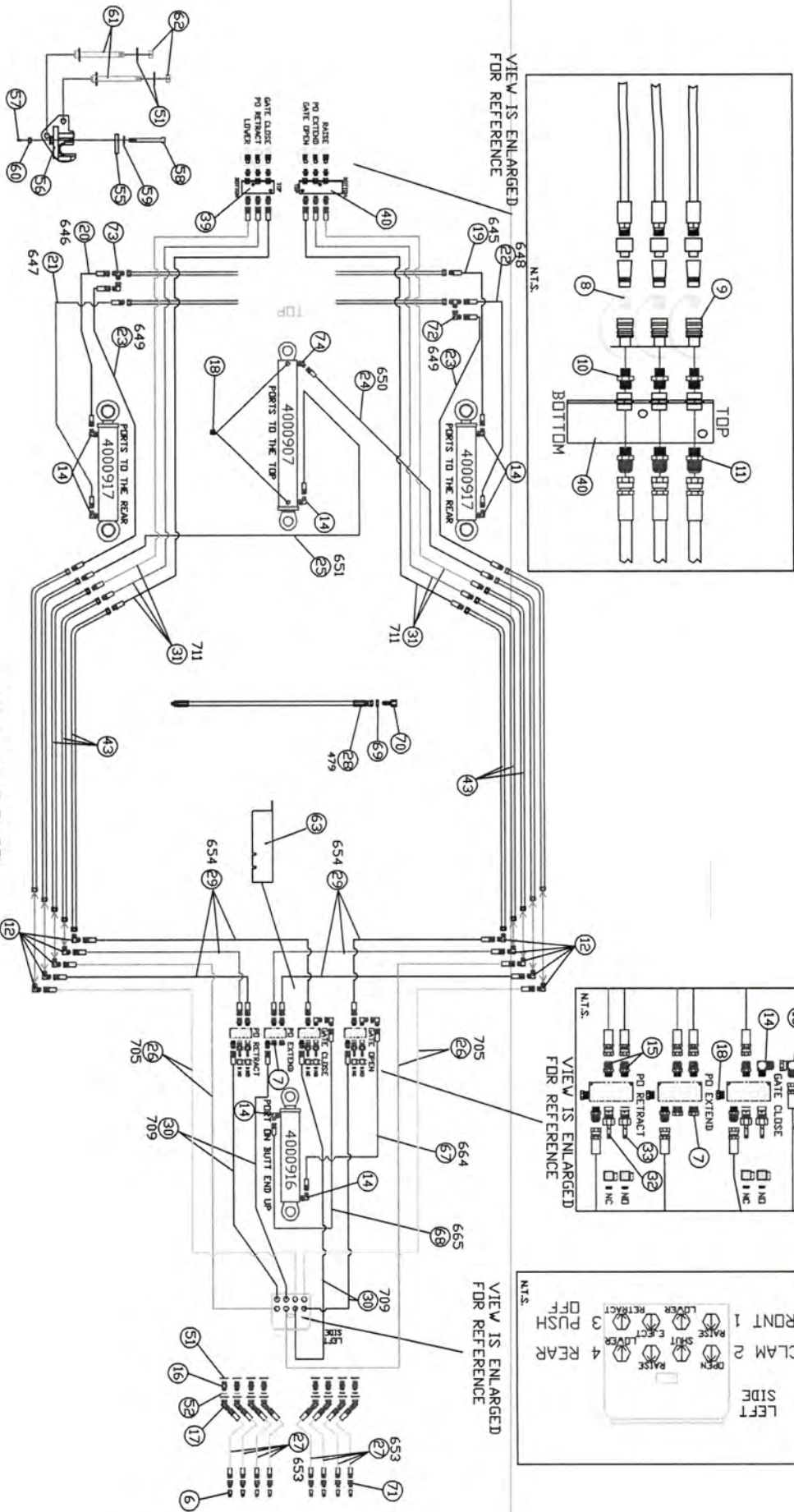

SERIES C & D

(2 – valve) Tandem Hyd.

REF. #	PART #	DESCRIPTION	QTY
1.	ICO0199	CEM Front Hose Clamp 2V	2
2.	5000616	Hose, Clamp Plastic ¾ - 4292SPPH	8
3.	5000618	Hose, Clamp Cover Plate – DPAL4S	6
4.	BH 3/8 x 3	Bolt, Hex – 3/8" x 3" (gr. 5)	8
5.	NW 3/8	Nut, Whiz – 3/8"	12
6.	5000089	Hyf – FASTER ½ M Coupler End 2 (early)	8
	5000835	Hyf – PIONEER 7/8 M END 8010-16P	8
7.	5000385	Hyf – PIONEER ½ Female 4250 – 4	4
	5000845	Hyf – PIONEER ½ Female 4250-15 (new)	4
8.	5000485	Hyf – PIONEER ½ Plug Steel	4
9.	5000521	Hyf – Bushing, 8MP – 12 MP	4
10.	5000656	Hyf – Adap JIC 12MP – 16MJ	4
11.	5000620	Hyf – EL, JIC 16MJ – 16MJ90	8
12.	5000622	Hyf – Bushing, JIC 16MJ – 16MJ	8
13.	5000640	Hyf – EL, JIC 16MJ – 16FJx45	16
14.	5000630	Hyf – EL, JIC 12MB – 12MJ90	8
15.	5000631	Hyf – EL, JIC 16MJ – 16FJx90	2
16.	5000633	Hyf – TEE, JIC 16MJT	2
17.	5000424	Hyf – Plug, 12MB-HH	1
18.	5000836	Hyf – Bushing, 10MB – 12FB	8
19.	5000660	Hyf – Adap JIC 12MB – 16MJ	4
20.	5000698	Hyf – Adap JIC 12MB – 12MJ	1
21.	5000705	HOSE, 16FJX – 12C12x140 Cut – 16FJ	6
22.	5000843	HOSE, 12MB – 12C12x84 Cut – 16FJX	8
23.	5000729	HOSE, 16MJ – 12C12 x192 Cut – 16FJX	4
24.	5000671	HOSE, 12FJX – 12C12x42 Cut – 16MJ	1
25.	5000672	HOSE, 12FJX – 12C12x42 Cut – 16FJX	1
26.	5000673	HOSE, 12FJX – 12C12x34 Cut – 16MJ	1
27.	5000674	HOSE, 12FJX – 12C12x34 Cut – 16FJX	1
28.	5000675	HOSE, 12C12MGS/16MJ/16FJX 39.5"	2
29.	5000678	HOSE, 12FJX-12C12x108 Cut – 16MJ	1
30.	5000680	HOSE, 12FJX-12C12x128 Cut-16MJ	1
31.	5000479	HOSE, 4FJX – 3C1Tx52 Cut – 2MP	2
	5000710	HOSE, 4FJX – 3CITx56 Cut – 2MP	1
32.	5000664	HOSE, 12FJX – 12C12x41 Cut – 12FJX	1
33.	5000665	HOSE 12FJX – 12C12 x67 Cut – 12FJX	1
34.	5000654	HOSE, 16FJX – 12C12x79Cut – 16FJX	2
35.	5000709	HOSE, 16FJX – 12C12 x52Cut – 16FJX	2
36.	ICO0238	19C 18D Hyd Coupler Plate Right side	1
37.	ICO0245	19C 18D Hyd Coupler Plate Left side	1
	ICO0446	Coupler Plate (RT) New	1
	ICO0447	Coupler Plate (LF) New	1
	5000844	Coupler (16MJIC-8MB) welds into plate	6
	5000918	O-Ring for coupler 5000844	6
38.	BH 5/8 x 2 ½	Bolt, Hex – 5/8 x 2 ½" (gr 8)	4
39.	NL 5/8	Nut, Nyloc – 5/8 x 2 ½" (gr 8)	4

**SERIES C & D Tandem Hyd
(2 – valve)**

REF#	PART #	DESCRIPTION	QTY
40.	5000626	Hyd, Tube 16FJ – 108 ¼” – 16FJ	4
41.	ICO0224	19C 18D #2 Side Pipe Clamp	2
42.	ICO0226	19C 18D #2 Rear Side Pipe Clamp	2
43.	BH ½ x 3	Bolt, Hex – ½ x 3” (gr 5)	4
44.	WFH ½	Washer, Flat, Hard ½” F-436	4
45.	NL ½	Nut, Nyloc – 1/2 “ (gr 2)	24
46.	ICO0228	19C 18D Clamp, Hyd Line 2x5 ¼”	12
47.	BH ½ x 3 ½	Bolt, Hex – ½ x 3 ½” (gr 5)	8
48.	BH ½ x 2 ½	Bolt, Hex – ½ x 2 ½” (gr 5)	8
49.	WFH 1 ¼	Washer, Flat, Hard 1 ¼” F-436	8
50.	4000201	Hyd, O – Ring 1 ¼ - 1 ½” 2-222	4
51.	ICO0122	Quick Attach Clamp	1
52.	ICO0246	Quick Attach Tandem Hitch (series 1)	1
53.	PR	Roll Pin ¼ x 1”	2
54.	BH	Bolt, Hex 1 x 9”	2
55.	WFH	Washer, Flat, Hard 1”	2
56.	NSQ	Nut, Square 1”	2
57.	ICO0247	Quick Attach Hitch Bolts	2
58.	NJ	Nut, Jam 1 ½”	2
59.	WFH	Washer, Flat, Hard 1 ½”	2
60.	ICO0375	Quick Attach Tandem Hitch (series 2)	1
61.	ICO0368	Lockdown Ears.	1
62.	ICO0369	Lockdown Pin	1
63.	ICO0370	Pivot Pin	1
64.	PC	Pin, Cotter 3/16 x 2”	2
65.	NC	Nut, Castle 1 ½”	2
66.	PC	Pin, Cotter 3/16 x 3 ½”	2
67.	SP	Spring Lock Pin	

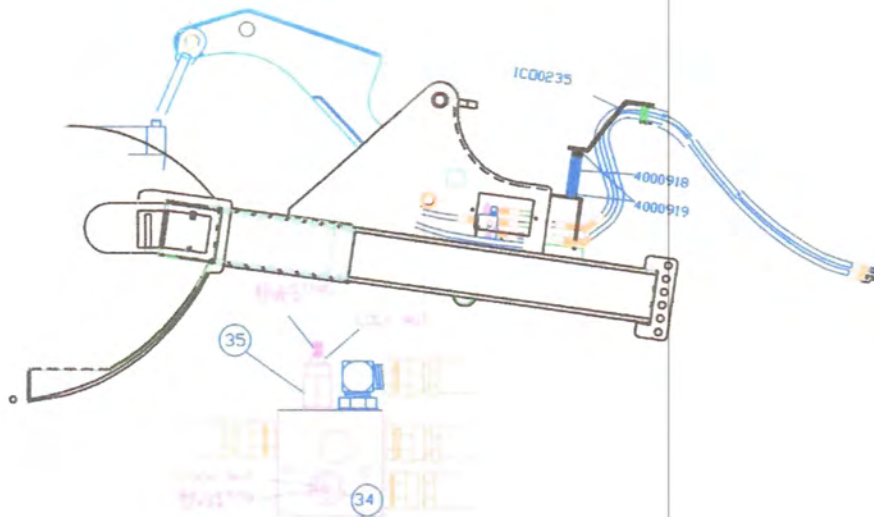

Valve Adjustment

Problem:

Push wall comes forward before gate is fully up.

Answer:

- *Loosen locknut on top of valve
- *Adjust sequence valve 1/4 turn clockwise and check performance.
- *Repeat until remedied
- *Retighten locknut

Problem:

Gate comes down before push wall is fully back.

Answer:

- *Adjust counterbalance valve (located on side of valve block in tongue)
- *Loosen locknut on top of valve
- *Adjust counterbalance valve 1/4 turn counterclockwise and check performance.
- *Repeat until remedied
- *Retighten locknut.

2 Valve Earthmover Hydraulics

Below are the components used to assemble the 2 valve system.

*M-1520
Ø R106 KIT
for 4-623
4-924
4-925*

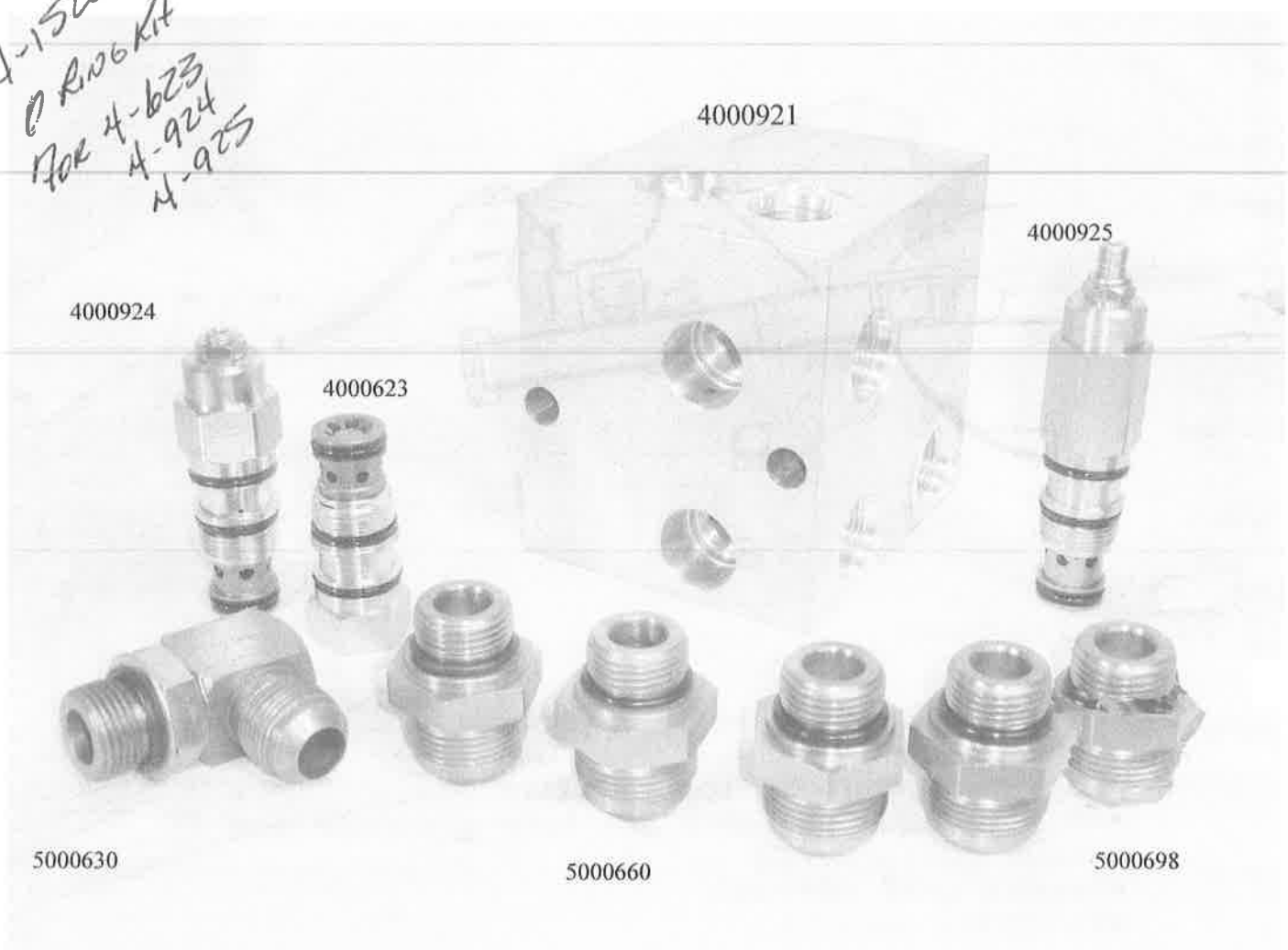

Hose Hookup

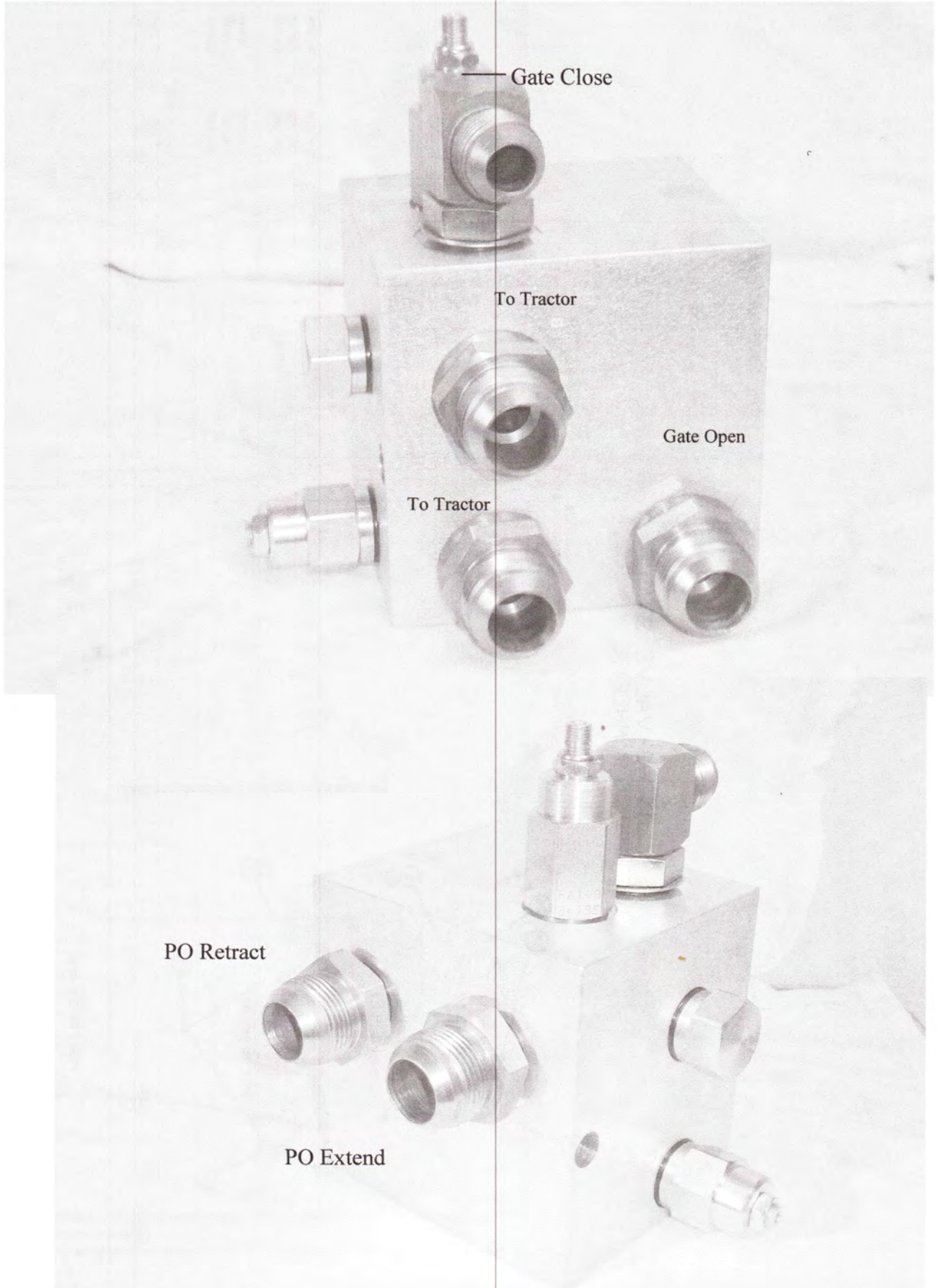

19C 3-VALVE SINGLE
MHCE19C

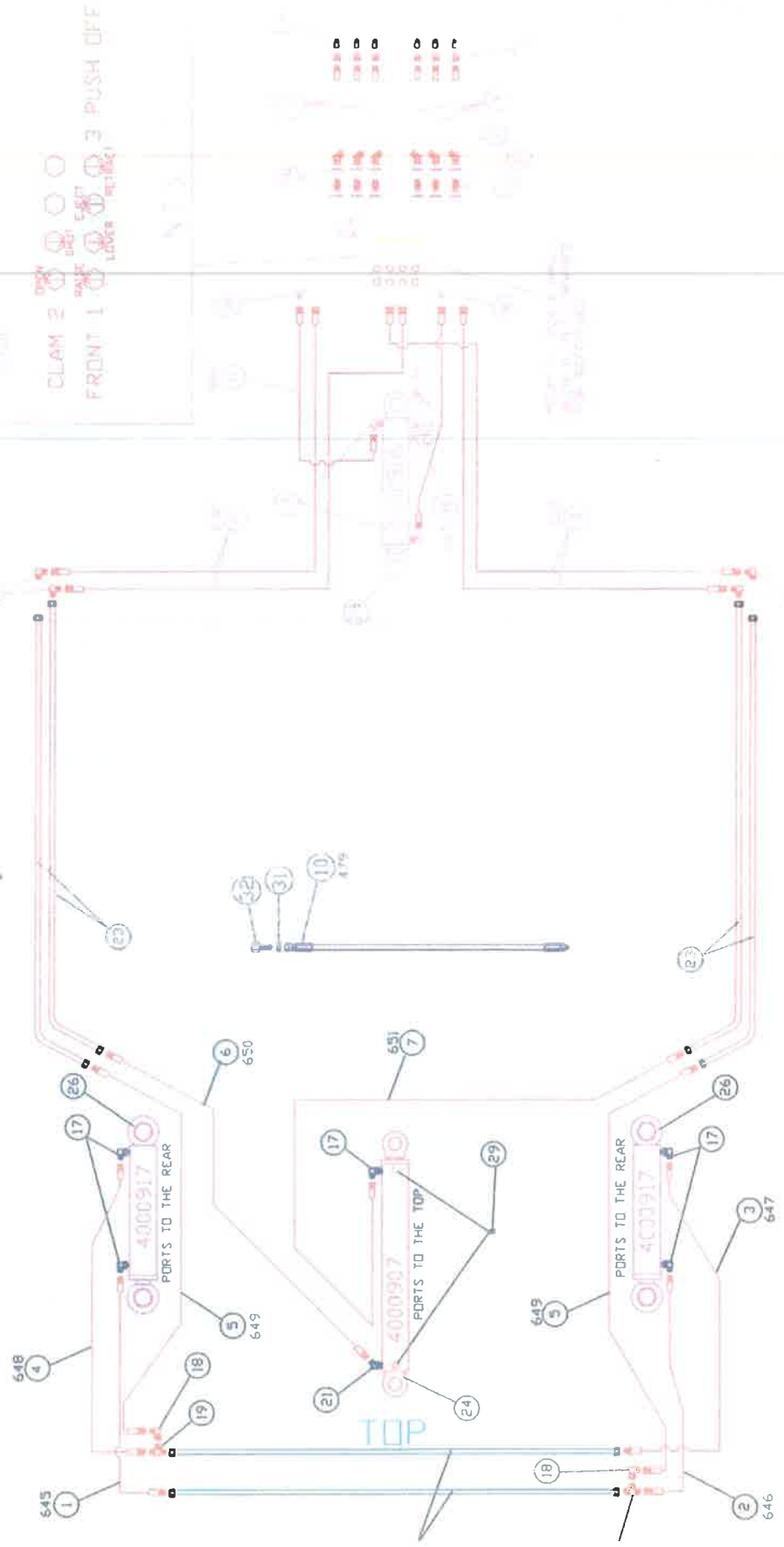

SERIES C & D
OPTIONAL TANDEM HYDRAULIC PARTS LIST
 (3 - Valve) After 4041A & 4531A

M2000335

REF. #	PART #	DESCRIPTION	QTY.
1.	ICO0185	FRONT HOSE CLAMP	2
2.	5000616	HOSE CLAMP, PLASTIC ¾	8
3.	5000618	HOSE CLAMP COVER PLATE	6
4.	BH 3/8 x 3	BOLT, HEX (GR 5) 3/8" x 3"	12
5.	NW 3/8	NUT, WHIZ	12
6.	5000089	HYF - FASTER ½ M COUPLER	2
7.	5000441	HYF - PLUG 16MB	4
8.	5000485	HYF - PIONEER ½ PLUG STEEL	6
9.	5000385	HYF - PIONEER ½ FEMALE	6
10.	5000521	HYF - BUSHING, 8MP - 12MP	6
11.	5000656	HYF - ADA JIC 12MP - 16MJ	6
12.	5000620	HYF - EL, JIC 16MJ - 16MJ90	6
13.	5000643	HYF - EL, JIC 12MJ - 12FJX90	2
14.	5000630	HYF - EL, JIC 12MB - 12MJ90	2
15.	5000660	HYF - ADAP JIC 12MB - 16MJ	10
16.	5000622	HYF - BUSHING, JIC 16MJ - 16MJ	2
17.	5000640	HYF - EL, JIC 16MJ - 16FJX45	2
18.	5000424	HYF - PLUG, 12MB - HH PLUG	4
19.	5000645	HOSE, 12FJX - 12C12x46 CUT - 16MJ	1
20.	5000646	HOSE, 12FJX - 12C12x46 CUT - 16FJX	1
21.	5000647	HOSE, 12FJX - 12C12x22 CUT - 16MJ	1
22.	5000648	HOSE, 12FJX - 12C12x22 CUT - 16FJX	1
23.	5000649	HOSE, 16MJ - 12C12x66 CUT - 16FJX	2
24.	5000650	HOSE, 16MJ - 12C12x156 CUT - 12FJX	1
25.	5000651	HOSE, 16MJ - 12C12x200 CUT - 12FJX	1
26.	5000705	HOSE, 16FJX - 12C12x136 CUT - 16FJX	4
27.	5000653	HOSE, 12MP - 12C12x84 CUT - 16FJX	8
28.	5000479	HOSE, 4FJX - 3C1Tx48 CUTL - 2MP	4
29.	5000654	HOSE, 16FJX - 12C12x79 CUT - 16FJX	6
30.	5000709	HOSE, 16FJX - 12C12x52 CUT - 16FJX	4
31.	5000711	HOSE, 16MJ - 12C12x232 CUT - 16FJX	6
32.	4000647	HYD. VALVE ELEC (GS068300N) NC	3
33.	4000648	HYD. VALVE ELEC (GS068800) NO	3
34.	LT0023	HYD. VALVE ELEC CELL(CCPO12L)	6
35.	4000639	HYD. VALVE BLOCK	4
36.	ICO0155	WIRE HARNESS CE TANDEM (REAR)	1

M2000335

SERIES C & D

OPTIONAL TANDEM HYDRAULIC PARTS LIST

(3 - Valve)

REF. #	PART #	DESCRIPTION	QTY
37.	4000057	OPTION, CE TAND SWITCH 98+	1
38.	4000652	OPTION, CE TAND SWITCH BOX 97-	1
39.	ICO0238	18D - 19C HYD COUPLER PLATE (RT)	1
40.	ICO0245	18D - 19C HYD COUPLER PLATE (LF)	1
	ICO0446	Coupler Plate (RT) new	
	ICO0447	Coupler Plate (LF) new	
	5000844	Coupler (8MB-16MJIC) weld into plates	6
41.	BH 5/8 x 2 1/2	BOLT, HEX (GR 8) 5/8" x 2 1/2"	4
42.	NL 5/8	NUT, NYLOC (GR 5) 5/8"	4
43.	5000626	HYD, TUBE 16FJ - 108 1/4 - 16FJ	6
44.	ICO0223	18D #5 SIDE PIPE CLAMP	2
45.	IOC0225	18D #5 REAR SIDE PIPE CLAMP	2
46.	BH 1/2 x 3	BOLT, HEX (GR 5) 1/2" x 3"	4
47.	WFH 1/2	WASHER, FLAT, HARD 1/2"	4
48.	NL 1/2	NUT, NYLOC (GR 2) 1/2"	4
49.	ICO0228	18D CLAMP, HYD, LINE (2 x 5 1/4)	4
50.	BH 1/2 x 3 1/2	BOLT, HEX (GR 5) 1/2" x 3 1/2"	8
51.	WFH 1 1/4	WASHER, FLAT, HARD 1 1/4"	8
52.	4000201	HYD. O-RING 1 3/4 - 1 1/2 2-222	2
53.	LT0004	LIGHTS, TANDEM PLUG EXT.	1
54.	LT0005	LIGHTS, TANDEM EXT. W/7P	1
55.	ICO0122	CE QUICK ATTACH CLAMP	1
56.	ICO0246	18D - 19C QUICK ATT. HITCH TAN.	1
57.	PR 1/4 x 1	PIN, ROLL SP-250-1000 1/4" x 1"	2
58.	BH 1 x 9	BOLT, HEX (GR 8) 1" x 9"	2
59.	WFH 1	WASHER, FLAT, HARD 1"	2
60.	NSQ 1"	NUT, SQUARE (GR 8) 1"	2
61.	ICO0247	QUICK ATTACH HITCH BOLTS	2
62.	NJ 1 1/2	NUT, JAM (GR 5) 1 1/2"	2
63.	ICO0248	18D - 19C HYD. SHIELD	1
64.	WF 1/2	WASHER, FLAT 1/2"	2
65.	NW 1/2	NUT, WHIZ 1/2"	2
66.	BH 3/8 x 5	BOLT, HEX (GR 5) 3/8" x 5"	4
67.	5000664	HOSE, 12FJX - 12C12x34 CUT - 12FJX	1
68.	5000665	HOSE, 12FJX - 12C12x62 CUT - 12FJX	1
69.	ICO0375	QUICK ATT. TAN. HITCH (series 2)	1
70.	ICO0369	LOCKDOWN PIN (series 2, tan hitch)	1
71.	SP	Spring Lock Pin	1

Below are the components of the hyd. Valve block assembly, used on 3 valve tandem units.

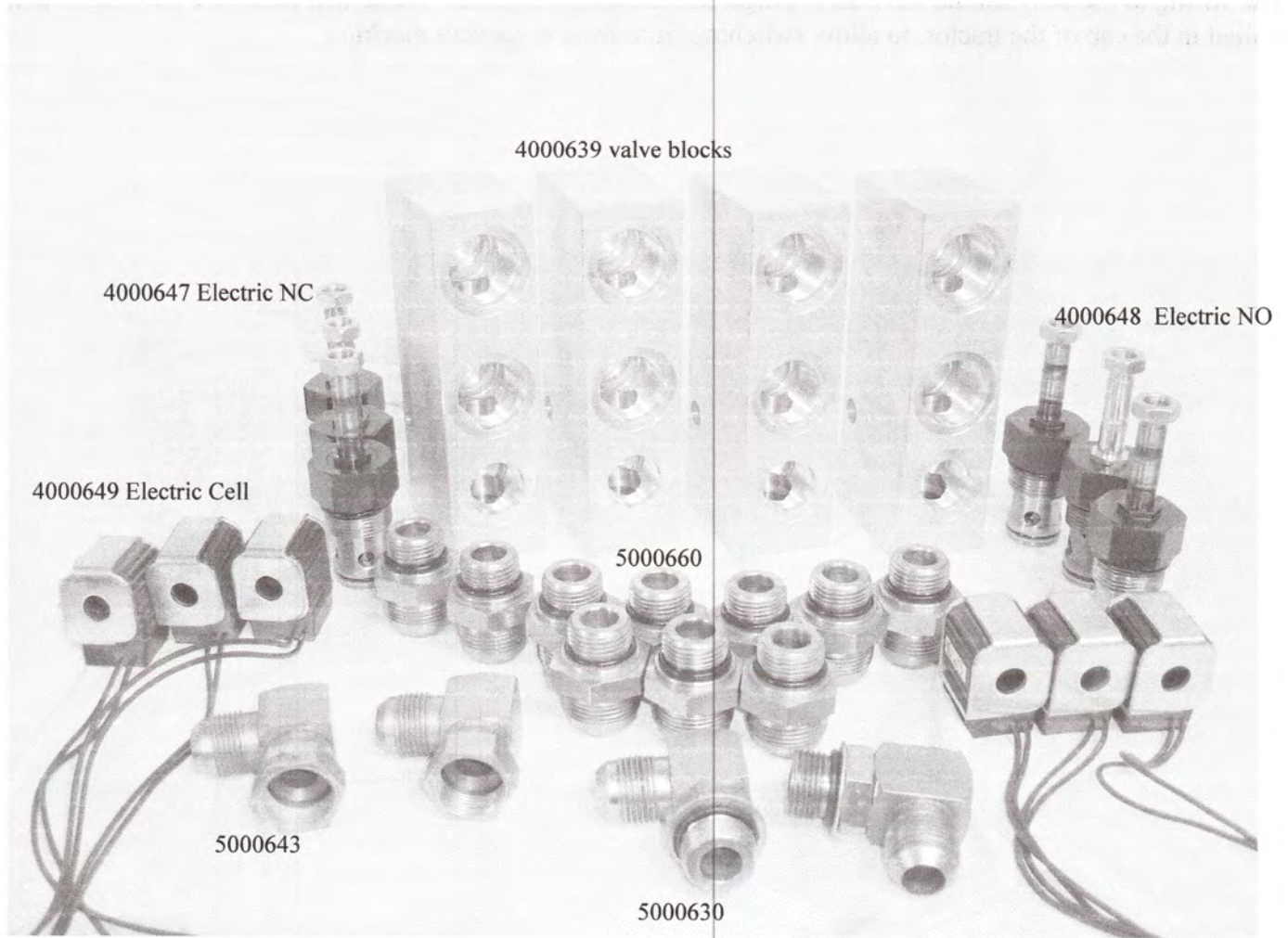

Valve blocks shown assembled
(From Front)

(From Back)

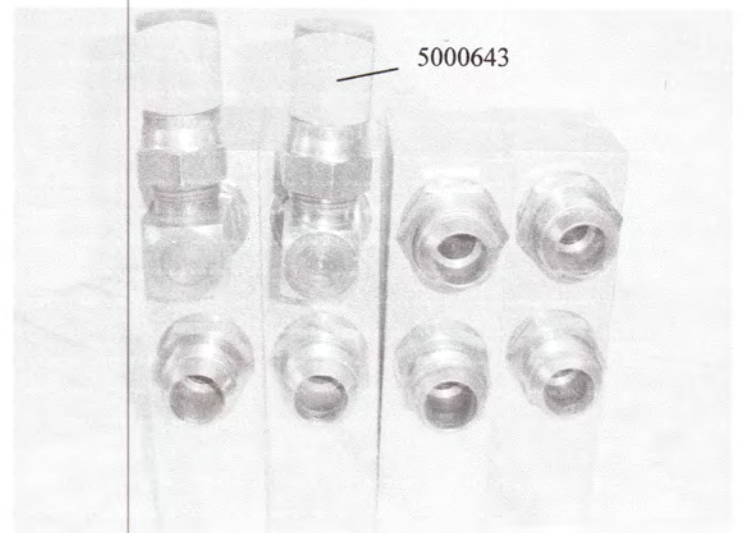
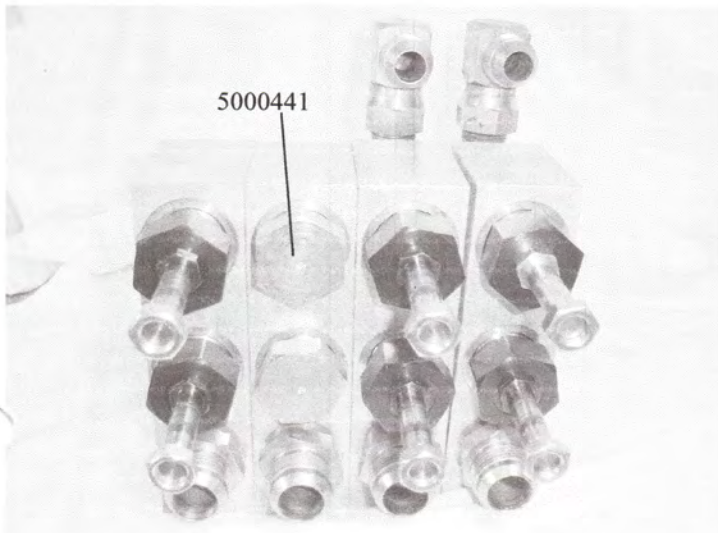

Shown below are the fully assembled blocks, with the electric cells installed (shown from the front)

The wiring to the cells should have all (+) together, and all (-) together. These will then wire into the switch that is installed in the cab of the tractor, to allow switching from front to tandem machine.



ICON IND.

Hydraulic hookup, shown from the front of the Earthmover (toward the tractor)

Gate Open (Connect to the front
end of the gate cylinder)

Gate Close (Connect to the rear
of the gate cylinder)

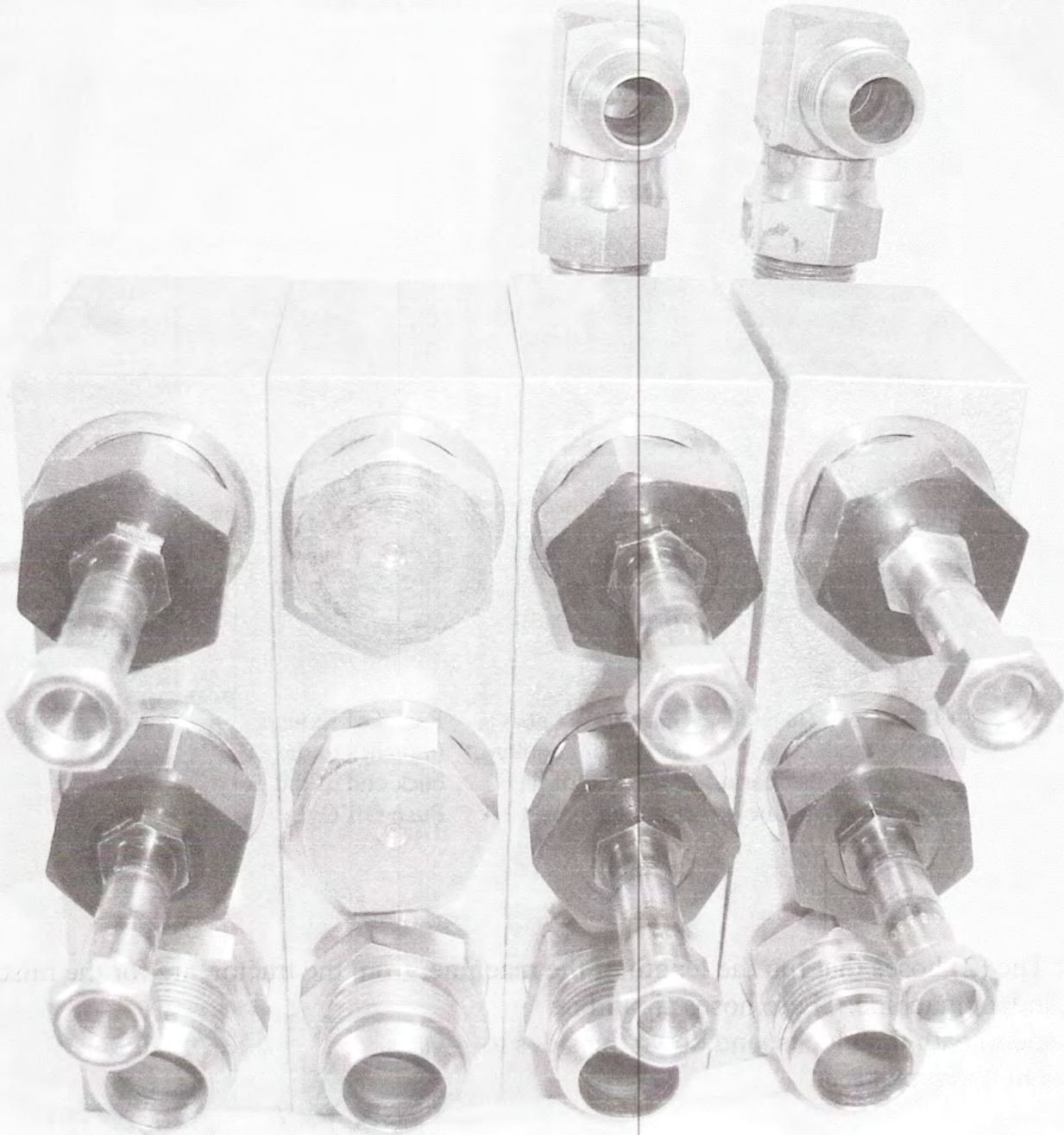

Push Off (Retract)

Push Off (Extend)

Gate (Close)

Gate (Open)

Hydraulic Hookup

ICON IND.

(shown from the back—toward scraper)



Gate Open (located at the tandem hookup at the rear of the front machine)

Gate Close (also at the tandem hookup, at the rear of the front machine)

Push Off Extend (routes to the tandem hookup at the rear of the front machine)

Push Off Retract, also runs to the tandem hookup at the rear of the front machine.

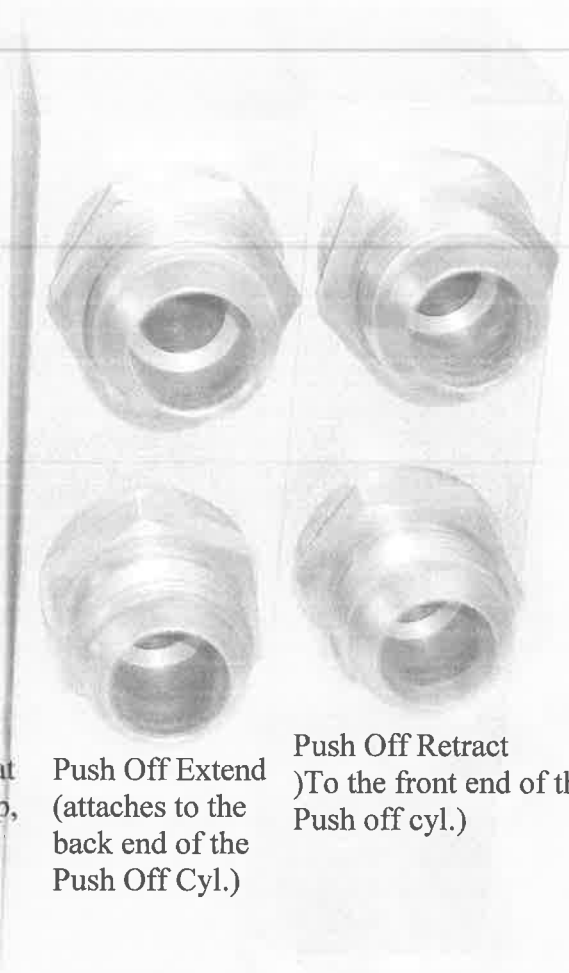

Push Off Extend (attaches to the back end of the Push Off Cyl.)

Push Off Retract (To the front end of the Push off cyl.)

NOTE: The (2) hoses that run the length of the machine, from the tractor, are for the raise/lower of the tandem machine. These hoses should be routed underneath the blocks, and down the sides to the tandem hookup at rear.

Shown at right is the tandem hookup at the rear of the front machine.

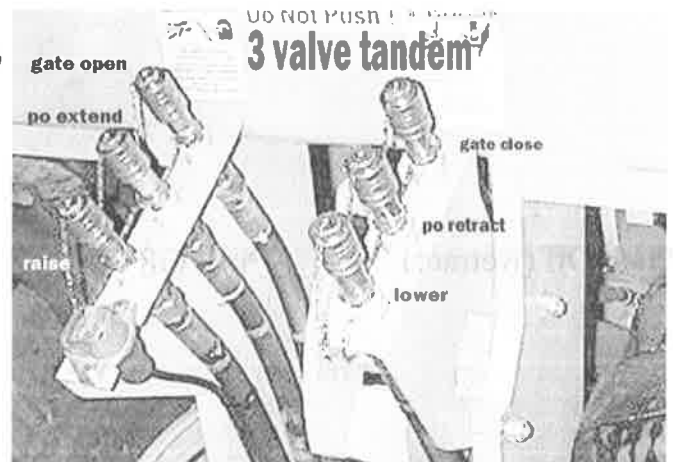

Seal Kits and Cylinder Part Numbers For C & D Series

Cyl.	Location	WO/Bushing	W/Bushing
6 1/2" x 22	Gate	4000916	4001034
5" x 40"	Eject on C	4000907	4001035
4" x 50"	Eject on D	4000953	4001036
5" x 22"	Lift	4000917	4001037

Seal Kits

4"	4000964
5"	4000961
6"	4001434
6.5"	4000962

New Cyl #
H-1034

Seal Kit and Component List

4000916 6.5" Bore/3.00" Rod
6.5" x 22" Cylinder
ICDN Seal Kit # 4000962 Will Contain #'s (8 thru 21)
All Other Parts Special Order

Ref#	Qty	Part#	Description	Size
1.	1	4001018	Case Weldment	6.5"
2.	1	4001017	Rod Weldment	3"
3.	1	4001016	Thread Ring	6.5"
4.	1	4001015	Head Gland	6.5"
5.	1	4001014	Piston	6.5"
6.	1	4001013	Nut	6.5"
7.	2	4000988	Set Screw	#10-32UNF
8.	1	4000984	O-Ring	5.50ID x 1/8CS
9.	1	4000983	O-Ring	6.50ID x 3/32CS
10.	1	4000976	Nylon Plug	.31 Dia. x .25LG
11.	1	4000982	Back Up	6.38OD x 3/16CS
12.	1	4000981	O-Ring	6.38OD x 3/16CS
13.	1	4000980	Teflon Seal	6.50OD
14.	2	4000979	Wear Ring	6.50OD x .63LG
15.	2	4000971	Back Up	3.00ID x 1/8CS
16.	1	4000970	O-Ring	3.00ID x 1/8CS
17.	1	4000969	Wear Ring	3.00ID x .98LG
18.	1	4000968	Buffer Seal	3.00ID
19.	1	4000967	U - Cap	3.00ID
20.	1	4000966	Back Up	3.00 x .13LG
21.	1	4000965	Wiper, Lip Type	3.00ID

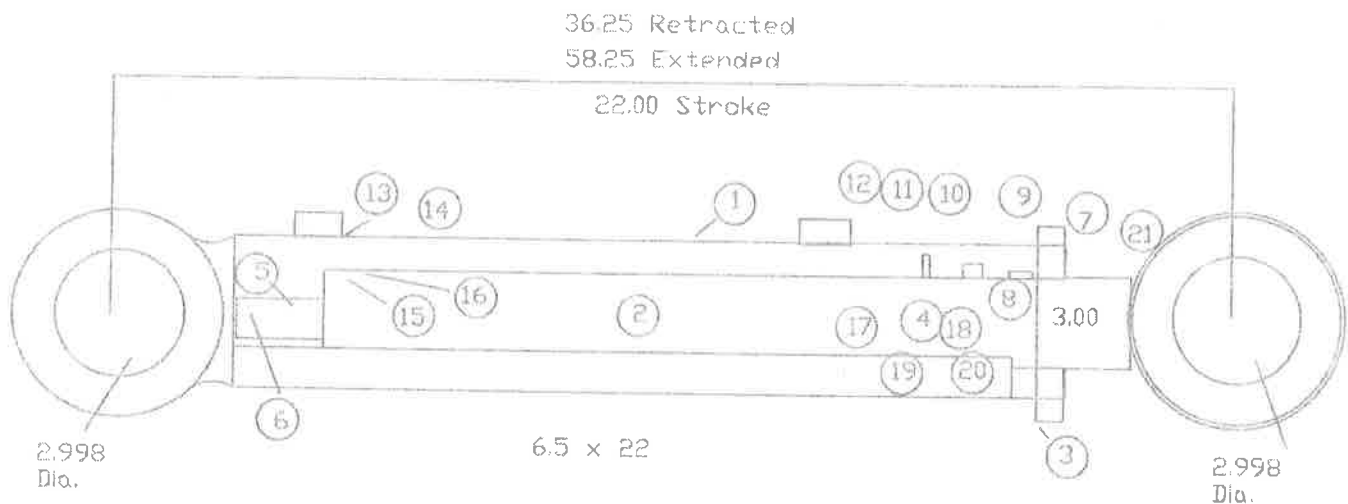

Seal Kit and Component List

#4000917 5.00" Bore/3.00" Rod
 5 x 22" Cylinder (Machined for spherical bearings)
 ICON Seal Kit #4000961 Will Contain #'s (8 thru 21)
 All Other Parts Special Order

Ref#	Qty	Part#	Description	Size
1.	1	4001004	Case Weldment	5"
2.	1	4001003	Rod Weldment	3"
3.	1	4001002	Thread Ring	5"
4.	1	4001001	Head Gland	5"
5.	1	4001000	Piston	5"
6.	1	4000999	Nut	5"
7.	2	4000998	Set Screw	#10-32UNF
8.	1	4000978	□-Ring	4.25ID x 1/8CS
9.	1	4000977	□-Ring	5.00ID x 3/32CS
10.	1	4000976	Nylon Plug	.31 Dia. x .25LG
11.	1	4000975	Back Up	5.00OD x 3/16CS
12.	1	4000974	□-Ring	5.00OD x 3/16CS
13.	1	4000973	Teflon Seal	5.00OD
14.	2	4000972	Wear Ring	5.00OD x .63LG
15.	2	4000971	Back Up	3.00ID x 1/8CS
16.	1	4000970	□-Ring	3.00ID x 1/8CS
17.	1	4000969	Wear Ring	3.00ID x .98LG
18.	1	4000968	Buffer Seal	3.00ID
19.	1	4000967	U - Cap	3.00ID
20.	1	4000966	Back Up	3.00 x .13LG
21.	1	4000965	Wiper, Lip Type	3.00ID

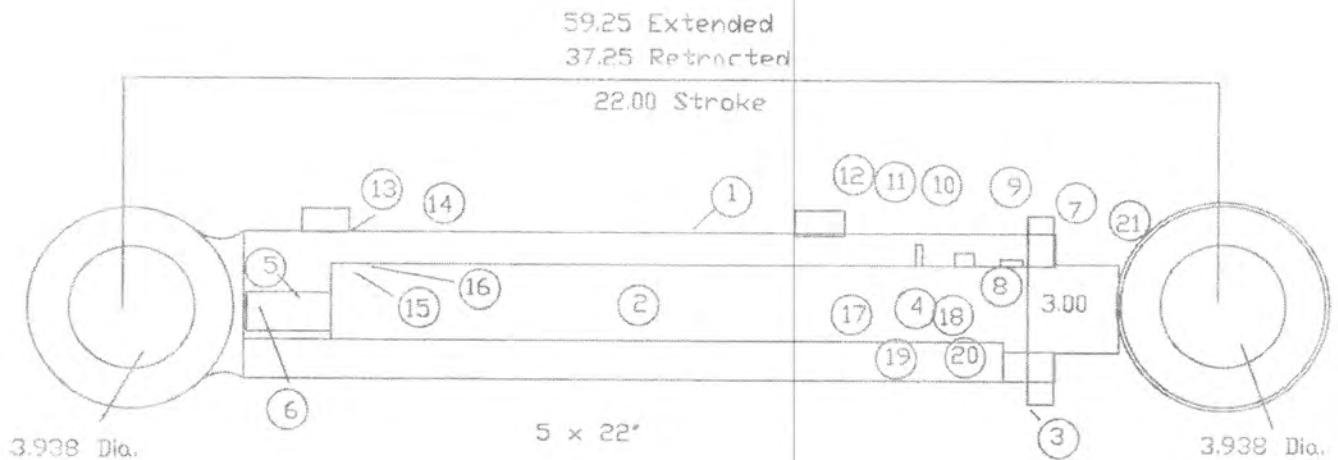

Seal Kit and Component List

#4000953 4.00" Bore/2.50" Rod
 4 x 50" Cylinder (Used on D Models)

ICCN Seal Kit #4000964 Will Contain #'s (8 thru 21)
 All Other Parts Special Order

Ref#	Qty	Part#	Description	Size
1.	1	4001012	Case Weldment	4"
2.	1	4001011	Rod Weldment	2.50"
3.	1	4001010	Thread Ring	4"
4.	1	4001009	Head Gland	4"
5.	1	4001008	Piston	4"
6.	1	4001007	Nut	4"
7.	2	4000998	Set Screw	#10-32UNF
8.	1	4000997	O-Ring	3.50ID
9.	1	4000996	O-Ring	4.00ID x 3/32CS
10.	1	4000976	Nylon Plug	.31 Dia. x .25LG
11.	1	4000995	Back Up	4.00OD
12.	1	4000994	O-Ring	4.00OD
13.	1	4000993	Teflon Seal	4.00OD
14.	2	4000992	Wear Ring	4.00OD x .63LG
15.	2	4000991	O-Ring	2.50ID
16.	1	4000990	Back Up	2.50ID
17.	1	4000989	Wear Ring	2.50ID x .98LG
18.	1	4000988	Buffer Seal	2.50ID
19.	1	4000987	U - Cap	2.50ID
20.	1	4000986	Back Up	2.50 x .13LG
21.	1	4000985	Wiper, Lip Type	2.50ID

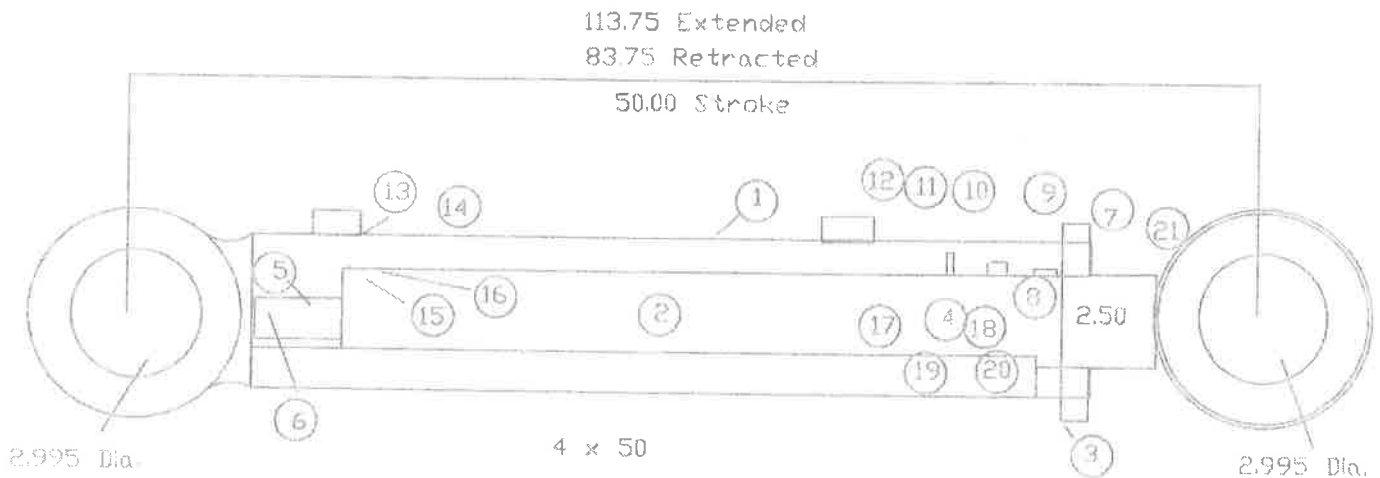

4001035 NEW Bilks 5x40

Seal Kit and Component List

#4000953 4.00" Bore/2.50" Rod
4 x 50" Cylinder (Used on D Models)

ICDN Seal Kit #4000964 Will Contain #'s (8 thru 21)
All Other Parts Special Order

Ref#	Qty	Part#	Description	Size
1.	1	4001012	Case Weldment	4"
2.	1	4001011	Rod Weldment	2.50"
3.	1	4001010	Thread Ring	4"
4.	1	4001009	Head Gland	4"
5.	1	4001008	Piston	4"
6.	1	4001007	Nut	4"
7.	2	4000998	Set Screw	#10-32UNF
8.	1	4000997	O-Ring	3.50ID
9.	1	4000996	O-Ring	4.00ID x 3/32CS
10.	1	4000976	Nylon Plug	.31 Dia. x .25LG
11.	1	4000995	Back Up	4.00OD
12.	1	4000994	O-Ring	4.00OD
13.	1	4000993	Teflon Seal	4.00OD
14.	2	4000992	Wear Ring	4.00OD x .63LG
15.	2	4000991	O-Ring	2.50ID
16.	1	4000990	Back Up	2.50ID
17.	1	4000989	Wear Ring	2.50ID x .98LG
18.	1	4000988	Buffer Seal	2.50ID
19.	1	4000987	U - Cap	2.50ID
20.	1	4000986	Back Up	2.50 x .13LG
21.	1	4000985	Wiper, Lip Type	2.50ID

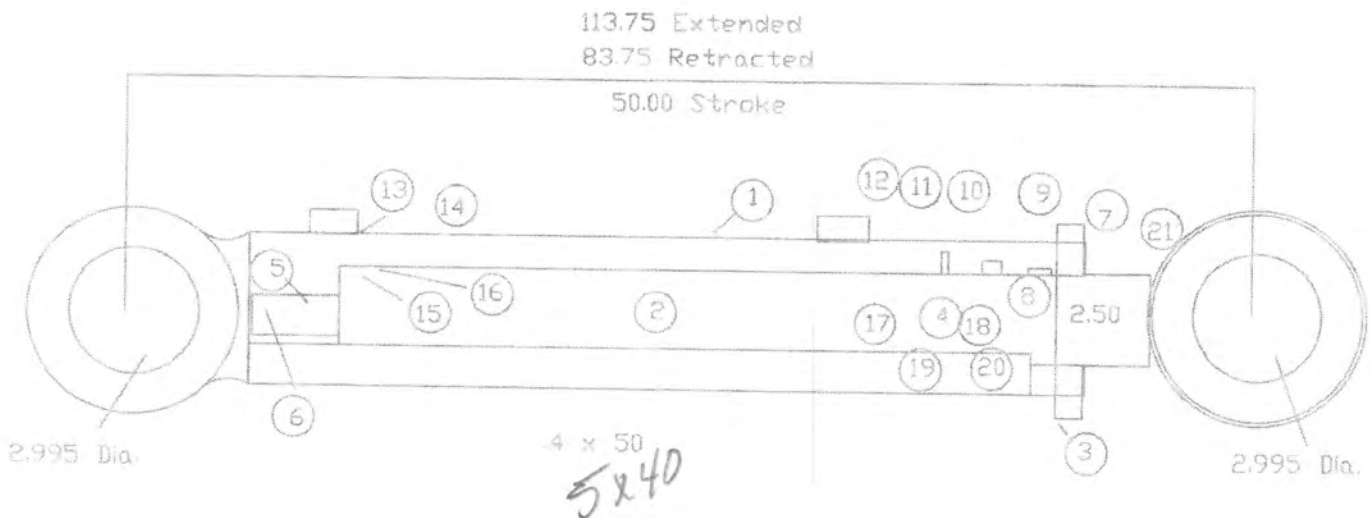

ICON and CAT Crossover Part #'s For 5x22/5x40 KAYDON Cyl's

Ref #	Description	Size	ICON #	CAT #
11.	Back Up	5.00ODx3/16 CS	4000975	9X7279
12.	O-Ring	5.00ODx3/16 CS	4000974	5P4326
13.	Teflon Seal	5.00OD	4000973	5J5020
14.	Wear Ring	5.00ODx.63 LG	4000972	660 BRZ
15.	Back Up	3.00IDx1/8 CS	4000971	8J2574
16.	O-Ring	3.00IDx1/8 CS	4000970	1H7339
17.	Wear Ring	3.00IDx.98 LG	4000969	8C9161
18.	Buffer Seal	3.00ID	4000968	8C9126
19.	U-Cup	3.00ID	4000967	5J8300
21.	Wiper, Lip Type	3.00ID	4000965	3E4170

ICON and CAT Crossover Part #'s For 4 x 50 KAYDON Cyl's

Ref#	Description	Size	ICON #	CAT #
11:	Back Up	4.00OD	4000995	2K6830
12.	O-Ring	4.00OD	4000994	1H8128
13.	Teflon Ring	4.00OD	4000993	5J5402
14.	Wear Ring	4.00 x .63LG	4000992	660 BRZ
15.	O-Ring	2.50ID	4000991	1H5728
16.	Back Up	2.50ID	4000990	4J9225
17.	Wear Ring	2.50ID x .98LG	4000989	8T0785
18.	Buffer Seal	2.50ID	4000988	8C3839
19.	U-Cup	2.50ID	4000987	5J0964
21.	Wiper, Lip Type	2.50ID	4000985	3E4166

ICON and CAT Crossover Part #'s For 6.5 x 22 KAYDON Cyl's

Ref#	Description	Size	ICON #	CAT #
11.	Back Up	6.38OD x 3/16CS	4000982	7J8956
12.	O-Ring	6.38OD x 3/16CS	4000981	7J8955
13.	Teflon Seal	6.50OD	4000980	5J4991
14.	Wear Ring	6.50OD x .63LG	4000979	660BRZ
15.	Back Up	3.00ID x 1/8CS	4000971	8J2574
16.	O-Ring	3.00ID x 1/8CS	4000970	1H7339
17.	Wear Ring	3.00ID x .98LG	4000969	8C9161
18.	Buffer Seal	3.00ID	4000968	8C9126
19.	U-Cup	3.00ID	4000967	5J8300
21.	Wiper, Lip Type	3.00ID	4000965	3E4170

Adjustment Of The Axle Bearings

The initial adjustment should be made by the Dealer, during the 24 to 36 hours service. Following this adjustment, the bearings should be checked app. every 30 days of use.

The tires should be hydraulically raised off the ground, to allow for free turning of the wheels

The axle nut lock washer tabs should be straightened, to allow turning of the adjustment nuts.

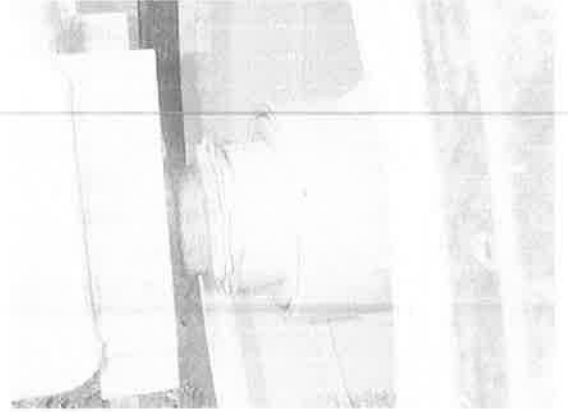

Using the wrench (shown) that is attached to the left side of each machine. Loosen the outer lock nut, to allow the inner adjustment nut to turn.

Tighten the inner nut until the bearing seats firmly into the race, then back the nut off 1/4 of a turn.

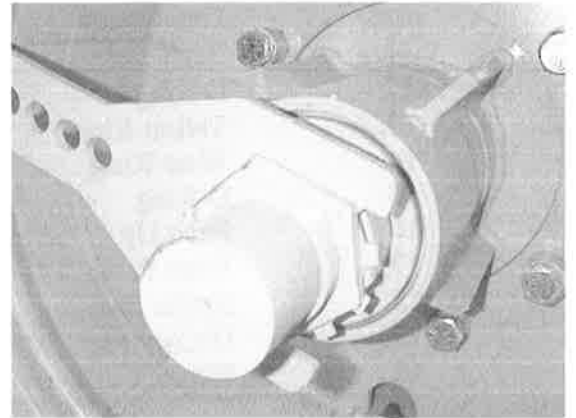

Once the proper seating is reached, the outer nut should be tightened firmly, to prevent the inner nut from loosening.

(Be certain that the inner nut does not turn while tightening the outer nut, as this will also tighten the bearing).

Be sure to bend the tabs back down on the nuts to assure they do not turn during use.

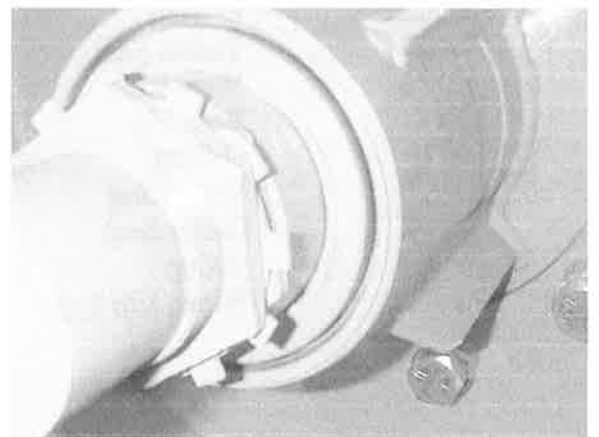

Decal Listing For C & D Model Earthmovers

Part #	Qty	Description	Location
4000931	2	Warning High Pressure	Front Clam Tower (1) Center of Rear Frame (1)
4000933	1	"Do Not Push"	Center of Rear Frame (1)
4000934	2	Loading Loose/Hard Material	Both Sides of Swivel Hitch
4000935	1	Safety/Operation Manual	Front Tongue Near Manual Holder
4000936	2	Tire Pressure/Torque Specs	Both sides of Rear Frame, Near Axle
4000937	2	3 pumps of grease weekly	" "
4000938	26	Grease Daily	Near Each Zerk
4001030	1	Horsepower Rating	Front Tongue Behind Hitch
4000940	2	Danger Pinch/Crush	Front Clam Tower (1) Center of Rear Frame (1)
4000941	1	Danger To Prevent A Hazard	Front Clam Tower
4000944	4	Series 18D	
4000945	4	Series 17C	Both sides of Gate Arm (2)
4000946	4	Series 19C	Both sides of Main Body (2)
4000960	2	ICON 4"	Both sides of Main Body
4000431	3	ICON 3"	Back of Depth Gauge (1) Both sides of Clam Tower (2)
4000948	1	Depth Gauge	Face of Depth Gauge
4000396	1	Gate Gauge	Front of Gate
4000702	4	18" Reflective Tape	Sides & Back of Rear Frame
4000949	1	Hose Color Code	Top of Tongue Behind Hitch
4001248	1	Machine Designed To Be Pulled	Top of Tongue Behind Hitch
4001445	3	Safety Stops	Each Cyl. Stop
4001446	3	Remove Safety Stops	Near ea. Cyl. Stop



Intertek

Equipment from Landoll Corporation is built to exacting standards ensured by ISO 9001 registration at all Landoll manufacturing facilities.

Model 17C/19C Scraper Service and Parts Manual

Re-Order Part Number F-974-0118

LANDOLL CORPORATION

1900 North Street

Marysville, Kansas 66508

(785) 562-5381

800-428-5655 ~ WWW.LANDOLL.COM



Copyright 2014. Landoll Corporation

"All rights reserved, including the right to reproduce this material or portions thereof in any form"