



*Doing Our Best to Provide You the Best*

AS20018, Rev 6  
03/22

---

**ATV SPRAYER**  
**25 Gallon**

---

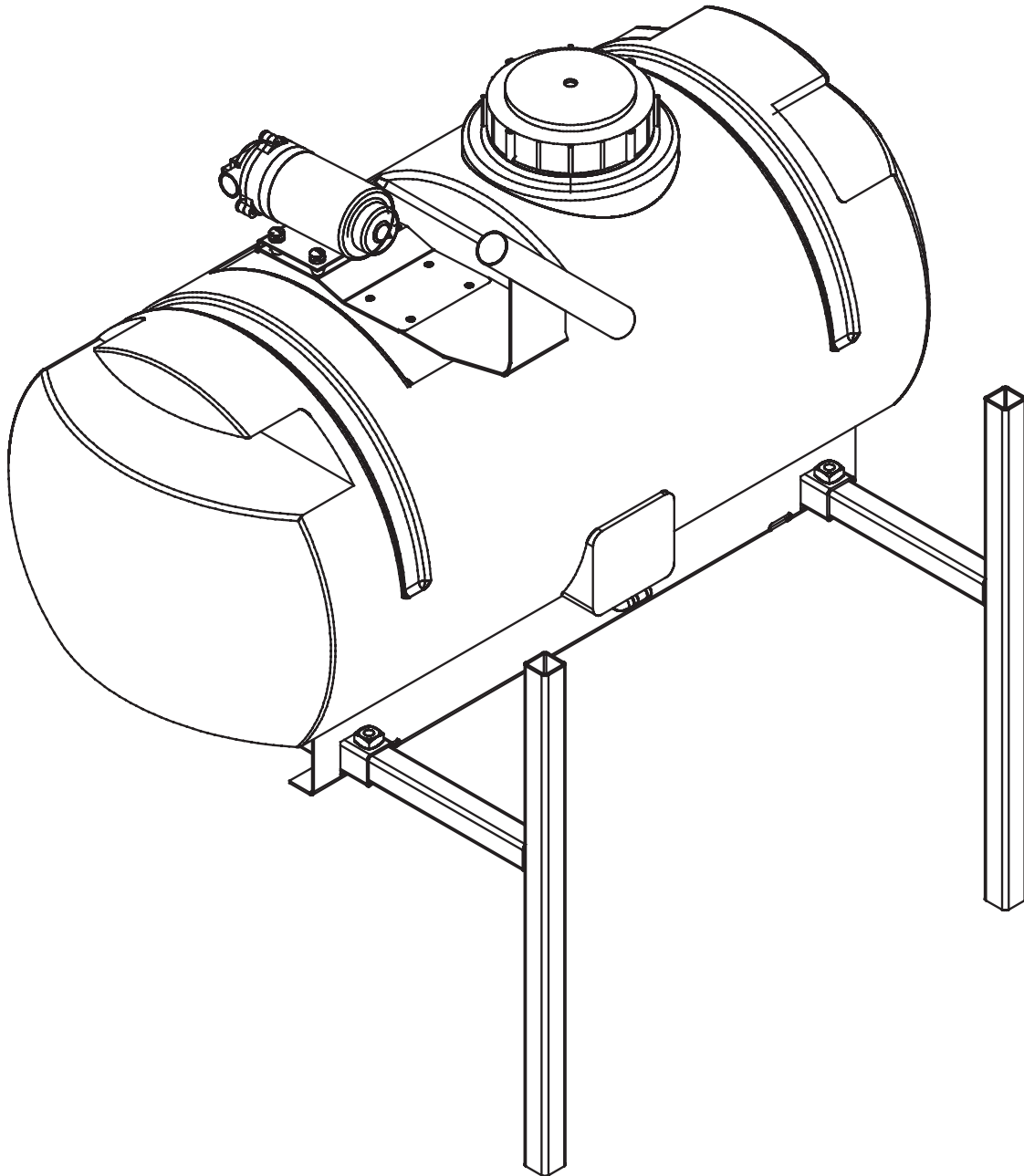

**OPERATOR MANUAL**

## INTRODUCTION

Thank you for purchasing a Demco sprayer. We feel you have made a wise choice and hope you are completely satisfied with your new sprayer. If you have any questions regarding the applications of certain solutions or chemicals, contact your chemical supplier and follow chemical manufacturer recommendations as well as all licensing and use restrictions or regulations.

## WARRANTY POLICY, OPERATOR MANUALS, PARTS MANUALS & REGISTRATION

Go online to [www.demco-products.com](http://www.demco-products.com) to review Demco warranty policies, operator manuals and register your Demco product.



**WARNING: TO AVOID PERSONAL INJURY OR DEATH, OBSERVE FOLLOWING INSTRUCTIONS:**

**Chemicals are dangerous. Know exactly what you're going to do and what is going to happen before attempting to work with these products. Improper selection or use can injure people, animals, plants and soil.**

**Always wear protective clothing such as coveralls, goggles and gloves when working with chemicals or sprayer.**

**Be sure to dispose of all unused chemicals or solutions in a proper and ecologically sound manner.**

## GENERAL INFORMATION

1. Unless otherwise specified, high-strength (grade5) (3 radial-line head markings) hex head bolts are used throughout assembly of this sprayer.
2. Whenever terms "**LEFT**" and "**RIGHT**" are used in this manual it means from a position behind sprayer and facing forward.
3. When placing a parts order, refer to this manual for proper part numbers and place order by **PART NO., DESCRIPTION, and COLOR.**

## TABLE OF CONTENTS

Introduction and Warranty Policy & Registration .....	2
General Information .....	2
Safety You Can Live With .....	4-10
Safety Signs .....	5
Safety Sign Locations .....	5
Bolt Torque .....	11
25 Gallon Parts Breakdown and Assembly Instructions.....	12-13
Main Plumbing Parts Breakdown and List.....	14
Add-on 25 Gallon Tank Parts Breakdown and List.....	15
Boom Mounting Instructions .....	16
Calibration Instructions.....	17-19
Pressure Relief Parts Breakdown and List.....	20
Hand Wand Parts Breakdown .....	20
5 GPM Pump Parts Breakdown and List .....	21
Sprayer Checklist.....	22

**TAKE NOTE! THIS SAFETY ALERT SYMBOL FOUND THROUGHOUT THIS MANUAL IS USED TO CALL YOUR ATTENTION TO INSTRUCTIONS INVOLVING YOUR PERSONAL SAFETY AND SAFETY OF OTHERS. FAILURE TO FOLLOW THESE INSTRUCTIONS CAN RESULT IN INJURY OR DEATH!**



**THIS SYMBOL MEANS  
ATTENTION  
BECOME ALERT  
YOUR SAFETY IS INVOLVED!**

**SIGNAL WORDS:**

This manual uses the following signal words--**DANGER**, **WARNING**, and **CAUTION**-- with safety messages. The appropriate signal word has been selected using the following guidelines.

**DANGER:**

Indicates an imminently hazardous situation that, if not avoided, will result in death or serious injury. This signal word is to be limited to most extreme situations typically for machine components which, for functional purposes, cannot be guarded.

**WARNING:**

Indicates a potentially hazardous situation that, if not avoided, could result in death or serious injury, and includes hazards that are exposed when guards are removed. It may also be used to alert against unsafe practices.

**CAUTION:**

Indicates a potentially hazardous situation that, if not avoided, may result in minor or moderate injury. It may also be used to alert against unsafe practices.

If you have questions not answered in this manual, require additional copies, or if your manual is damaged, please contact your dealer or DEMCO, 4010 320th Street, Boyden, IA 51234  
ph: (712) 725-2311 or Toll Free: 1-800-543-3626 Fax: (712) 725-2380 or 1-800-845-6420  
<http://www.demco-products.com>



## SAFETY...YOU CAN LIVE WITH IT



### EQUIPMENT SAFETY GUIDELINES

Every year many accidents occur which could be avoided by a few seconds of thought and more careful approach to handling equipment. You, the operator, can avoid accidents by observing precautions in this section. To avoid personal injury, study precautions and insist those working with you, or you yourself, follow them.

In order to provide a better view, certain illustrations in this manual may show an assembly with a safety shield removed. However, sprayer should never be operated in this condition. Keep all shields in place. If shield removal becomes necessary for repairs, replace shield prior to use.

Replace any caution, warning, danger or instruction safety decal that is not readable or is missing. Location of such decals is indicated in this booklet.

Do not attempt to operate this sprayer under the influence of alcohol or drugs.

Review safety instructions with all users.

Operator should be a responsible adult. **DO NOT ALLOW PERSONS TO OPERATE OR ASSEMBLE THIS SPRAYER UNTIL THEY HAVE DEVELOPED A THOROUGH UNDERSTANDING OF SAFETY PRECAUTIONS AND HOW IT WORKS.**

To prevent injury or death, use a tractor equipped with a roll over protective system (ROPS). Do not paint over, remove, or deface any safety signs or warning decals on your sprayer. Observe all safety signs and practice instructions on them.

Never exceed limits of sprayer. If its ability to do a job, or to do so safely is in question **DON'T TRY IT.**



### LIGHTING AND MARKING

It is the responsibility of operator to know lighting and marking requirements of local highway authorities and to install and maintain equipment to provide compliance with regulations. Add extra lights when transporting at night or during periods of limited visibility.

Lighting kits are available from your dealer or manufacturer.



**SAFETY SIGN LOCATIONS**

Types of safety sign and locations on equipment are shown in illustration below. Good safety requires that you familiarize yourself with various safety signs, type of warning, and area or particular function related to that area, that requires your SAFETY AWARENESS.

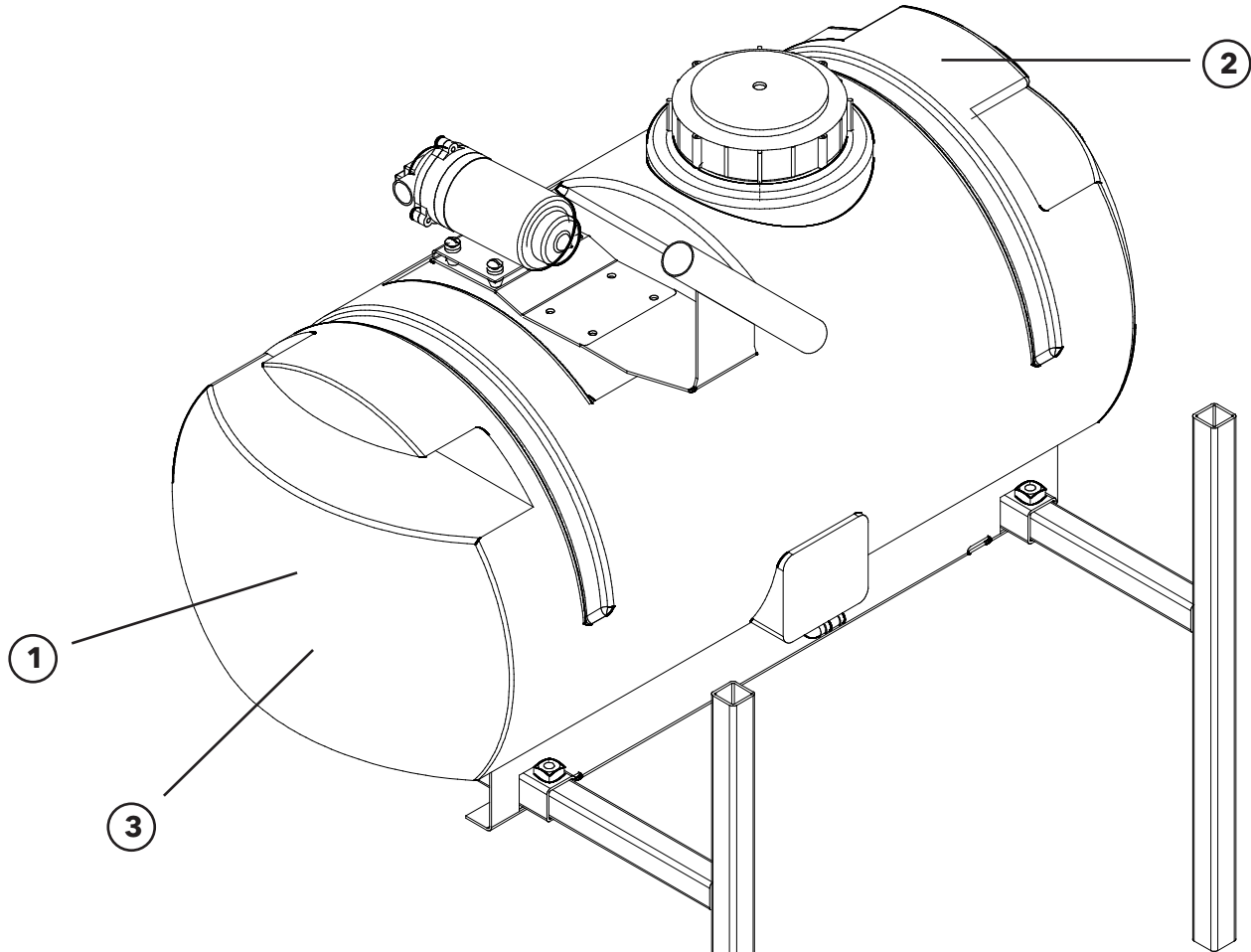

AA21012

REF. NO.	PART NO.	QTY.	DESCRIPTION
1.	AA21012	2	"Demco" Decal
2.	AB21014	1	Warning Decal
3.	AA21002	2	"Boyden, Iowa" Decal

Please order replacement parts by **PART NO.** and **DESCRIPTION.**

①

**⚠ WARNING**

**To prevent serious injury or death**

- Refer to chemical supplier and manufacturer recommendations and all licensing restrictions or regulations.
- Always wear recommended protective clothing when working with chemicals or sprayer.
- Dispose of all unused chemicals or solutions in proper and ecologically sound manner. Improper use can injure people, animals, plants and soil.

REV 1 AB21014

③



AA21002



### SAFETY SIGN CARE

- Keep safety signs clean and legible at all times.
- Replace safety signs that are missing or have become illegible.
- Replacement parts that displayed a safety sign should also display current sign.
- Safety signs are available from your distributor, dealer parts department, or manufacturer.

#### How to install safety signs:

- Be sure installation area is clean and dry.
- Decide on exact position before you remove backing paper.
- Remove smallest portion of split backing paper.
- Align decal over specified area and carefully press small portion with exposed sticky backing in place.
- Slowly peel back remaining paper and carefully smooth remaining portion of decal into place.
- Small air pockets can be pierced with a pin and smoothed out using piece of decal backing paper.



### TIRE SAFETY

- Failure to follow proper procedures when mounting tire on rim can produce an explosion resulting in serious injury or death.
- Do not attempt to mount tire unless you have proper equipment and experience.
- Inflating or servicing tires can be dangerous. Whenever possible, trained personnel should be called to service or mount tires.
- Always order and install tires and wheels with appropriate type and load capacity to meet or exceed anticipated weight to be placed on sprayer.



### REMEMBER

Your best assurance against accidents is a careful and responsible operator. If there is any portion of this manual or function you do not understand, contact your local authorized dealer or manufacturer.



### BEFORE OPERATION:

- Carefully study and understand this manual.
- Do not wear loose-fitting clothing which may catch in moving parts.
- Always wear protective clothing and substantial shoes.
- It is recommended that suitable hearing and eye protection be worn.
- Operator may come in contact with certain materials which may require specific safety equipment relative to handling of such materials. (Examples: extremely dusty, molds, fungus, bulk fertilizers, etc.)

- Keep wheel and lug nuts tightened to specified torque.
- Assure that agricultural implement tires are inflated evenly.
- Give sprayer a visual inspection for any loose bolts, worn parts, or cracked welds, and make necessary repairs. Follow maintenance safety instructions included in this manual.
- Be sure there are no tools lying on or in equipment.
- Do not use the sprayer until you are sure that area is clear, especially around children and animals.
- Don't hurry learning process or take sprayer for granted. Ease into it and become familiar with your new equipment.
- Practice operation of your sprayer and its attachments. Completely familiarize yourself and other operators with its operation before using.
- Use a tractor equipped with Roll Over Protection System (ROPS) and fasten your seat belt prior to starting engine.
- Manufacturer does not recommend usage of tractor with ROPS removed.
- Move tractor wheels to widest recommended settings to increase stability.
- Do not allow anyone to stand between tongue or hitch and towing unit when backing up to equipment.



### DURING OPERATION

- Beware of bystanders, **PARTICULARLY CHILDREN!** Always look around to make sure that it is safe to start engine of towing vehicle or move sprayer. This is particularly important with higher noise levels and quiet cabs, as you may not hear people shouting.
- **NO PASSENGERS ALLOWED** - Do not carry passengers anywhere on or in tractor or sprayer.
- Keep hands and clothing clear of moving parts.
- Do not clean, lubricate, or adjust your sprayer while it is moving.
- When halting operation, even periodically, set tractor or towing vehicles brakes, disengage PTO, shut off engine, and **remove ignition key**.
- Be especially observant of operating area and terrain. Watch for holes, rocks, or other hidden hazards. Always inspect area prior to operation.
  - DO NOT operate near edge of drop-off or banks.
  - DO NOT operate on steep slopes as overturn may result.
  - Operate up and down (not across) intermediate slopes. Avoid sudden starts and stops.
- Pick the most level possible route when transporting across fields. Avoid edges of ditches, gullies, and steep hillsides.
- Be extra careful when working on inclines.

- Maneuver tractor or towing vehicle at safe speeds.
- Avoid overhead wires or other obstacles. Contact with overhead lines could cause serious injury or death.
- Avoid loose gravel, rocks, and holes; they can be dangerous for equipment operation or movement.
- Allow for unit length when making turns.
- Do not walk or work under raised components or attachments unless securely positioned and blocked.
- Keep all bystanders, pets, and livestock clear of work area.
- Operate towing vehicle from operators seat only.
- Never stand alongside of unit with engine running or attempt to start engine and/or operate machine while standing alongside of unit.
- Never leave running equipment unattended.
- As a precaution, always recheck hardware on equipment following every 100 hours of operation. Correct all problems. Follow maintenance safety procedures.



### FOLLOWING OPERATION

- Following operation, or when unhitching, stop tractor or towing unit, set brakes, disengage PTO and all power drives, shut off engine and **remove ignition key**.
- Store sprayer in an area away from human activity.
- Do not park sprayer where it will be exposed to livestock for long periods of time. Damage and livestock injury could result.
- Do not permit children to play on or around the stored sprayer.
- Make sure all parked machines are on a hard, level surface and engage all safety devices.
- Wheel chocks may be needed to prevent unit from rolling.



### HIGHWAY AND TRANSPORT OPERATIONS

- **SAFETY CHAINS:** If equipment is going to be transported on a public highway, always follow state and local regulations regarding safety chains and auxiliary lighting. Be sure to check with local law enforcement agencies for your own particular regulations. If required safety chains should be obtained and installed. Only safety chains (not elastic or nylon/plastic tow straps) should be used to retain connection between towing and towed machines in event of separation of primary attaching system. Use a high strength, appropriately sized hitch pin with a mechanical retainer and attach safety chains. Criss cross chains under tongue and secure to draw bar cage, mounting loops, or bumper frame.



- Adopt safe driving practices:
  - Keep brake pedals latched together at all times. **NEVER USE INDEPENDENT BRAKING WITH SPRAYER IN TOW. LOSS OF CONTROL OR UPSET MAY RESULT.**
  - Always drive at a safe speed relative to local conditions and ensure that your speed is low enough for an emergency stop. Keep speed to a minimum.
  - Reduce speed prior to turns to avoid risk of overturning.
  - Always keep tractor or towing unit in gear to provide engine braking when going downhill. Do not coast.
  - Do not drink and drive!
- Comply with state and local laws governing highway safety and movement of farm machinery on public roads.
- Use approved accessory lighting flags and necessary warning devices to protect operators of other vehicles on highway during transport. Various safety lights and devices are available from your dealer.
- Use of flashing amber lights is acceptable in most localities. However, some localities prohibit their use. Local laws should be checked for all highway lighting and marking requirements.
- When driving tractor and sprayer under 20 mph (40 kph) day or night, use flashing amber warning lights and a slow moving vehicle (SMV) identification emblem.
- Plan your route to avoid heavy traffic.
- Be a safe and courteous driver. Always yield to oncoming traffic in all situations, including narrow bridges, intersections, etc.
- Be observant of bridge load ratings. Do not cross bridges rated lower than gross weight of unit you are operating.
- Watch for obstructions overhead and side to side while transporting.
- Always operate equipment in a position to provide maximum visibility at all times. Make allowances for increased length and weight of sprayer when making turns, or stopping.



## PERFORMING MAINTENANCE

- Good maintenance is your responsibility. Poor maintenance is an invitation to trouble.
- Make sure there is plenty of ventilation. Never operate engine of towing vehicle in a closed building. Exhaust fumes may cause asphyxiation.
- Before working on this machine, stop towing vehicle, set brakes, disengage PTO and all power drives, shut off engine and **remove ignition key**.
- Be certain all moving parts and attachments have come to a complete stop before attempting to perform maintenance.
- Always use a safety support and block wheels. Never use a jack to support machine.

- Always use proper tools or equipment for job at hand.
- Use extreme caution when making adjustments.
- Follow torque chart in this manual when tightening bolts and nuts.
- Never use your hands to locate a hydraulic leak on attachments. Use a small piece of cardboard or wood. Hydraulic fluid escaping under pressure can penetrate skin.
- Openings in skin and minor cuts are susceptible to infection from hydraulic fluid.  
**Without immediate medical treatment, serious infection and reactions can occur.**
- When disconnecting hydraulic lines, shut off hydraulic supply and relieve all hydraulic pressure.
- Replace **all shields** and **guards** after servicing and before moving.
- After servicing, be sure all tools, parts and service equipment are removed.
- Do not allow grease or oil to build up on any steps or platform.
- When replacing bolts refer to owners manual.
- Refer to bolt torque chart for head identification marking.
- Where replacement parts are necessary for periodic maintenance and servicing, genuine factory replacement parts must be used to restore your equipment to original specifications. Manufacturer will not claim responsibility for use of unapproved parts or accessories and other damages as a result of their use.
- If equipment has been altered in any way from original design, manufacturer does not accept any liability for injury or warranty.
- A fire extinguisher and first aid kit should be kept readily accessible while performing maintenance on this equipment.



**TORQUE SPECIFICATION**

Torque figures indicated are valid for non-greased or non-oiled threads and heads unless otherwise specified. Therefore, do not grease or oil bolts or capscrews unless otherwise specified in this manual. When using locking elements, increase torque values by 5%.

\* GRADE or CLASS value for bolts and capscrews are identified by their head markings.

**BOLT TORQUE DATA FOR STANDARD NUTS, BOLTS, AND CAPSCREWS.**

Tighten all bolts to torques specified in chart unless otherwise noted. Check tightness of bolts periodically, using bolt chart as guide. Replace hardware with same grade bolt.

NOTE: Unless otherwise specified, high-strength Grade 5 hex bolts are used throughout assembly of equipment.

Bolt Torque for Standard bolts *						
"A"	GRADE 2		GRADE 5		GRADE 8	
	lb-ft	(N.m)	lb-ft	(N.m)	lb-ft	(N.m)
1/4"	6	(8)	9	(12)	12	(16)
5/16"	10	(13)	18	(25)	25	(35)
3/8"	20	(27)	30	(40)	45	(60)
7/16"	30	(40)	50	(70)	80	(110)
1/2"	45	(60)	75	(100)	115	(155)
9/16"	70	(95)	115	(155)	165	(220)
5/8"	95	(130)	150	(200)	225	(300)
3/4"	165	(225)	290	(390)	400	(540)
7/8"	170	(230)	420	(570)	650	(880)
1"	225	(300)	630	(850)	970	(1310)

Bolt Torque for Metric bolts *						
"A"	CLASS 8.8		CLASS 9.8		CLASS 10.9	
	lb-ft	(N.m)	lb-ft	(N.m)	lb-ft	(N.m)
6	9	(13)	10	(14)	13	(17)
7	15	(21)	18	(24)	21	(29)
8	23	(31)	25	(34)	31	(42)
10	45	(61)	50	(68)	61	(83)
12	78	(106)	88	(118)	106	(144)
14	125	(169)	140	(189)	170	(230)
16	194	(263)	216	(293)	263	(357)
18	268	(363)	--	--	364	(493)
20	378	(513)	--	--	515	(689)
22	516	(699)	--	--	702	(952)
24	654	(886)	--	--	890	(1206)

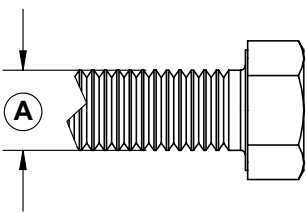

**GRADE-2**

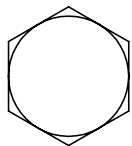

**GRADE-5**

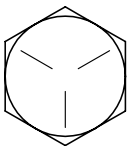

**GRADE-8**

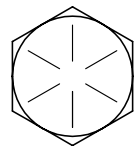

**CLASS 8.8**

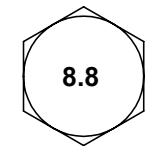

**CLASS 9.8**

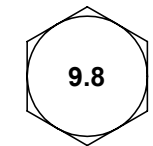

**CLASS 10.9**



# PARTS BREAKDOWN

## 25 GALLON

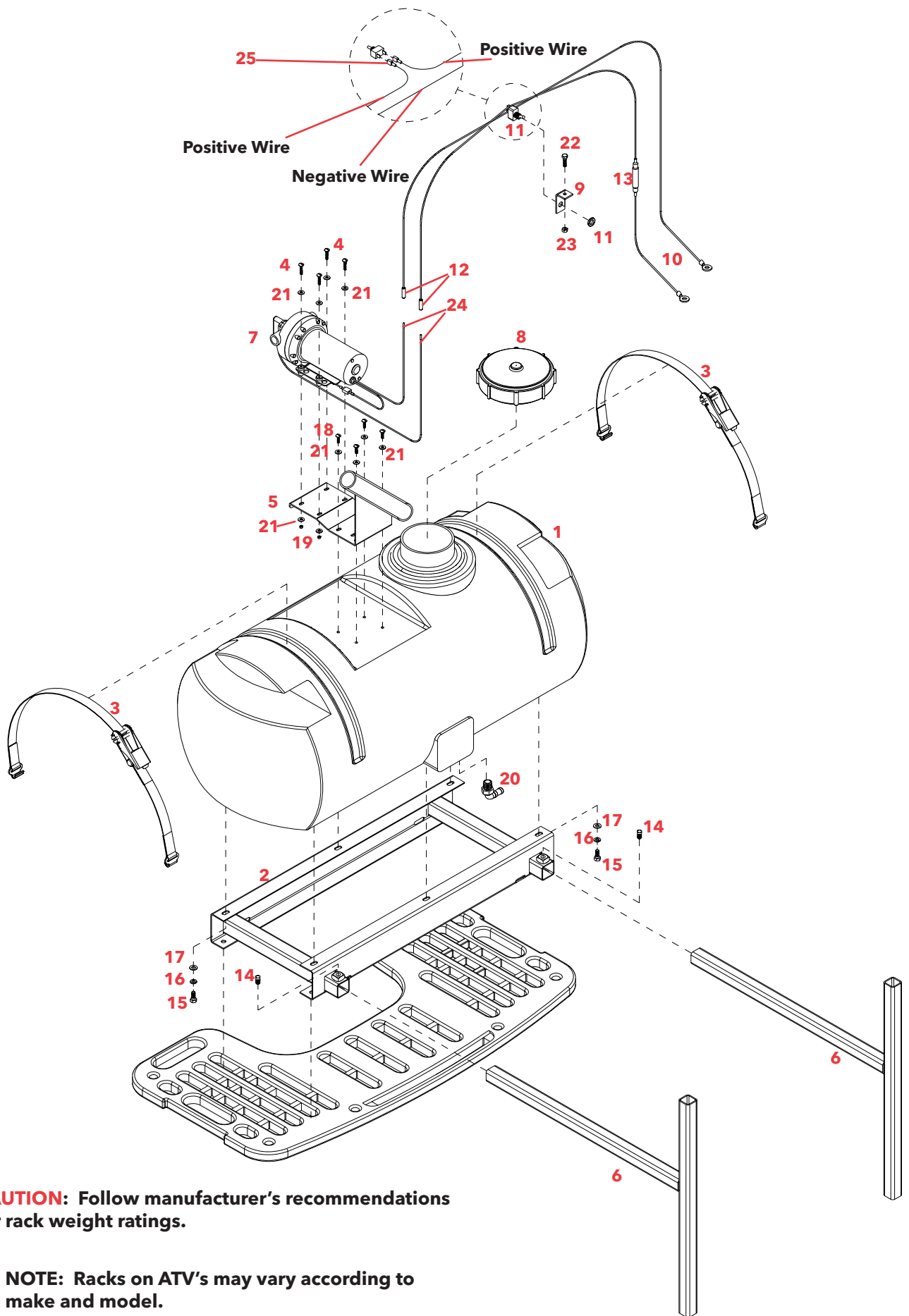

**CAUTION:** Follow manufacturer's recommendations for rack weight ratings.

**NOTE:** Racks on ATV's may vary according to make and model.

## 25 GALLON PARTS BREAKDOWN AND ASSEMBLY INSTRUCTIONS

1. Start by threading a BEL1212 (#20) into the fitting on the bottom of the tank.
2. Thread two 3/8" x 3/4" Set Screws (#14) into the weldnuts on the frame. Make sure you can still get the boom mounts into the tubes. Next fasten the tank (#1) to the skid (#2) using six 5/16" x 3/4" hex head bolts (#15), six 5/16" spring lock washers (#16), and six 5/16" flat washers (#17).
3. Next mount the pump (#7) to the pump mount (#5) using four #10 UNC x 1" slotted Truss head bolts (#4), four #10 Flat Washers (#21), and four #10 UNC Hex Nuts (#19). Mount this assembly to the top of the tank using four #10 UNC x 3/4" slotted round head bolts (#18) and four #10 Flat Washers (#21).
4. Place the tank and skid on the rear rack of the ATV. Make sure that the skid is as far back as possible without causing damage to the fitting in the bottom of the tank. Secure the sprayer to the rack using the two straps and ratchets (#3). Loop the hook end of the straps around a bar of the rack and secure them on the frame. Then run the strap around the top of the tank. Use the ratchet to tighten as needed.
5. Insert the two boom mounts (#6) and secure into place with the two 3/8" x 3/4" Set Screws (#14).
6. Mount Switch Bracket (#9) in a convenient location using the 1/4" x 1" Bolt (#22) and 1/4" Nylon Insert Locknut (#23) provided.

REF. NO.	PART NO.	REQ'D QTY.	DESCRIPTION
1.	<b>P25 18A</b>	1	25 gal. Tank (1/2" spinweld & Lid incld)
2.	<b>10948-30</b>	1	25 gal. Skid
3.	<b>10984</b>	2	Nylon Strap (Rachets incld)
4.	<b>05483</b>	4	#10 UNC x 1 1/4" Slotted Truss Head Bolt
5.	<b>11012-30</b>	1	Pump Mount / Hand Gun Holder
6.	<b>10950-30</b>	2	Boom Mounts
7.	<b>12981</b>	1	Electric Pump
8.	<b>PL5A</b>	1	Replacement Lid (included w/ P25 18 Tank)
9.	<b>04755-95</b>	1	Switch Mount Bracket
10.	<b>04764</b>	1	10' Wire Harness
11.	<b>01013</b>	1	Replacement Switch w/nut (incld w/ 04764)
12.	<b>05021</b>	2	Female Bullet Connector (included w/ 04764)
13.	<b>09272</b>	1	Replacement Fuse (included w/ 04764) 20 AMP
14.	<b>00095</b>	2	3/8" UNC x .75" Square Head Set Screw
15.	<b>01263</b>	6	5/16" UNC x .75" Hex Head Bolt
16.	<b>00036</b>	6	5/16" Spring Lockwasher
17.	<b>00004</b>	6	5/16" Flatwasher
18.	<b>04208</b>	4	#10 UNC x .75" Slotted Rnd Head bolt
19.	<b>02205</b>	4	#10 UNC Nylon Insert Locknut
20.	<b>BEL1212</b>	1	1/2" MPT x 1/2" HB Fitting
21.	<b>07490</b>	12	#10 UNC Flat Washer
22.	<b>04055</b>	1	1/4" UNC x 1" Hex Head Bolt
23.	<b>02772</b>	1	1/4" UNC Nylon Insert Locknut
24.	<b>05020</b>	2	Male Bullet Wire Connector
25.	<b>05004</b>	2	Female Push-On Terminal End Wire Connector

Please order replacement parts by **PART NO.** and **DESCRIPTION.**

# PLUMBING BREAKDOWN

## MAIN PLUMBING PARTS BREAKDOWN

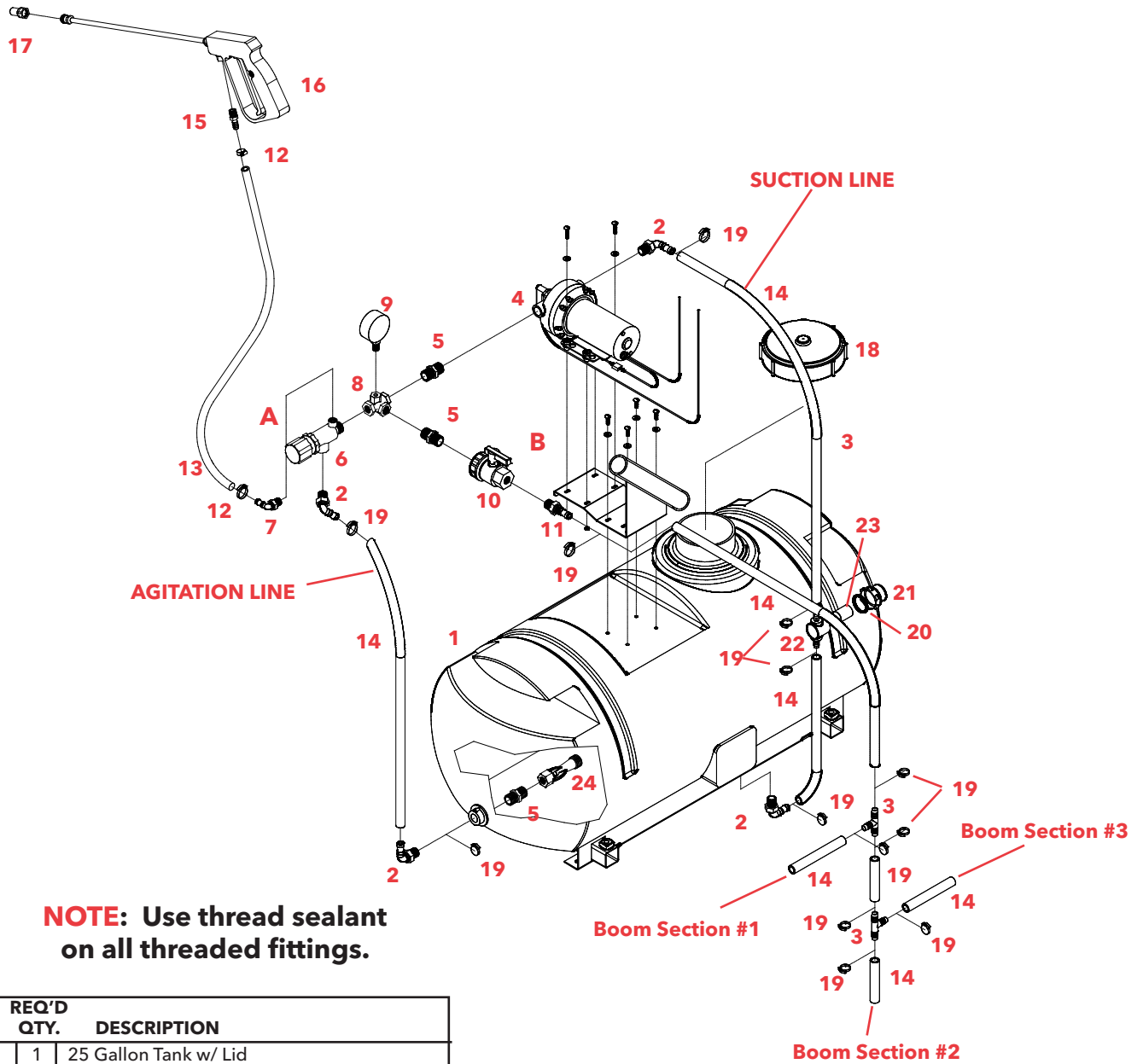

**NOTE:** Use thread sealant on all threaded fittings.

REF. NO.	PART NO.	REQ'D QTY.	DESCRIPTION
1	<b>P25 18A</b>	1	25 Gallon Tank w/ Lid
2	<b>BEL1212</b>	4	1/2" MPT X 1/2" HB Fitting
3	<b>T12</b>	2	1/2" HB Tee
4	<b>12981</b>	1	Electric Pump (5GPM)
5	<b>M1200</b>	3	1/2" MPT Nipple
6	<b>23120PP</b>	1	Pressure Relief Valve
7	<b>EL1438</b>	1	1/4" MPT x 3/8" HB Elbow
8	<b>BTT12G</b>	1	1/2" FPT w/ 1/4" Gauge Port
9	<b>100GB</b>	1	100# Brass Gauge (Not Shown)
10	<b>UV050FP</b>	1	1/2" Ball Valve
11	<b>BA1212</b>	1	1/2" MPT X 1/2" HB Straight Fitting
12	<b>B6PH</b>	2	3/8" Hose Clamp
13	<b>38ORB</b>	-	3/8" Rubber Hose
14	<b>120RB</b>	-	1/2" Rubber Hose
15	<b>A1438</b>	1	1/4" MPT X 3/8" HB Straight Fitting
16	<b>12434</b>	1	18" Hand Gun (includes tip)
17	<b>12496</b>	1	Adjustable Spray Tip
18	<b>PL5A</b>	1	Replacement Lid
19	<b>B8PH</b>	16	Nylon Hose Clamp for 1/2" Hose
-	<b>RVB12 80</b>	1	Strainer Assembly w/ 80 Mesh Screen
20	<b>RVB38GE</b>	1	EPDM Gasket for Strainer
21	<b>RVB38B</b>	1	Strainer Bowl
22	<b>RVF38C</b>	1	Strainer Cap
23	<b>RVB80</b>	1	80 Mesh Strainer Screen
24	<b>5044 1</b>	1	Single Agitation Wand Assembly

## OPERATING INSTRUCTIONS

1. Fill the tank with water.
2. Open (counter clockwise) the pressure relief valve **(A)**.
3. Open the Ball valve **(B)** so that all the boom sections are spraying.
4. Start and run pump.
5. Slowly close the pressure relief valve **(A)** until the desired spraying pressure is reached with the boom spraying.
6. Check for leaks.

Please order replacement parts by **PART NO.** and **DESCRIPTION.**

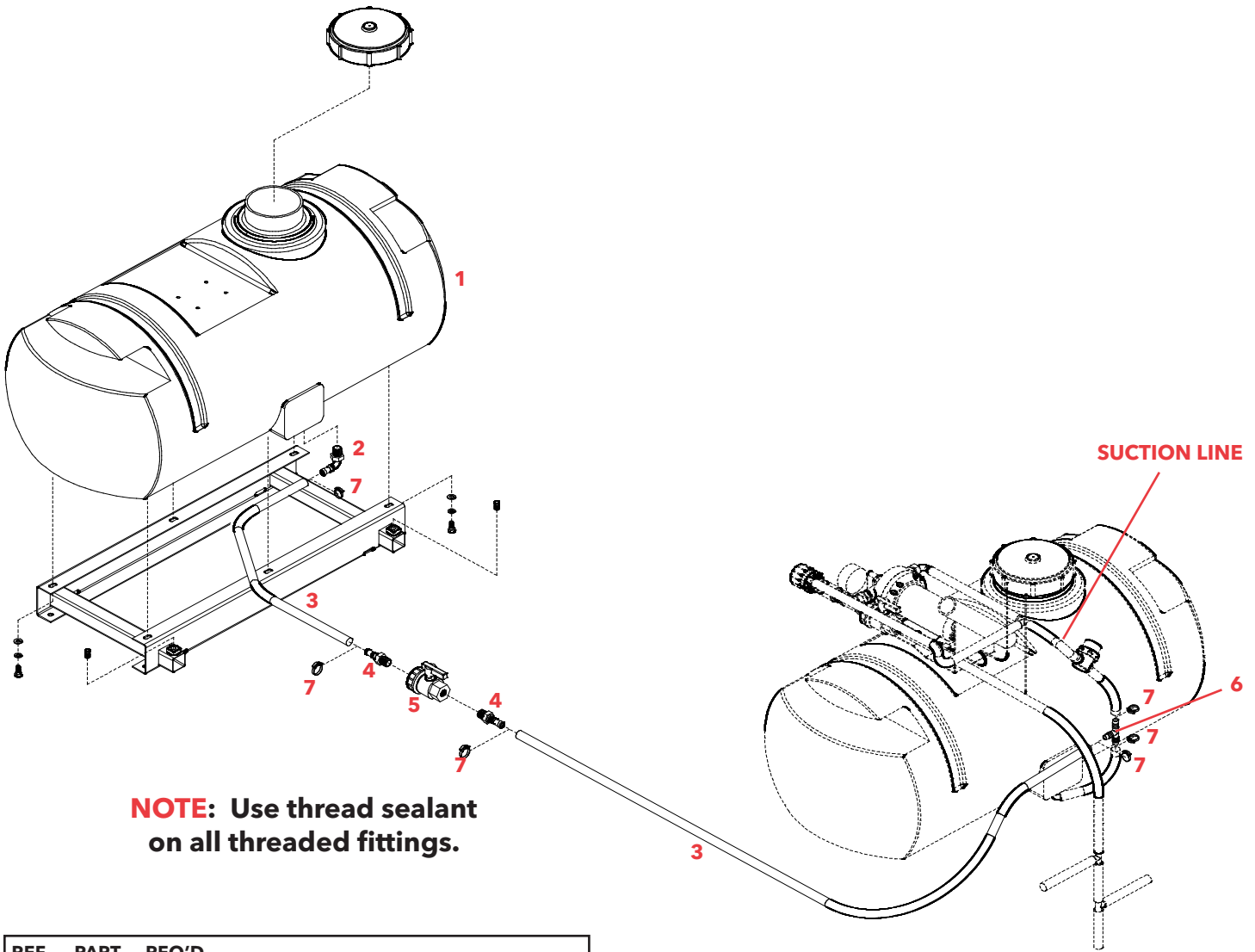

**NOTE:** Use thread sealant on all threaded fittings.

REF. NO.	PART NO.	REQ'D QTY.	DESCRIPTION
1.	P25 18A	1	25 Gallon Tank w/Lid
2.	BEL1212	1	1/2" MPT X 1/2" HB Elbow
3.	120RB	-	1/2" Rubber Hose
4.	BA1212	2	1/2" MPT X 1/2" HB Straight Fitting
5.	UV050FP	1	1/2" Ball Valve
6.	T12	1	1/2" HB Tee
7.	B8PH	6	1/2" Nylon Hose Clamp

Please order replacement parts by **PART NO.** and **DESCRIPTION.**

1. Begin by strapping the tank to the front of the ATV just like you did the back tank (See page 13 for mounting instructions). Next assemble the ball valve and fittings as shown.
2. Attach one end of the hose to the elbow fitting on the bottom of the front tank with a B8PH. Next cut the hose where the ball valve will be accessible when sitting on the ATV. Attach the ball valve assembly to the end of the hose from the front tank as shown with a B8PH clamp. Attach the excess hose to the other end of the ball valve assembly using a B8PH as shown.
3. Next make a cut in the suction line on the back tank as shown. Insert a T12 and secure using two B8PH's. Run the hose coming from the front tank so that it will not get caught on anything or hinder the operation of the ATV. Attach this hose to the T12 you put into the suction line using a B8PH and cut off any excess if needed.

# MOUNTING INSTRUCTIONS

## BOOM MOUNTING INSTRUCTIONS

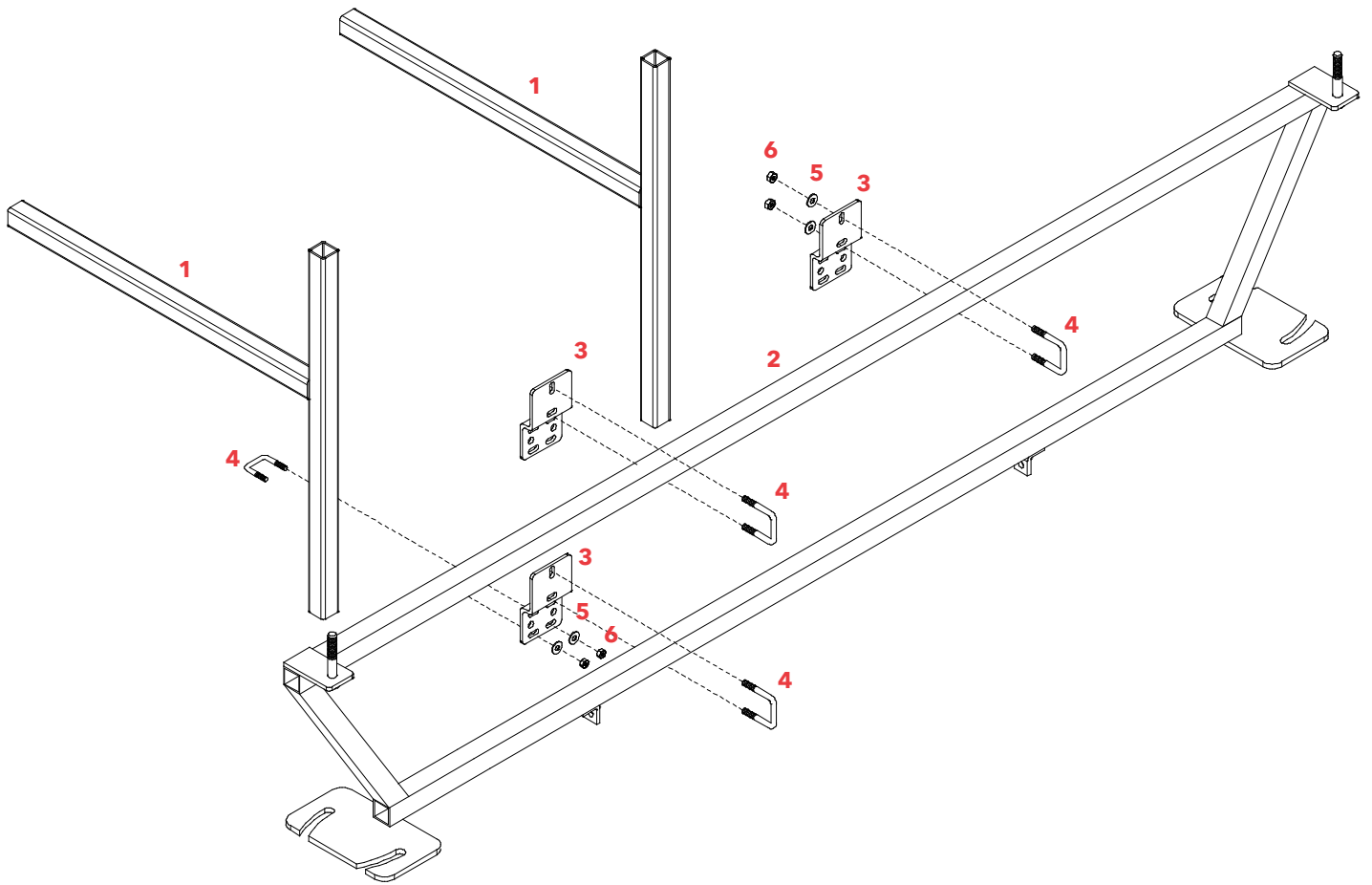

1. Attach the mounting plates (#3) to the center section (#2) using four 5/16" X 1-1/4" square u-bolts (#4), eight 5/16" flatwashers (#5), and eight 5/16" nylon insert locknuts (#6). Leave these loose at this time to allow for adjustment.

2. Now attach this assembly to the boom mounts (#1) on the ATV using four 5/16" X 1-1/4" square u-bolts (#4), eight 5/16" flatwashers (#5), and eight 5/16" nylon insert locknuts (#6). Adjust the center section to the desired spray height and tighten all nuts at this time.

REF. NO.	PART NO.	QTY.	DESCRIPTION
1.	10950-30	2	Boom Mounts
*2.	02680-10	1	Truss-T Center Section
*3.	02678-95	4	Boom Mounting Plate
*4.	00909	8	5/16"-18 UNC 1-1/4" Square U-Bolt
*5.	00004	16	5/16" Flatwasher
*6.	02802	16	5/16" Nylon Insert Locknut

Please order replacement parts by **PART NO.** and **DESCRIPTION.**

**\* Parts included with the boom**

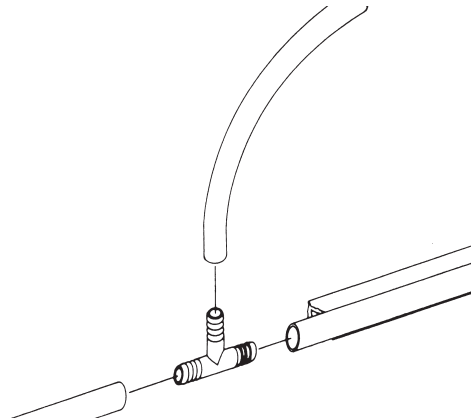

**\*NOTE:** Truss-T booms come standard with 1/2" hose and T's.



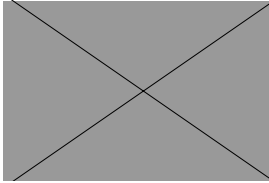

**Spray Tip Chart for 80" and 144" Booms**

Tip No.	Liquid Pressure in PSI	Capacity 1 Nozzle in GPM	GALLONS PER ACRE 40" TIP SPACING							
			2 MPH	3 MPH	4 MPH	5 MPH	6 MPH	7 MPH	8 MPH	
AN1.5	10	.15	11.2	7.5	5.6	4.5	3.7	3.2	2.8	
	20	.21	15.8	10.5	7.9	6.3	5.3	4.6	3.9	
	30	.26	19.4	12.9	9.7	7.7	6.4	5.6	4.8	
	40	.30	22.2	14.8	11.1	8.9	7.4	6.5	5.6	

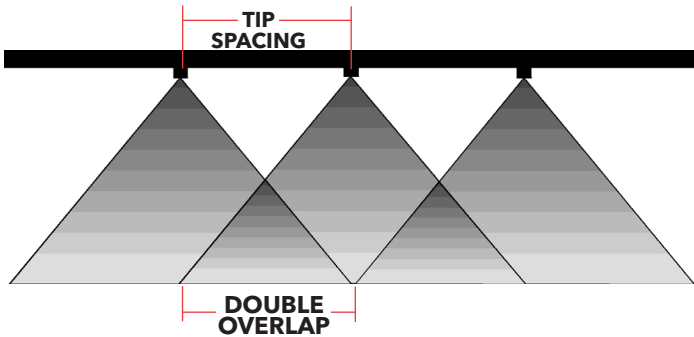

There is not a standard spray height for FloodJet tips. Raise or lower the spray boom... or rotate nozzle tips to double overlap spray patterns and provide optimum coverage along spray boom.

When switching from one chemical to another chemical in the sprayer where contamination must be prevented, wash out with ammonia and water through the tank, pump and all hose. Then flush with water two or three times. Herbicides such as 2-4-D are hard to remove. After using them, follow the special cleaning procedures noted on the pesticide label.

Use the following formula to determine your ratio per acre.

- GPA** - Gallons Per Acre
- GPM** - Gallons Per Minute
- MPH** - Miles Per Hour

$$GPA = \frac{5940 \times GPM \text{ (Per Nozzle)}}{MPH \times W^*}$$

\* W - Nozzle spacing in inches.

**RATES OF FLOW...for calibrating spray tips.**

GPM	seconds to collect 1 qt.	GPM	seconds to collect 1 qt.
.05	300	.20	75
.06	250	.225	67
.07	214	.25	60
.08	188	.30	50
.09	167	.35	43
.10	150	.40	38
.11	136	.50	30
.12	125	.60	25
.13	115	.70	21
.14	107	.80	19
.15	100	.90	17
.17	88	1.0	15

**Important:** Replace all worn tips and those with streaky or uneven patterns.

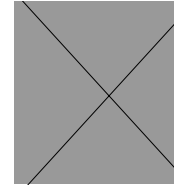

**Spray Tip Chart for 90" Booms**

Tip No.	Liquid Pressure in PSI	Capacity 1 Nozzle in GPM	GALLONS PER ACRE 30" TIP SPACING							
			2 MPH	3 MPH	4 MPH	5 MPH	6 MPH	7 MPH	8 MPH	
LP015 110	15	.15	14.8	9.9	7.4	5.9	5.0	4.2	3.7	
	20	.17	17.2	11.5	8.6	6.9	5.7	4.9	4.3	
	30	.21	21.0	14.0	10.5	8.4	7.0	6.0	5.3	
	40	.24	24.2	16.2	12.1	9.7	8.1	6.9	6.0	

**Spray Tip Chart for Single Tip (40") Booms**

Tip No.	Liquid Pressure in PSI	Capacity 1 Nozzle in GPM	GALLONS PER ACRE 40" TIP SPACING							
			2 MPH	3 MPH	4 MPH	5 MPH	6 MPH	7 MPH	8 MPH	
LP015 110	15	.15	11.2	7.5	5.6	4.5	3.7	3.2	2.8	
	20	.17	13.0	8.7	6.5	5.2	4.3	3.7	3.2	
	30	.21	15.8	10.5	7.9	6.3	5.3	4.5	3.7	
	40	.24	18.2	12.1	9.1	7.3	6.1	5.2	4.6	

Acre = 43,560 square feet

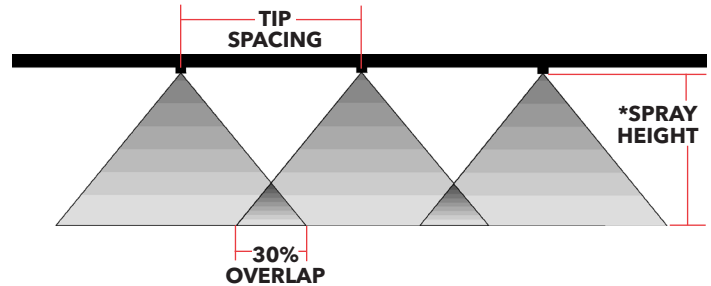

\*approximately 13-1/2" for 30" coverage.

\*approximately 15" for 40" coverage.

This tip (LP015 110) is specially designed to operate at low pressure, and wide angle allowing the boom to be run close to the ground for less spray drift.

**VEHICLE SPEEDS**

Mark off a distance of 100, 200 or 300 feet. Run the lawn mower or all terrain vehicle over this distance, carefully marking the throttle setting or speedometer reading. To make measurement of test run, begin from a standing start far enough ahead of the first marker so that your rig is at full speed before traveling the 100, 200 or 300 foot distances.

speed in MPH (miles per hr.)	time required in SECONDS to travel:		
	100 feet	200 feet	300 feet
3.0	23	45	68
4.0	17	34	51
5.0	14	27	41
6.0	11	23	34
7.0	9.7	19	29
8.0	8.5	17	26
10	6.8	14	20

# SPRAYER CALIBRATION PROCEDURES

## SPRAYER CALIBRATION PROCEDURES

**NOTE:** To avoid wind drift, use lower pressure and higher spray volume.

### Guidelines For Sprayer Calibration

Before calibrating your sprayer, first determine whether each nozzle is delivering at a uniform rate. Place quart jars under all nozzles and watch as they fill up. The level should rise uniformly and take the same time (within 10%) for all nozzles to fill the jars. Replace any nozzle showing a discharge rate different from the others.

## Calibrating the Sprayer

1. Mark off 660 feet (1/8 mile).
2. Fill the tank with water.
3. Set the sprayer to your desired operating pressure.
4. Turn the sprayer on and drive at the constant speed you will be spraying. Calibration on a road or unplowed field will give different results than on soft cultivated ground. **Note** tachometer reading so same speed can be maintained later.
5. Measure the amount of water it takes to refill the tank completely.
6. Calculate the amount applied:

$$\frac{\text{Number of gallons used} \times 66 \text{ (factor)}}{\text{Spray Swath in Feet}} = \text{Gallons applied per acre}$$

**Example:** If 10 gallons are used in 660 feet and the spray swath is 28 feet, spraying rate is 23.57 gallons per acre.

$$\frac{10 \times 66}{28} = \frac{660}{28} \text{ or } 23.57 \text{ gallons per acre}$$

7. To calculate the amount of chemical to put in the tank:

$$\frac{\text{Sprayer Tank Size}}{\text{Desired GPA}} = \text{Acres covered} \quad \text{then;}$$

$$\text{Recom. amount of chemical per acre} \times \text{Acres covered} = \text{Amt. of chemical per tankful}$$

**Example:** If a 300 gallon tank is used and 23.57 gallons per acre are applied, one tank will cover 12.72 acres. If three pounds of chemical are required per acre, then 38.1 pounds of chemical are required per tankful.

$$\frac{300}{23.57} = 12.72 \text{ acres covered then;}$$

$$3 \text{ lbs. (gal.)} \times 12.72 = 38.1 \text{ lbs. (gal.) per tankful}$$

**To determine GPA at other nominal speeds.**

Sprayer Speed	Multiply by Speed Factor
4 mph	1.25
5 mph	1.00
6 mph	.83
7.5 mph	.67
10 mph	.50

**FLAT SPRAY NOZZLE  
FOR BROADCAST SPRAYING**

Nozzle No.	Liquid Pressure In PSI.	Nozzle Capacity In GPM	Gallons Per Acre Based on 20" Nozzle Spacing			
			4 MPH	5 MPH	7.5 MPH	10 MPH
			8001 or XR8001VS	20 25 30 40	.07 .08 .09 .10	5.3 5.9 6.4 7.4
80015 or XR80015VS	20 25 30 40	.11 .12 .13 .15	7.8 8.8 9.7 11.1	6.3 7.1 7.7 8.9	4.3 4.7 5.2 6.0	3.2 3.6 3.9 4.5
8002 or XR8002VS	20 25 30 40	.14 .16 .17 .20	10.5 11.8 12.9 14.8	8.4 9.4 10.3 11.8	5.6 6.3 6.9 7.9	4.2 4.7 5.2 5.9
8003 or XR8003VS	20 25 30 40	.21 .24 .26 .30	15.7 17.6 19.0 22.0	12.6 14.1 15.4 17.8	8.4 9.4 10.3 11.8	6.3 7.1 7.7 8.9
8004 or XR8004VS	20 25 30 40	.28 .32 .35 .40	21.0 24.0 26.0 30.0	16.8 18.7 21.0 24.0	11.2 12.5 13.7 15.8	8.4 9.4 10.3 11.9
8005 or XR8005VS	20 25 30 40	.35 .40 .43 .50	26.0 29.0 32.0 37.0	21.0 23.0 26.0 30.0	14.0 15.7 17.2 19.8	10.5 11.7 12.9 14.9
8006 or XR8006VS	20 25 30 40	.42 .47 .52 .60	31.0 35.0 39.0 45.0	25.0 28.0 31.0 36.0	16.9 18.7 21.0 24.0	12.6 14.1 15.5 17.8
8008 or XR8008VS	20 25 30 40	.56 .63 .69 .80	42.0 47.0 52.0 59.0	34.0 37.0 41.0 48.0	22.0 25.0 27.0 32.0	17.0 19.0 21.0 24.0
8010 or XR8010VS	20 25 30 40	.70 .78 .86 1.00	53.0 59.0 64.0 74.0	42.0 47.0 51.0 59.0	28.0 31.0 34.0 40.0	21.0 24.0 26.0 30.0

Tabulations for all the following charts are based on spraying water. For different weight fertilizer solutions, obtain the appropriate conversion factor from the table below.

Weight of Solution	Specific Gravity	Conversion Factors
7.0 lbs. per gallon	.84	1.09
8.0 lbs. per gallon	.96	1.02
<b>8.34 lbs. per gallon-WATER</b>	<b>1.00</b>	<b>1.00</b>
9.0 lbs. per gallon	1.08	.96
10.0 lbs. per gallon	1.20	.91
11.0 lbs. per gallon	1.32	.87
12.0 lbs. per gallon	1.44	.83
14.0 lbs. per gallon	1.68	.77
16.0 lbs. per gallon	1.92	.72
18.0 lbs. per gallon	2.16	.68
20.0 lbs. per gallon	2.40	.65

Imperial Gallon = 1.20 U.S.A. Gallons

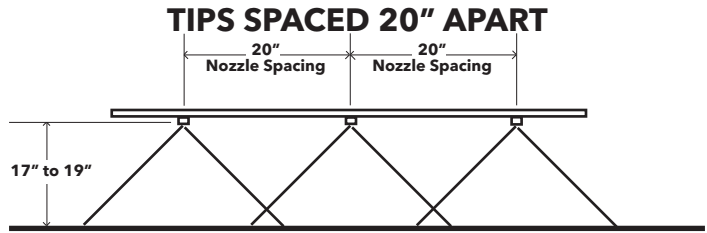

**FLOODJET TIPS  
FOR BROADCAST SPRAYING**

Nozzle No.	Orifice Dia.	Liquid Pressure In PSI.	Capacity In GPM.	Gallons Per Acre				
				4 MPH	5 MPH	6 MPH	8 MPH	10 MPH
TKVS1	.033"	10	.10	3.7	3.0	2.5	1.9	1.5
		20	.14	5.3	4.3	3.5	2.6	2.1
		30	.17	6.4	5.1	4.2	3.2	2.6
		40	.20	7.4	6.0	4.9	3.7	3.0
TKVS1.5	.041"	10	.15	5.6	4.5	3.7	2.7	2.0
		20	.21	7.8	6.3	5.2	3.9	2.9
		30	.26	9.7	7.7	6.5	4.8	3.5
		40	.30	11.1	8.9	7.4	5.6	4.1
TKVS2	.046"	10	.20	7.4	6.0	4.9	3.7	3.0
		20	.28	10.5	8.4	6.9	5.2	4.2
		30	.35	12.9	10.3	8.7	6.5	5.2
		40	.40	14.8	11.8	9.9	7.5	5.9
TKVS2.5	.052"	10	.25	9.3	7.4	6.1	4.6	3.7
		20	.35	12.9	10.3	8.7	6.5	5.2
		30	.43	15.9	12.8	10.6	8.0	6.4
		40	.50	18.6	14.9	12.4	9.3	7.4
TKVS3	.057"	10	.30	11.1	8.9	7.5	5.6	4.5
		20	.42	15.7	12.6	10.4	7.8	6.3
		30	.52	19.3	15.4	12.8	9.7	7.7
		40	.60	22.0	17.8	14.8	11.2	8.9
TKVS4	.065"	10	.40	14.9	11.9	9.9	7.5	5.9
		20	.57	21.0	16.8	13.9	10.5	8.4
		30	.69	26.0	21.0	17.1	12.8	10.3
		40	.80	30.0	24.0	19.8	14.8	11.9
TKVS5	.073"	10	.50	18.6	14.9	12.4	9.3	7.4
		20	.71	27.0	21.0	17.6	13.1	10.7
		30	.87	33.0	26.0	21.7	16.1	13.1
		40	1.00	38.0	30.0	25.2	18.6	15.1
TKVS7.5	.091"	10	.75	28.0	22.0	18.7	14.0	11.1
		20	1.10	39.0	32.0	26.4	19.8	15.8
		30	1.30	49.0	39.0	31.9	24.1	19.3
		40	1.50	56.0	45.0	37.4	27.5	22.0
TKVS10	.104"	10	1.00	38.0	30.0	25.2	18.5	15.1
		20	1.40	53.0	41.7	35.2	26.4	21.0
		30	1.70	64.0	51.0	41.7	31.9	26.0
		40	2.00	75.0	60.0	49.4	37.4	30.0
TKSS15	.129"	10	1.50	56.0	45.0	37.4	27.5	22.0
		20	2.10	79.0	63.0	51.6	39.6	31.0
		30	2.60	97.0	77.0	64.8	48.3	39.0
		40	3.00	111.0	89.0	74.7	56.0	45.0
TKSS20	.148"	10	2.00	75.0	60.0	49.4	37.4	30.0
		20	2.80	104.0	83.0	69.2	52.7	42.0
		30	3.50	130.0	104.0	86.8	64.8	52.0
		40	4.00	149.0	119.0	100.0	74.7	59.0
TKSS30	.180"	10	3.00	111.0	89.0	74.7	56.0	45.0
		20	4.2	156.0	124.0	104.4	78.2	62.0
		30	5.10	189.0	151.0	126.4	95.6	76.0
		40	6.000	222.0	178.0	149.4	112.0	89.0

Floodjet tips are positioned as shown in the diagram by the chart below. When positioning the tip as shown in Figure A the chance of wind drift is reduced.

The chart below shows capacities in gallons per acre at various speeds and liquid pressures. Capacities are based on water at 70 degrees F. with nozzles spaced at 40 inches.

The rate chart is based on 40 inch row spacings. For other spacings of nozzles on the boom, multiply the tabulated GPA coverage by the conversion factors shown below.

Other Spacing	20	24	28	30	32	34	36	38	40	42	44
Conversion Factor	2	1.67	1.43	1.33	1.25	1.18	1.11	1.05	1.00	.95	.91

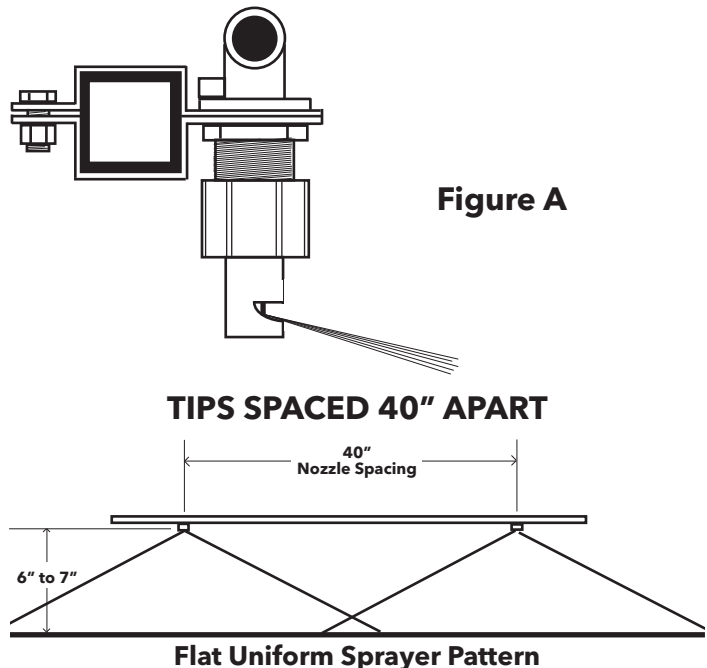

**(23120PP) PRESSURE RELIEF VALVE PARTS BREAKDOWN**

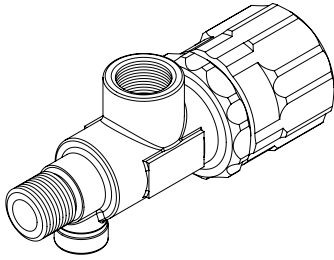

**(23120PP) BYPASS VALVE PARTS LIST**

PART NO.	DESCRIPTION
<b>AB23120</b>	Repair Kit (Includes Guide Pin, Rubber O-Ring, and Spring)

Please order replacement parts by **PART NO.** and **DESCRIPTION.**

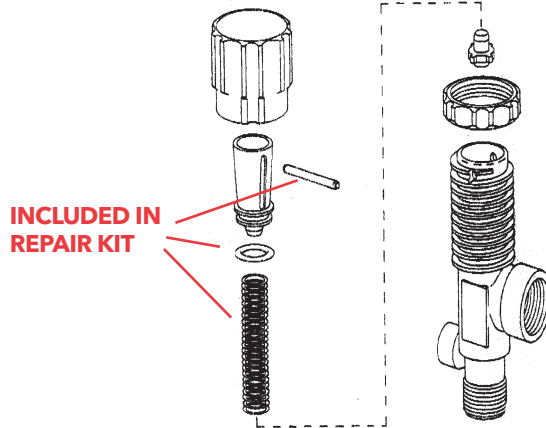

**SPRAY WAND PARTS BREAKDOWN**

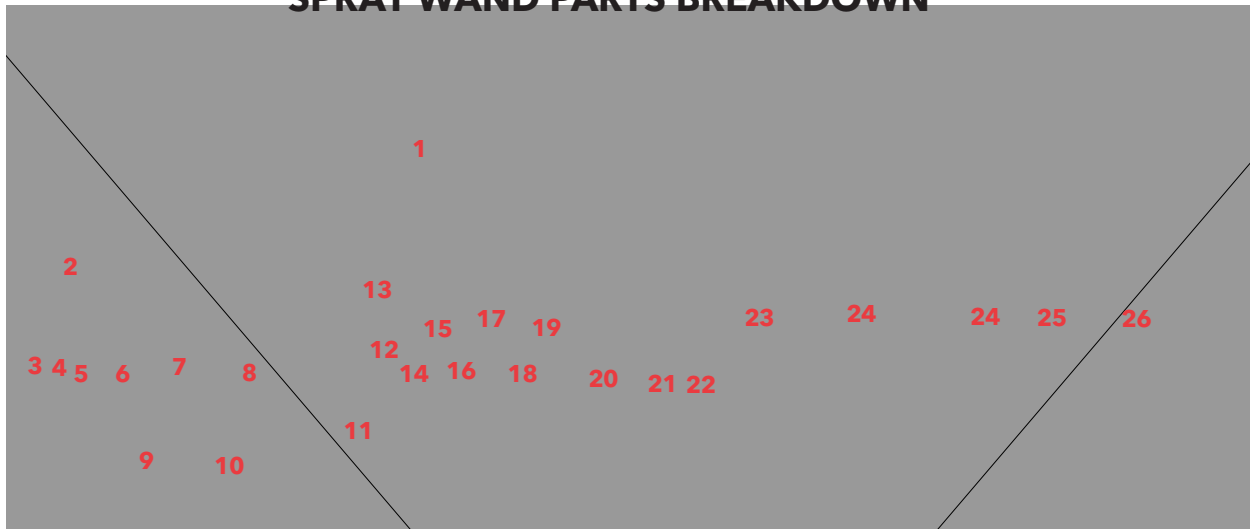

**SPRAY WAND PARTS BREAKDOWN**

REF. NO.	PART NO.	DESCRIPTION
1.	<b>19684 1NYB</b>	Housing Assembly
2.	<b>17013 1ZP</b>	Screw
3.	<b>19818 1ZP</b>	Screw
4.	<b>19819SS</b>	Washer
5.	<b>19816</b>	Spring Retainer
6.	<b>*22138 302SS</b>	Spring
7.	<b>19815</b>	Spring Guide
8.	<b>19810</b>	Trigger Guide
9.	<b>19805DEL</b>	Lock Spring Ring
10.	<b>19806FRP</b>	Trigger Lock
11.	<b>17703FRP</b>	Trigger
12.	<b>19820 420SS</b>	Roll Pin
13.	<b>17720 420SS</b>	Roll Pin
14.	<b>7622INP</b>	#6 Burr

REF. NO.	PART NO.	DESCRIPTION
15.	<b>7489 302SS</b>	Trigger Stop Spring
16.	<b>7484INP</b>	Stem Nut
17.	<b>19811</b>	Packing Screw
18.	<b>*19812AL</b>	Gasket
19.	<b>*14255 1BU</b>	Packing Cup
20.	<b>22427 18SS</b>	Stem 18"
21.	<b>7679 1</b>	Stem Guide Nut
22.	<b>*7678</b>	Stem End
23.	<b>22136</b>	Inlet Body
24.	<b>7715 18</b>	18" Wand Extension
25.	<b>*7490BRTF</b>	Valve Seat sub-assembly
26.	<b>5500 18PP</b>	Adjustable Tip (ordered separately) Not included with wand above.
	<b>AB30L</b>	Parts Kit (includes all items with *)

Please order replacement parts by **PART NO.** and **DESCRIPTION.**

## 5 GPM ELECTRIC PUMP (12981) PARTS BREAKDOWN

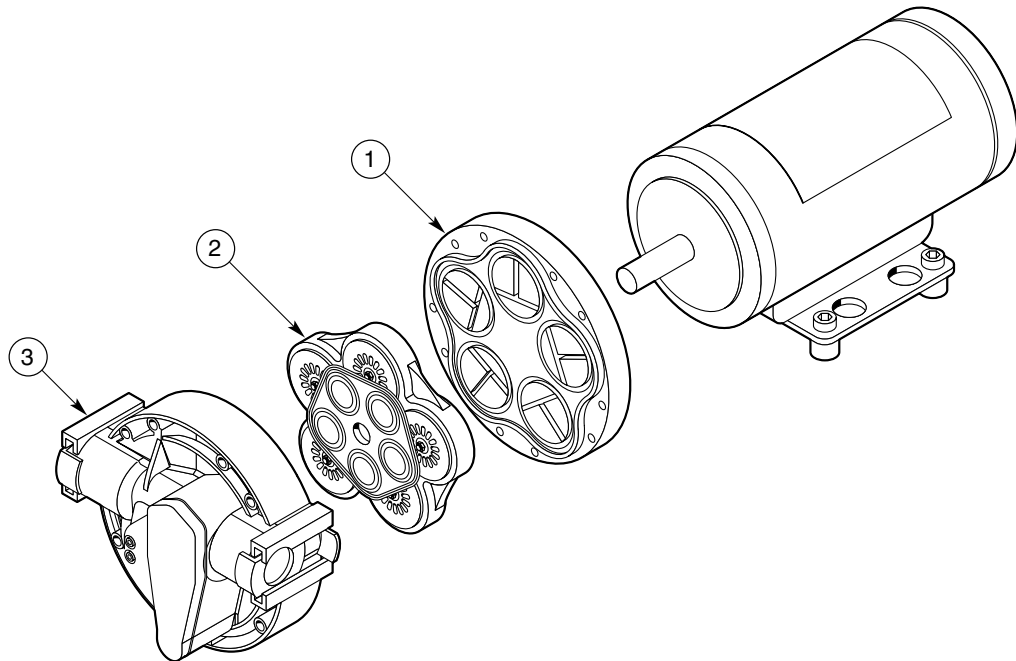

## PARTS LIST

REF. NO.	PART NO.	DESCRIPTION
1.	<b>13029</b>	Lower Housing Assembly
2.	<b>13028</b>	Valve Assembly
3.	<b>13030</b>	Upper Housing Assembly

Please order replacement parts by **PART NO.** and **DESCRIPTION.**

## SPRAYER CHECKLIST:

Downtime caused by field breakdowns is costly and time consuming. Many breakdowns can be eliminated by periodic equipment maintenance. By spending time reviewing this checklist before seasonal spraying application time and following proper after-season care, you can save time and money later.



### **WARNING: TO PREVENT SERIOUS INJURY OR DEATH:**

- Keep hands, feet, and loose clothing away from rotating parts.
- Wear protective clothing recommended by your chemical and fertilizer manufacturer when working with chemicals.

### Check Before Going To The Field :

- 1. NOZZLES**  
Check tip for excessive wear by checking for grooves in or near tip opening. Check nozzle spacing by starting at center and working outwards. Check boom for proper height.
- 2. HOSES**  
Check all hoses for worn or soft spots. Be sure all hose clamps are tightened and hoses are not kinked or pinched. Check for leakage in any lines.
- 3. TANK**  
Remove and clean agitator orifices. Check orifices for excessive wear by checking for grooves in or near orifice opening. Inspect fitting and grommets to insure they are in good condition.
- 4. CONTROLS**  
Check for leakage, plugging, or wear on all valves, fittings, etc. Clean off any build up of foreign material.
- 5. PUMP**  
Check to be sure pump turns freely.
- 6. FRAME**  
Be sure all bolts are tightened.
- 7. REPLACEMENT PARTS**  
Replace all worn or damaged parts.

### After Season Care:

**NOTE: It is important to wear proper safety equipment when cleaning the sprayer. See your chemical or fertilizer package for this information.**

1. After spraying chemicals, run water mixed with cleaners through tank, pump and all hose hookups. If wettable powder dries out in the system, it is very difficult to put back into suspension and can cause malfunction, damage or injury.
2. When cleaned, tank should have all openings closed or covered to keep dirt from entering.
3. Pump should be flushed with soluble oil and pump ports plugged to keep out moisture and air.
4. Disassemble tips and rinse with water or cleaning solution. (Appropriate for chemical sprayed).
5. Clean tip opening with a wooden toothpick. Never use wire or hard object that could distort opening.
6. Dispose of all unused chemicals or solutions in a proper and ecologically sound manner.
7. Water rinse and dry tips before storing.
8. To prevent damage due to freezing temperatures, be sure to drain all strainer bowls. Furthermore, run RV Antifreeze through the entire plumbing system to protect valves and other components.

---

**NOTE: DEMCO does not and will not make any recommendations concerning application of various chemicals or solutions. These recommendations relate to either amount or procedure of materials applied. If you have any questions regarding application of certain chemicals or solutions, contact your chemical supplier and follow chemical manufacturer recommendations.**



# **DEMCO**

4010 320th St., Boyden, IA. 51234

Phone: (712) 725-2311

Fax: (712) 725-2380

Toll Free: 1-800-54DEMCO (1-800-543-3626)

**Demco warranty policies, operator manuals, and product registration  
can be found online:**

**[www.demco-products.com](http://www.demco-products.com)**

