



Parts Manual

Mfg. No: 1696920-00
H1524E, 14.5TP 24" Steerable Dual Stage
Snowthrower



Model Components	Page
Auger Drive Group.....	4
Auger Gearbox SERVICE PARTS - 772092.....	6
Auger Housing Group.....	10
Controls Group.....	12
Decals Group.....	16
Discharge Chute Group.....	18
Engine & Frame Group.....	20
Handles Group.....	24
Traction Drive Group.....	26
Wheel & Tire Group.....	32
Torque Specification Chart.....	34

Not For
Reproduction

Auger Drive Group

Note: Unless noted otherwise, use the standard torque specifications

Mfg. No: 1696920-00

Items	Torque (Ft. Lbs.)
0030 - 0040	15 - 20
0080 - 0090	18 - 26

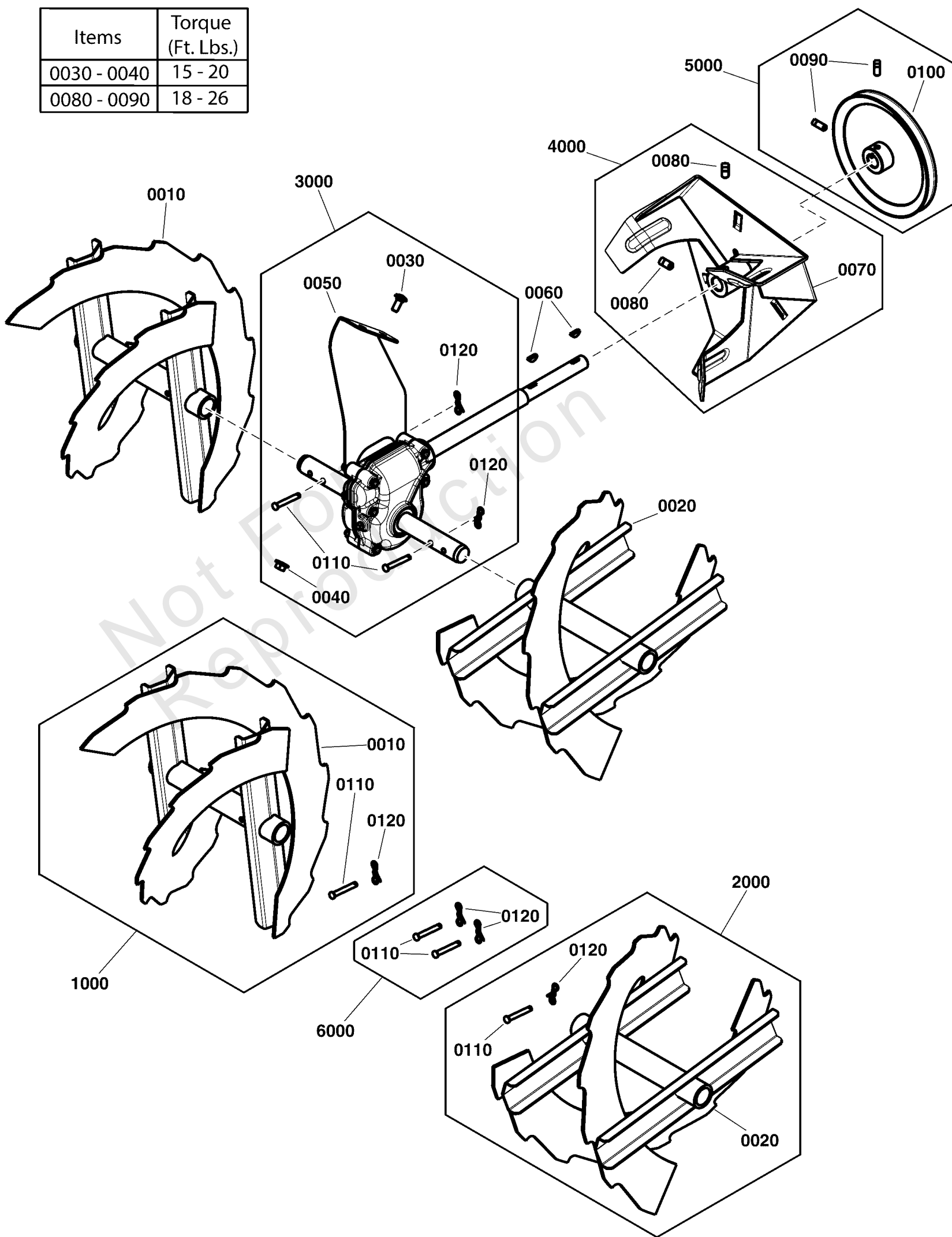

Auger Drive Group

REF NO	PART NO	QTY	DESCRIPTION
1000	772194	1	KIT, 24" Auger RH -(Incl. Ref. Nos. 0010, 0110, 0120)
0010	-----	1	WELDMENT, Auger, 24", RH, Black
0110	-----	1	PIN 1/4 X 1.750 SHEER ZC/CL
0120	-----	1	PIN 3/16 COTTER BOW TIE ZC/CL
2000	772203	1	KIT, 24" Auger LH -(Incl. Ref. Nos. 0020, 0110, 0120)
0020	-----	1	WELDMENT, Auger, 24", LH, Black
0110	-----	1	PIN 1/4 X 1.750 SHEER ZC/CL
0120	-----	1	PIN 3/16 COTTER BOW TIE ZC/CL
3000	772092	1	KIT, Gearbox -(Incl. Ref. Nos. 0030, 0040, 0050, 0060)
0030	-----	2	BOLT 5/16-18X0.625 CARRIAGE SQ GR5 ZC/CL
0040	-----	2	NUT, Hex Keps, 5/16-18
0050	-----	1	GEARBOX ASSY, HD-ZMO
0060	-----	2	KEY, 3/16 X 0.625, Woodruff
4000	772090	1	KIT, Impeller -(Incl. Ref. Nos. 0070, 0080, 0090)
0070	-----	1	WELDMENT, Impeller, Black
0080	1960474	2	SCREW, Set Square Head, Cup Point, 3/8-16 x 1/2
0090	-----	2	SCREW, Set Square Head, 16 - 18 x 5/8, G8
5000	772105	1	KIT, Auger Pulley 7.25" -(Incl. Ref. Nos. 0090, 0100)
0090	-----	2	SCREW, Set Square Head, 16 - 18 x 5/8, G8
0100	-----	1	PULLEY, Impeller, 7.250 OD, HD
6000	1750790YP	1	SHEAR PIN KIT, 1038 -(Incl. Ref. Nos. 0110, 0120)
0110	-----	2	PIN 1/4 X 1.750 SHEER ZC/CL
0120	-----	2	PIN 3/16 COTTER BOW TIE ZC/CL

Auger Gearbox SERVICE PARTS - 772092

Note: Unless noted otherwise, use the standard torque specifications

Mfg. No: 1696920-00

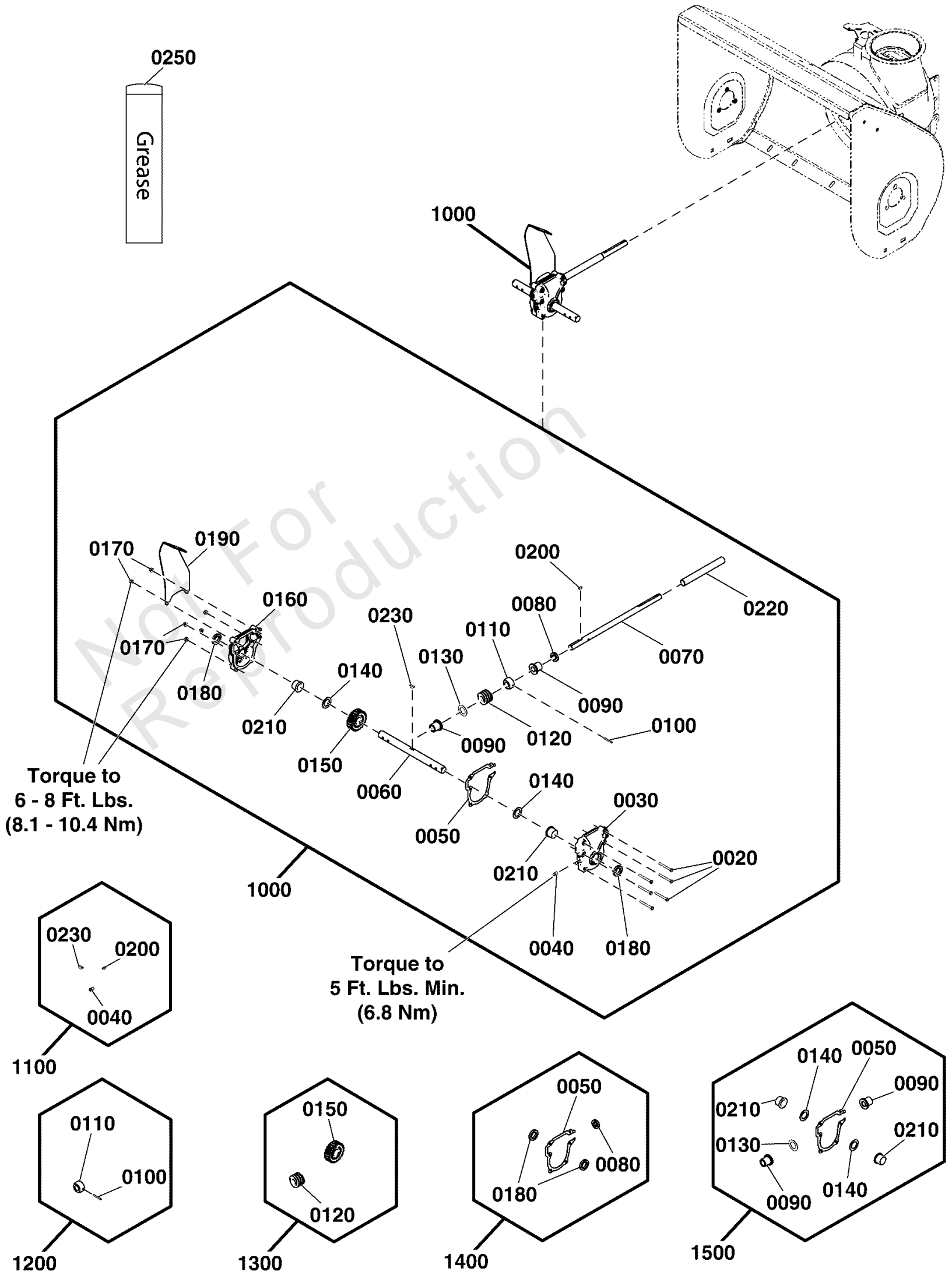

Auger Gearbox SERVICE PARTS - 772092

REF NO	PART NO	QTY	DESCRIPTION
1000	772092	1	KIT, Gearbox -(Incl. Ref. Nos. 0020 - 0230)
0020	704291	6	CAPSCREW, Hex Head, 1/4-20 X 2 1/4
0030	-----	1	GEAR CASE HALF, Left Hand
0040	1668971SM	1	TAPERED PIPE PLUG
0050	1612124SM	1	GASKET
0060	1732440SM	1	SHAFT, Auger Cutoff
0070	-----	1	SHAFT, Impeller, 17.29" L, HD-ZMO
0080	-----	1	SEAL, Oil
0090	1612149SM	2	FLANGE BUSHING
0100	2836098SM	1	PIN, Drive Lock
0110	1612127SM	1	THRUST COLLAR
0120	-----	1	WORM, LH Rolled Steel
0130	2168111SM	1	WASHER, Thrust
0140	2118315SM	2	WASHER, Thrust
0150	-----	1	GEAR, Worm, Steel
0160	-----	1	GEAR CASE HALF, Right Hand
0170	703916	6	NUT, Hex Flange, 1/4-20
0180	-----	2	SEAL, Oil
0190	772324	1	PLATE, Support
0200	703891	1	KEY, Woodruff, Plain, 3/16 x 5/8
0210	1732991SM	2	BUSHING
0220	1612111SM	1	TUBE
0230	704280	1	KEY, Woodruff, 1/4 x 3/4
0250	-----	1	GREASE, Brown Lithium Mobilux EP1 (3oz)
1100	772168	1	KIT, Plug & Key -(Incl. Ref. Nos. 0040, 0200, 0230)
0040	1668971SM	1	TAPERED PIPE PLUG
0200	703891	1	KEY, Woodruff, Plain, 3/16 x 5/8
0230	704280	1	KEY, Woodruff, 1/4 x 3/4
1200	772218	1	KIT, Collar & Pin -(Incl. Ref. Nos. 0100, 0110)
0100	2836098SM	1	PIN, Drive Lock
0110	1612127SM	1	THRUST COLLAR
1300	706853	1	KIT, Gears -(Incl. Ref. Nos. 0120, 0150)
0120	-----	1	WORM, LH Rolled Steel
0150	-----	1	GEAR, Worm, Steel
1400	772164	1	KIT, Gasket & Seal -(Incl. Ref. Nos. 0050, 0080, 0180)
0050	1612124SM	1	GASKET
0080	-----	1	SEAL, Oil
0180	-----	2	SEAL, Oil
1500	772170	1	KIT, Auger Bushing -(Incl. Ref. Nos. 0050, 0090, 0130, 0140, 0210)
0050	1612124SM	1	GASKET
0090	1612149SM	2	FLANGE BUSHING
0130	2168111SM	1	WASHER, Thrust
0140	2118315SM	2	WASHER, Thrust
0210	1732991SM	2	BUSHING
1000	772164	1	KIT, Gasket & Seal -(Includes Items 0050, 0060, 0180)
0050	-----	1	GASKET, Gear Case

Auger Gearbox SERVICE PARTS - 772092

Note: Unless noted otherwise, use the standard torque specifications

Mfg. No: 1696920-00

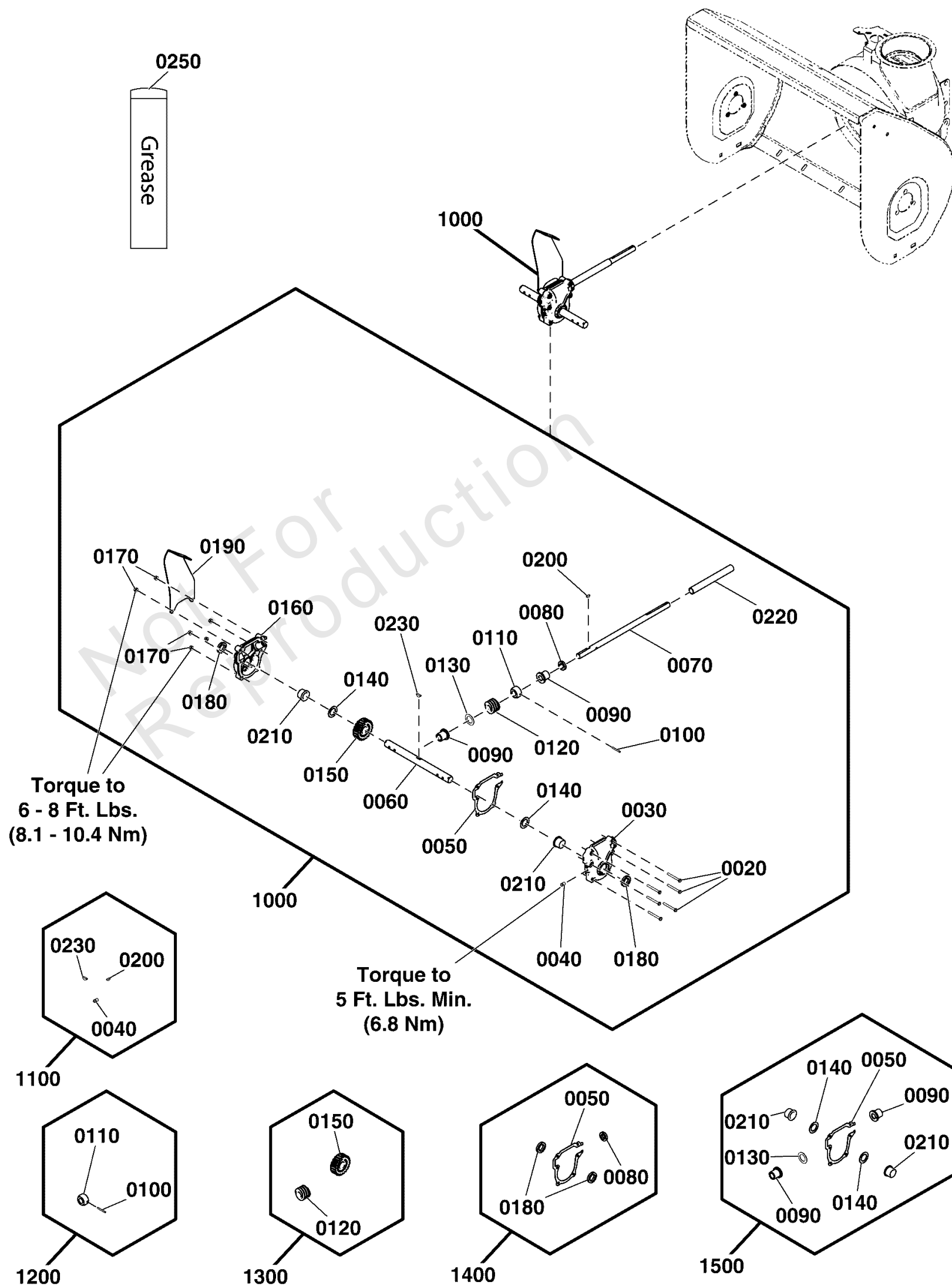

Auger Gearbox SERVICE PARTS - 772092

REF NO	PART NO	QTY	DESCRIPTION
0060	-----	1	SEAL, Oil
0180	-----	2	SEAL, Oil
2000	772170	1	KIT, Auger Bushing -(Includes Items 0050, 0090, 0130, 0140 & 0210)
0050	-----	1	GASKET, Gear Case
0090	-----	2	BUSHING, 3/4 x 1
0130	-----	1	WASHER, Thrust .76 x 1 3/8
0140	-----	2	WASHER, Thrust 1 x 1 5/8
0210	-----	2	BUSHING, 1 x 1 1/4
3000	772218	1	KIT, Collar & Pin -Includes Items 0100 & 0110)
0100	-----	1	PIN, Drive Lock, 3/16 X 1-1/2
0110	-----	1	COLLAR, Thrust 3/4 x 1 1/2
4000	772168	1	KIT, Plug & Key -(Includes Items 0040, 0060 & 0230)
0040	-----	1	FITTING, Pipe Plug
0200	-----	1	KEY, 3/16 X 0.625, Woodruff
0230	-----	1	KEY, .25X.75, Woodruff (91)

Not For Reproduction

Auger Housing Group

Note: Unless noted otherwise, use the standard torque specifications

Mfg. No: 1696920-00

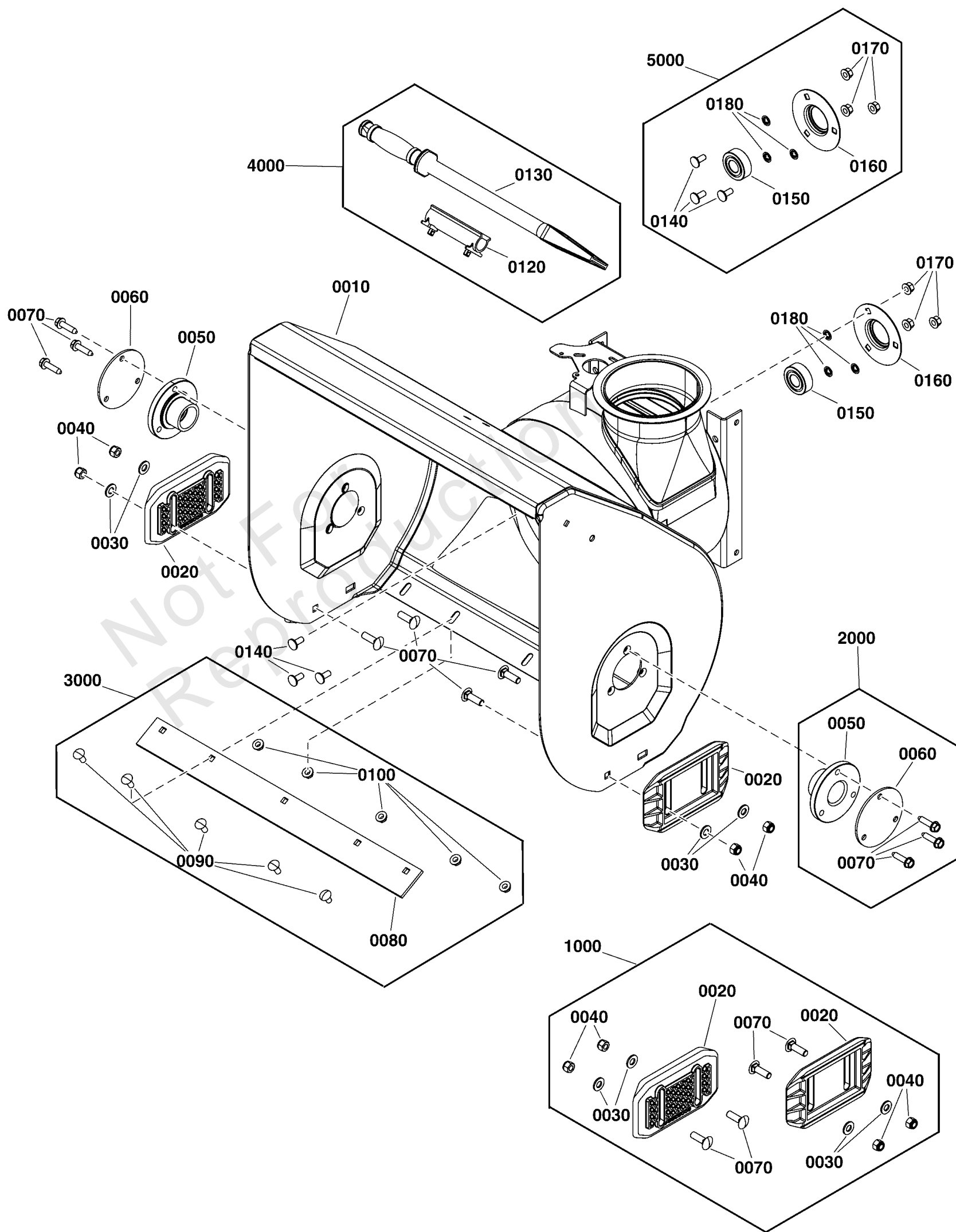

Auger Housing Group

REF NO	PART NO	QTY	DESCRIPTION
0010	-----	1	WELDMENT, Auger Housing, HD, 24", Orange -(Not a serviceable part)
1000	772086	1	KIT, Skid Shoe -(Incl. Ref. Nos. 0020, 0030, 0040, 0110)
0020	-----	2	SHOE, Skid, Reversible, Thin
0030	-----	4	WSHR .406 FLAT ZINC/CLEAR
0040	-----	4	NUT 3/8-16 GR5 HEXNYL ZINC/CLR
0110	80003604	4	BOLT,3/8-16X1-1/4,GR5,CARRIAGE,ZC/CL
2000	772166	2	KIT, Bearing Mounting Plate -(Incl. Ref. Nos. 0050, 0060, 0070)
0050	-----	1	BEARING, Flange
0060	1734932BMYP	1	COVER, Bushing
0070	-----	3	SCREW, Hex Washer Head Taptite 5/16-18 x 1-1/4
3000	772147	1	KIT, Scraper Bar 24" -(Incl. Ref. Nos. 0080, 0090, 0100)
0080	-----	1	BLADE, Scraper, 24" (Used on 1691368)
0090	-----	5	BOLT 5/16-18X0.625 CARRIAGE SQ GR5 ZC/CL
0100	-----	5	NUT 5/16-18 HEX FLNG CNTR LCK ZC/CL
4000	707549	1	KIT, CLEANOUT BRUSH STICK -(Incl. Ref. Nos. 0120, 0130)
0120	-----	1	CLAMP, Cleanout
0130	-----	1	SHOVEL, Cleanout
5000	772145	1	KIT, Bearing Mounting Plate -(Incl. Ref. Nos. 0140, 0150, 0160, 0170, 0180)
0140	-----	3	RHSSNB,5/16-18 X 3/4 GR5 ZINC/CLEAR
0150	2108202	1	BEARING-BALL 0.750ID 1.780OD 0.610LG
0160	1665982	1	RETAINER, BEARING CLEAR ZINC
0170	-----	3	NUT, 5/16-18 Hex Flange Nyloc
0180	-----	3	RETAINER,5/16X0.625,PUSHNUT,ZINC/CLEAR

Controls Group

Note: Unless noted otherwise, use the standard torque specifications

Mfg. No: 1696920-00

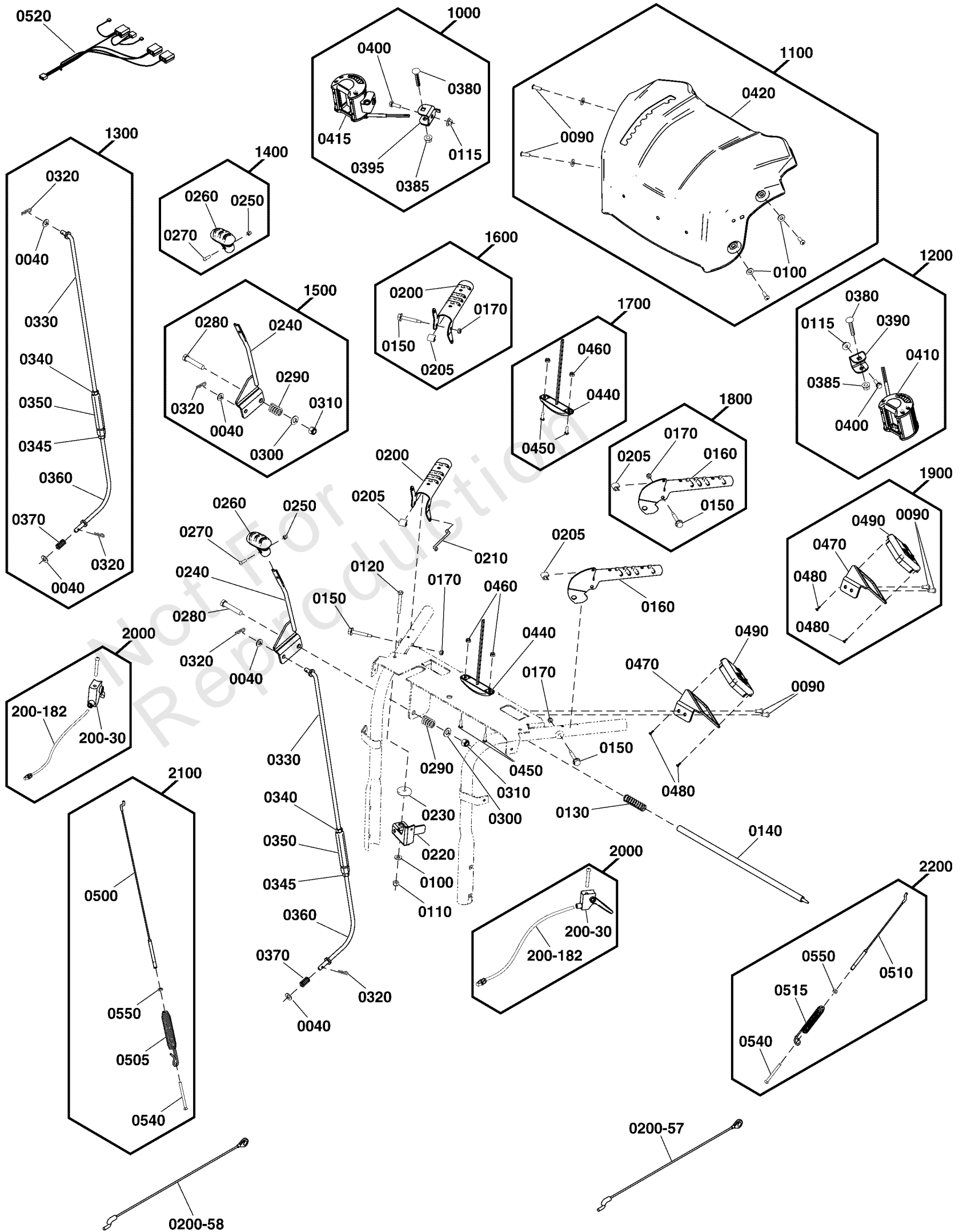

Controls Group

REF NO	PART NO	QTY	DESCRIPTION
0120	-----	1	HHCS 1/4-20X2.000 GR5 ZINC/CLEAR
0130	2108360SM	1	SPRING, Compression, 2-1/4"
0140	1733509SM	1	ROD & SPRING ASSEMBLY
0200-57	84005055	1	CABLE, Auger Drive
0200-58	84005056	1	CABLE, Traction Drive
0210	772132	1	ROD, Hold Down
0520	772130	1	HARNESS, Wiring
1000	772103	1	KIT, RH LED Light -(Incl. Ref. Nos. 0115, 0380, 0385, 0395, 0400, 0415)
0115	-----	1	NUT, Hex Flange Whiz, 1/4-20
0380	-----	1	BOLT, 5/16-18 x 1-3/4" Round Head Short Square Neck
0385	-----	1	NUT, 5/16-18 Hex Flange Nyloc
0395	-----	1	BRACKET, Light, RH, HD, Black
0400	-----	1	SCREW, 1/4-20 X .750, Hex Washer Head TT, GR5, ZC/CL
0415	-----	1	ASSEMBLY, Headlight, LED, RH
1100	772104	1	KIT, Panel Cover, Orange -(Incl. Ref. Nos. 0090, 0100, 0420)
0090	1960556SM	4	SCREW, Pan Head Torx, Taptite, 1/4-20 x 3/4
0100	-----	4	WASHER .281X.630X.065 FLAT ZINC/CLEAR
0420	-----	1	COVER, Panel, Orange
1200	772102	1	KIT, LH LED Light -(Incl. Ref. Nos. 0115, 0380, 0385, 0390, 0400, 0410)
0115	-----	1	NUT, Hex Flange Whiz, 1/4-20
0380	-----	1	BOLT, 5/16-18 x 1-3/4" Round Head Short Square Neck
0385	-----	1	NUT, 5/16-18 Hex Flange Nyloc
0390	-----	1	BRACKET, Light, LH, HD, Black
0400	-----	1	SCREW, 1/4-20 X .750, Hex Washer Head TT, GR5, ZC/CL
0410	-----	1	ASSEMBLY, Headlight, LED, LH
1300	772111	1	KIT, Speed Rod -(Incl. Ref. Nos. 0040, 0320, 0330, 0340, 0345, 0350, 0360, 0370)
0040	80004405YP	2	WASHER, 5/16, SAE Flat, Zinc/Clear
0320	-----	2	HAIRPIN.080 WIRE 1.19LG.25DIA,ZINC/CLEAR
0330	-----	1	ROD, Speed, Upper, HD
0340	80002725YP	1	NUT, 5/16-18, GR5, Zinc/Clear
0345	-----	1	NUT, 5/16-18 LH, Hex, GR 2, ZC/BLK
0350	-----	1	ADJUSTER, Shift, Hex, HD
0360	-----	1	ROD, Speed, Lower, HD
0370	-----	1	SPRING, Shift Linkage, Lower, HD
1400	770833	1	KIT, Knob, Lever -(Incl. Ref. Nos. 0250, 0260, 0270)
0250	-----	1	NUT, Acorn, M5
0260	-----	1	KNOB, Slot Speed
0270	-----	1	SCREW, Phillips Head, M5
1500	772112	1	KIT, Speed Lever -(Incl. Ref. Nos. 0040, 0240, 0280, 0290, 0300, 0310, 0320)
0040	80004405YP	1	WASHER, 5/16, SAE Flat, Zinc/Clear
0240	-----	1	WELDMENT, Speed Lever, CL/ZC
0280	80003522YP	1	CAPSCREW, 3/8-16 x 2, Hex Head, GR5, Zinc/Clear
0290	-----	1	SPRING, Compression
0300	80003536YP	1	WASHER, .406, Flat, Zinc/Clear
0310	-----	1	NUT 3/8-16 GR5 HEXNYL ZINC/CLR
0320	-----	1	HAIRPIN.080 WIRE 1.19LG.25DIA,ZINC/CLEAR
1600	772107	1	KIT, RH Clutch Lever -(Incl. Ref. Nos. 0150, 0170, 0200, 0205)

Controls Group

Note: Unless noted otherwise, use the standard torque specifications

Mfg. No: 1696920-00

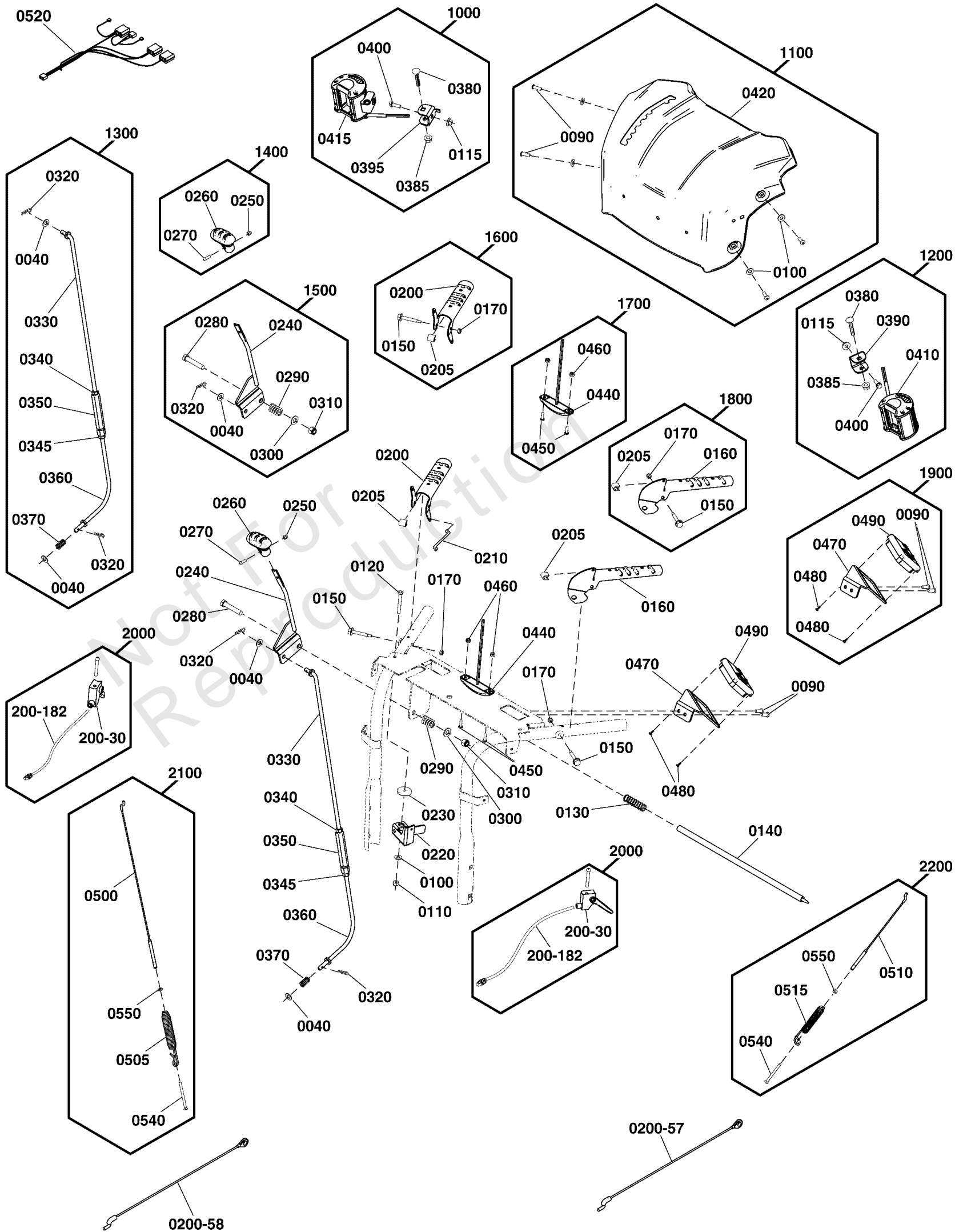

Controls Group

REF NO	PART NO	QTY	DESCRIPTION
0150	1753529YP	1	SCREW, Hex Washer Head, Shoulder 1/4-20
0170	-----	1	NUT, Hex Lock 10-24 w/Nylon Insert
0200	-----	1	LEVER, Clutch, RH, Black
0205	-----	1	TRIM, Edge, 0.05 FT
1700	772084	1	KIT, Amber Courtesy Light -(Incl. Ref. Nos. 0440, 0450, 0460)
0440	-----	1	ASSEMBLY, Amber Courtesy Light, LED
0450	-----	2	SCREW, #10-24 X 0.625, PAN HEAD, TORX 25
0460	-----	2	NUT, Hex Lock 10-24 w/Nylon Insert
1800	772106	1	KIT, LH Clutch Lever -(Incl. Ref. Nos. 0150, 0160, 0170, 0205)
0150	1753529YP	1	SCREW, Hex Washer Head, Shoulder 1/4-20
0160	-----	1	LEVER, Clutch, LH, Black
0170	-----	1	NUT, Hex Lock 10-24 w/Nylon Insert
0205	-----	1	TRIM, Edge, 0.05 FT
1900	772114	1	KIT, Echute Switch LH -(Incl. Ref. Nos. 0090, 0470, 0480, 0490)
0090	1960556SM	2	SCREW, Pan Head Torx, Taptite, 1/4-20 x 3/4
0470	-----	1	BRACKET, Switch, HD, Black
0480	-----	2	SCREW, #6-19 X .375 Plastite 48-2 Thread
0490	-----	1	ECHUTE SWITCH, LH
2000	771703	2	CABLE, Steering -(Incl. Ref. Nos. 200-30, 200-182)
200-30	-----	1	LEVER, Steering Control Assembly
200-182	-----	1	CABLE, Clutch
2100	772128	1	KIT, Traction Cable, RH -(Incl. Ref. Nos. 0500, 0505, 0540, 0550)
0500	-----	1	ASSEMBLY, Cable, Traction, RH, HD
0505	-----	1	SPRING, Traction Drive, RH, HD
0540	-----	1	SCREW, 10-24 X 2.5, Oval Head, ZC/CL
0550	-----	1	NUT, 10-24, Hex, CL/ZC
2200	772129	1	KIT, Auger-Impeller Cable, LH -(Incl. Ref. Nos. 0510, 0515, 0540, 0550)
0510	-----	1	ASSEMBLY, Cable, Auger-Impeller, LH, HD
0515	-----	1	SPRING, , Auger-Impeller Drive, LH, HD
0540	-----	1	SCREW, 10-24 X 2.5, Oval Head, ZC/CL
0550	-----	1	NUT, 10-24, Hex, CL/ZC

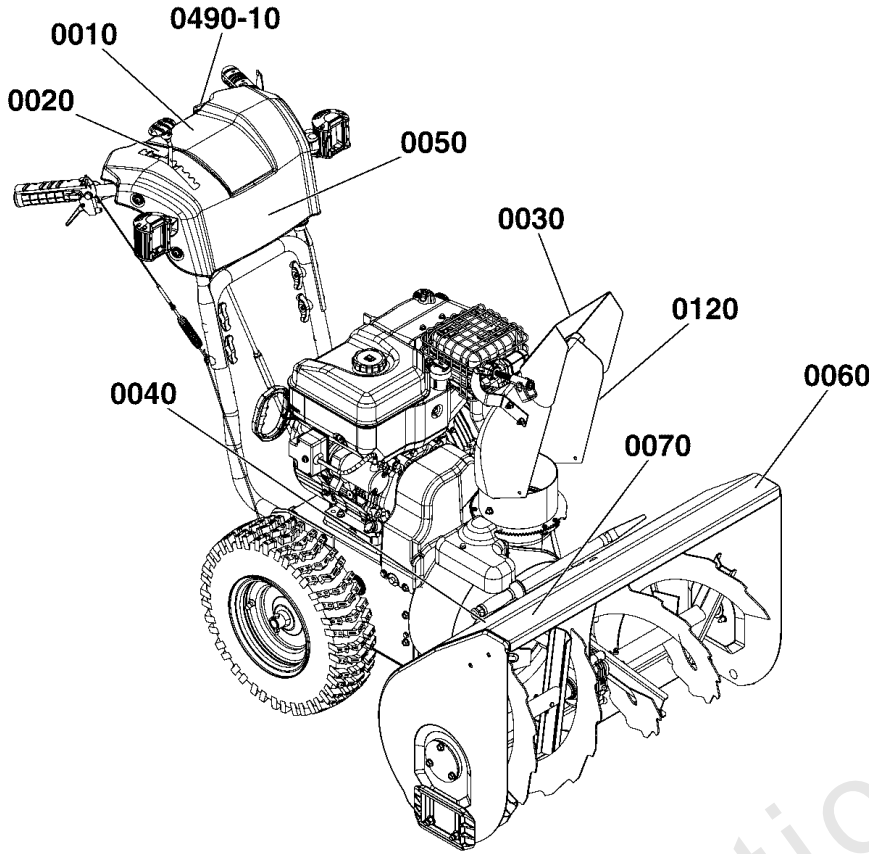

0020



0060



0120



0050

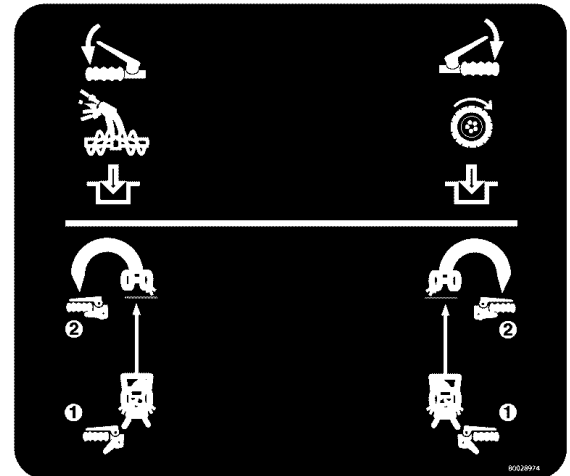

0010



0070

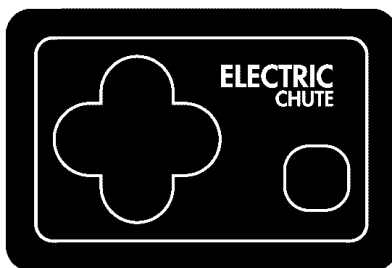

0490-10



0030

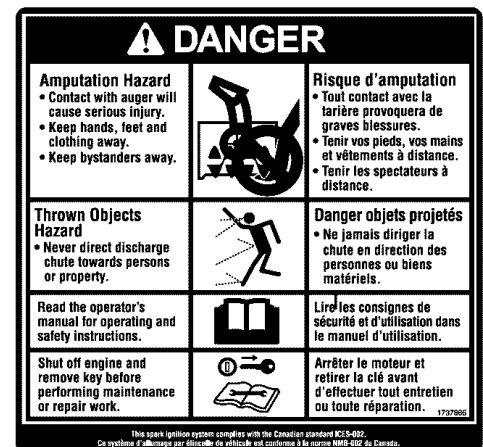

0040

Decals Group

REF NO	PART NO	QTY	DESCRIPTION
0010	84002230	1	DECAL, Controls
0020	84002231	1	DECAL, Speed Controls
0030	1737865YP	1	DECAL, Danger Chute Warning, FR/ENG
0040	1737866YP	1	DECAL, Danger Foot, FR/ENG
0050	1755901YP	1	DECAL, Simplicity Letters, RH
0060	84002233	1	DECAL, MODEL 1524
0070	1757673YP	1	DECAL, Model, SMI Logo 10.47" Long
0120	772123	1	DECAL, Velocity Throwing System
0490-10	84002299	1	DECAL, Electric Chute, LH

Not For Reproduction

Discharge Chute Group

Note: Unless noted otherwise, use the standard torque specifications

Mfg. No: 1696920-00

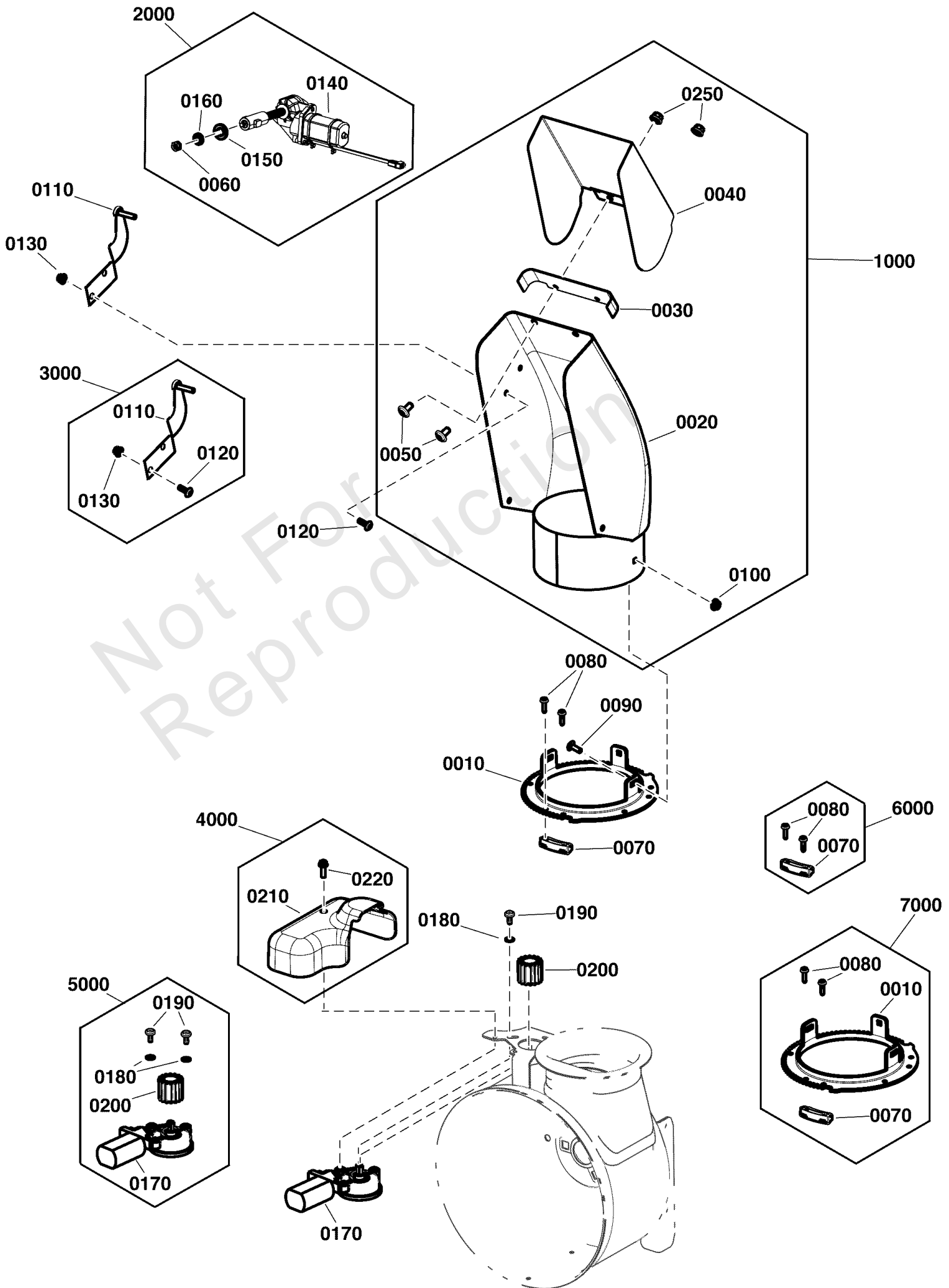

Discharge Chute Group

REF NO	PART NO	QTY	DESCRIPTION
1000	772115	1	KIT, CHUTE ASSEMBLY -(Incl. Ref. Nos. 0020, 0030, 0040, 0050, 0090, 0100, 0250, 1210)
0020	-----	1	WELDMENT, Chute
0030	-----	1	GASKET, Chute Deflector
0040	-----	1	WELDMENT, Deflector
0050	-----	2	SCREW, 5/16-18X.625, Torx, ZC/CL
0090	703159	3	BOLT, Carriage, 5/16-18 x 5/8, G5
0100	704067	3	NUT, Hex Flange, 5/16-18
0250	703115	2	NUT, Flange Nylock, 5/16-18
1210	1737865YP	1	DECAL, Danger Chute Warning, FR/ENG
6000	772135	1	KIT, Puck -(Incl. Ref. Nos. 0070, 0080)
7000	772085	1	KIT, Steele Chute Gear -(Incl. Ref. Nos. 0010, 0070, 0080)
0010	-----	1	GEAR, Tall Steel Chute, Black
0070	-----	3	RETAINER, Chute
0080	-----	6	SCREW, #10-24 X 0.750, Hex Washer HD Slot, ZC
3000	772151		KIT, Bracket -(Incl. Ref. Nos. 0110, 0120, 0130)
0110	-----	1	WELDMENT, Bracket / Stud, Black
0120	-----	2	SCREW-TRUSS HD TORX DR 1/4-20X0.750 ZC/C
0130	703463	2	NUT, Flange Nylock , 1/4-20
2000	772152	1	KIT, Motor -(Incl. Ref. Nos. 0060, 0140, 0150, 0160)
0060	703143	1	NUT, 1/4-20
0140	1737941	1	MOTOR, Chute Deflector
0150	1738244	1	WASHER, Rubber
0160	71067MA	1	WASHER, 1/4, Flat, GR5 Zinc/Clear
5000	772154	1	KIT, Motor -(Incl. Ref. Nos. 0170, 0180, 0190, 0200)
0170	-----	1	MOTOR, Actuator
0180	7091522YP	3	PHMS, TORX, 1/4C X7/8
0190	1739621YP	3	SCREW, Torx Button Head, M5 x .8 x 14
0200	1728967SM	1	PINION
4000	772153	1	KIT, Cover, Chute Rotation -(Incl. Ref. Nos. 0210, 0220)
0210	1752877YP	1	COVER, Electric Chute Rotation
0220	-----	1	SCREW, 1/4-20 X .750, Hex Washer Head TT, GR5, ZC/CL

Engine & Frame Group

Note: Unless noted otherwise, use the standard torque specifications

Mfg. No: 1696920-00

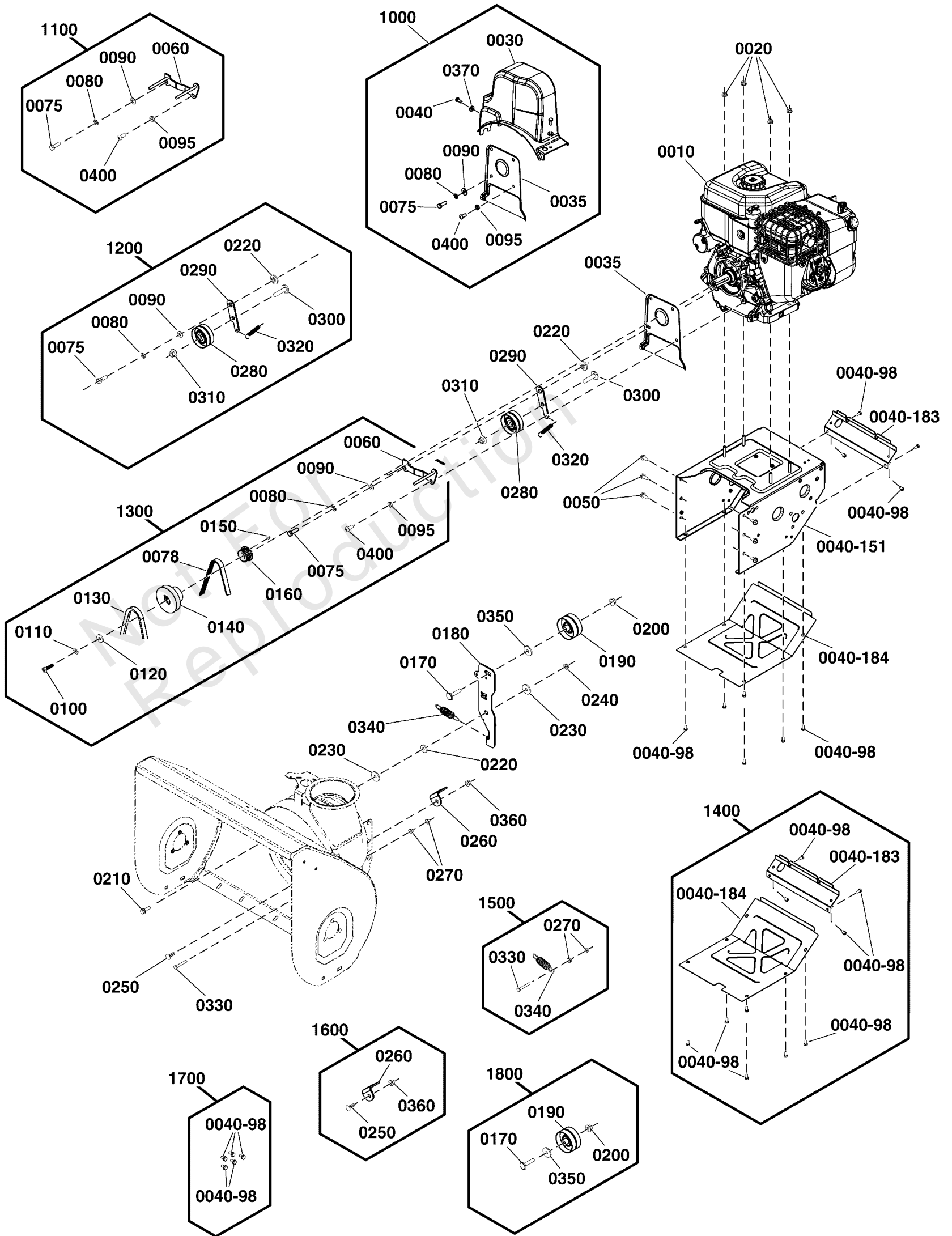

Engine & Frame Group

REF NO	PART NO	QTY	DESCRIPTION
0010	19J137-0001-F1	1	* ENGINE, 14.5TP Briggs & Stratton -(Refer to Note: *)
0020	703330	4	NUT, Hex Flange Whiz-Lock, 5/16-18
0040-151	-----	1	MOTOR BOX, Orange -(Refer to Note: **)
0050	703228	6	SCREW, Washer Head Taptite, 5/16-18 X 3/4
0180	772120	1	BRACKET, Tensioner, Auger-Impeller, HD
0210	703410	1	BOLT, Serrated Flange, 5/16-18 X 1.0
0230	-----	2	WASHER, .312 (0.34 ID X 1.25 OD X .13 Thk) ZC/CL
0240	704067	1	NUT, Hex Flange, 5/16-18
1000	84005786	1	KIT, Belt Cover -(Incl. Ref. Nos. 0030, 0035, 0040, 0075, 0080, 0090, 0095, 0370, 0400)
0030	-----	1	COVER, Belt
0035	-----	1	PLATE, Water Shield
0040	-----	2	HHCS, 1/4-20 X 0.625, GR5, ZINC/CLEAR
0075	-----	1	SCREW, 5/16-18X0.750, GR5, WHIZ-LOCK, ZC
0080	-----	1	LOCKWASHER, Spring, 5/16
0090	-----	1	WSHR SAE FLAT 5/16 ZINC/CLEAR
0095	-----	1	NUT, 5/16-24 Hex Jam Centerlock, GR A, ZC/CL
0370	-----	2	WASHER .281X.630X.065 FLAT ZINC/CLEAR
0400	-----	1	SCREW, 5/16-24X.75, BUTTON HD, BLACK OXI
1100	772138	1	KIT, Belt Guide -(Incl. Ref. Nos. 0060, 0075, 0080, 0090, 0095, 0400)
0060	-----	1	WELDMENT, Belt Guide, Upper, HD, Black
0075	-----	1	SCREW, 5/16-18X0.750, GR5, WHIZ-LOCK, ZC
0080	-----	1	LOCKWASHER, Spring, 5/16
0090	-----	1	WSHR SAE FLAT 5/16 ZINC/CLEAR
0095	-----	1	NUT, 5/16-24 Hex Jam Centerlock, GR A, ZC/CL
0400	-----	1	SCREW, 5/16-24X.75, BUTTON HD, BLACK OXI
1200	772089	1	KIT, Drive Idler Pulley -(Incl. Ref. Nos. 0075, 0080, 0090, 0220, 0280, 0290, 0300, 0310, 0320)
0075	-----	1	SCREW, 5/16-18X0.750, GR5, WHIZ-LOCK, ZC
0080	-----	1	LOCKWASHER, Spring, 5/16
0090	-----	1	WSHR SAE FLAT 5/16 ZINC/CLEAR
0220	1501065MA	2	BUSHING, Idler Bracket
0280	-----	1	PULLEY, Idler, 2.25 OD
0290	-----	1	BRACKET, Idler
0300	-----	1	SCREW-HEX HD 3/8-16X1.500 .141TH HD ZC/C
0310	-----	1	NUT, 3/8-16 Hex Flange Center Lock, Zinc Plated
0320	-----	1	SPRING, Traction Drive Idler, 3.654" LG
1300	772137	1	KIT, Belt, Guide & Pulley -(Incl. Ref. Nos. 0060, 0075, 0078, 0080, 0090, 0095, 0100, 0110, 0120, 0130, 0140, 0150, 0160, 0400)
0060	-----	1	WELDMENT, Belt Guide, Upper, HD, Black
0075	-----	1	SCREW, 5/16-18X0.750, GR5, WHIZ-LOCK, ZC
0078	770799	1	BELT, Traction Drive
0080	-----	1	LOCKWASHER, Spring, 5/16
0090	-----	1	WSHR SAE FLAT 5/16 ZINC/CLEAR
0095	-----	1	NUT, 5/16-24 Hex Jam Centerlock, GR A, ZC/CL
0100	703165	1	HHCS 3/8-24 X 1.25 GR8 ZINC/CLEAR

Footnotes:

Note:** Not a serviceable part.

Note: * Purchase engine parts from engine manufacture dealer.

Engine & Frame Group

Note: Unless noted otherwise, use the standard torque specifications

Mfg. No: 1696920-00

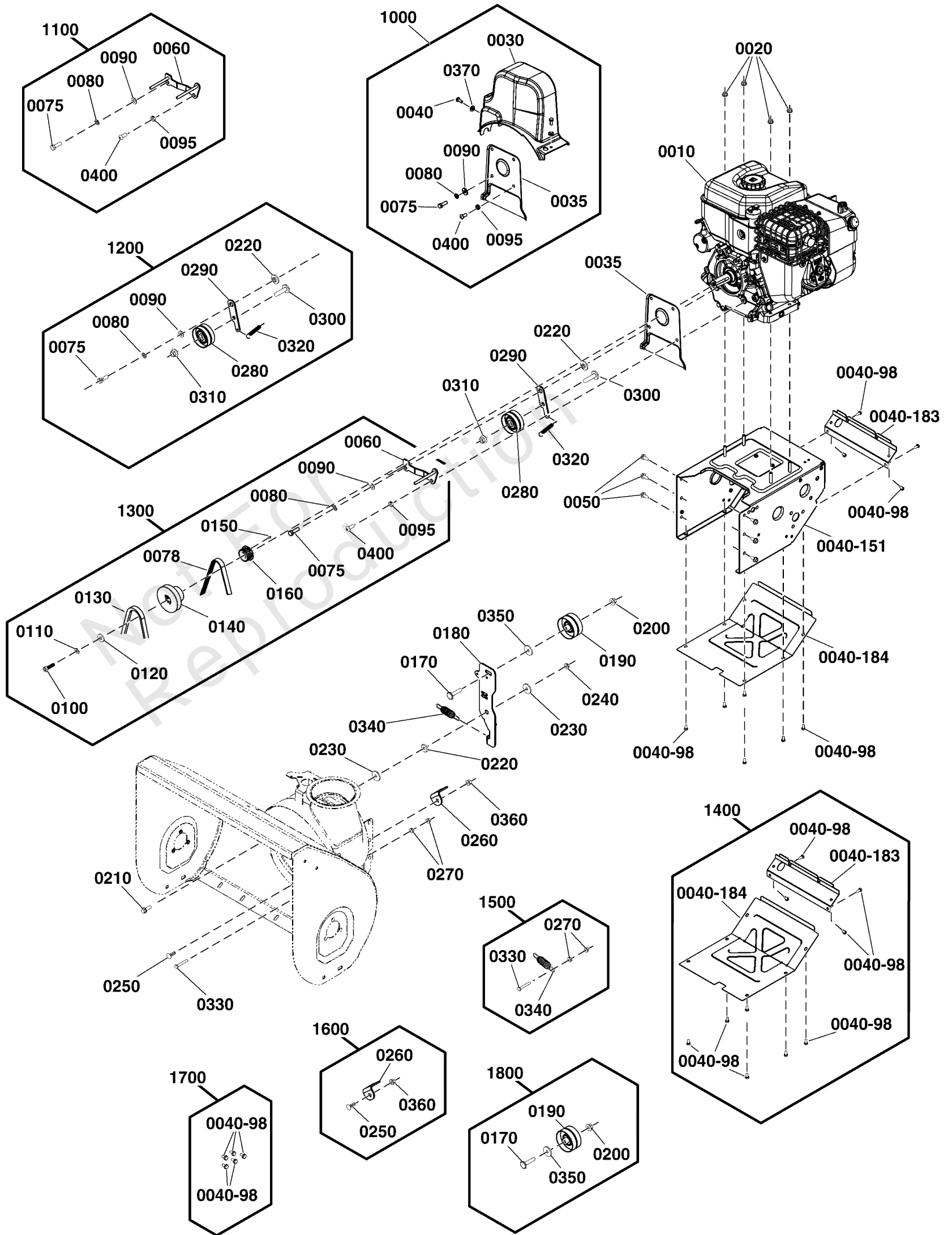

Engine & Frame Group

REF NO	PART NO	QTY	DESCRIPTION
0110	-----	1	WASHER, 3/8, Split Lock, ZC/CL
0120	704128	1	WASHER, Flat
0130	772119	1	BELT, A/HA, 36.3 Eff. Length, HD
0140	-----	1	PULLEY, Auger Impeller Drive, HD-ZMO
0150	-----	1	KEY, 3/16 X .375, Square Undersized
0160	-----	1	PULLEY, Drive
0400	-----	1	SCREW, 5/16-24X.75, BUTTON HD, BLACK OXI
1400	770819	1	KIT, Bottom Cover -(Incl. Ref. Nos. 40-0098, 40-0183, 40-0184)
0040-98	-----	10	SCREW, Hex Head W/ Flat Washer, M6 X 12
0040-183	-----	1	COVER, Back, Orange
0040-184	-----	1	COVER, Bottom, Orange
1500	772096	1	KIT, Idler Spring -(Incl. Ref. Nos. 0270, 0330, 0340)
0270	703463	2	NUT, Flange Nylock , 1/4-20
0330	703057	1	CAPSCREW, Hex Head, 1/4-20 x 1-3/4
0340	-----	1	SPRING, Idler, Auger Impeller
1600	772097	1	KIT, Belt Guide -(Incl. Ref. Nos. 0250, 0260, 0360)
0250	80004473	1	BOLT,5/16-18X1.000,ROUND HD CRRG,ZC/CL
0260	-----	1	GUIDE, Belt, Lower, HD
0360	-----	1	NUT, 5/16-18 Hex Flange Nyloc
1700	771904	6	KIT, Hardware -(Incl. Ref. No. 40-0098)
0040-98	-----	5	SCREW, Hex Head W/ Flat Washer, M6 X 12
1800	772094	1	KIT, Idler Pulley -(Incl. Ref. Nos. 0170, 0190, 0200, 0350)
0170	-----	1	SCREW, 3/8-16X1.75, .141, Hex Head
0190	-----	1	PULLEY, 2.75 OD, Idler
0200	-----	1	NUT, 3/8-16 Hex Flange Center Lock, Zinc Plated
0350	703878	1	WASHER, Flat, 13/32 x 7/8 x .083

Footnotes:

Note:** Not a serviceable part.

Note: * Purchase engine parts from engine manufacture dealer.

Handles Group

Note: Unless noted otherwise, use the standard torque specifications

Mfg. No: 1696920-00

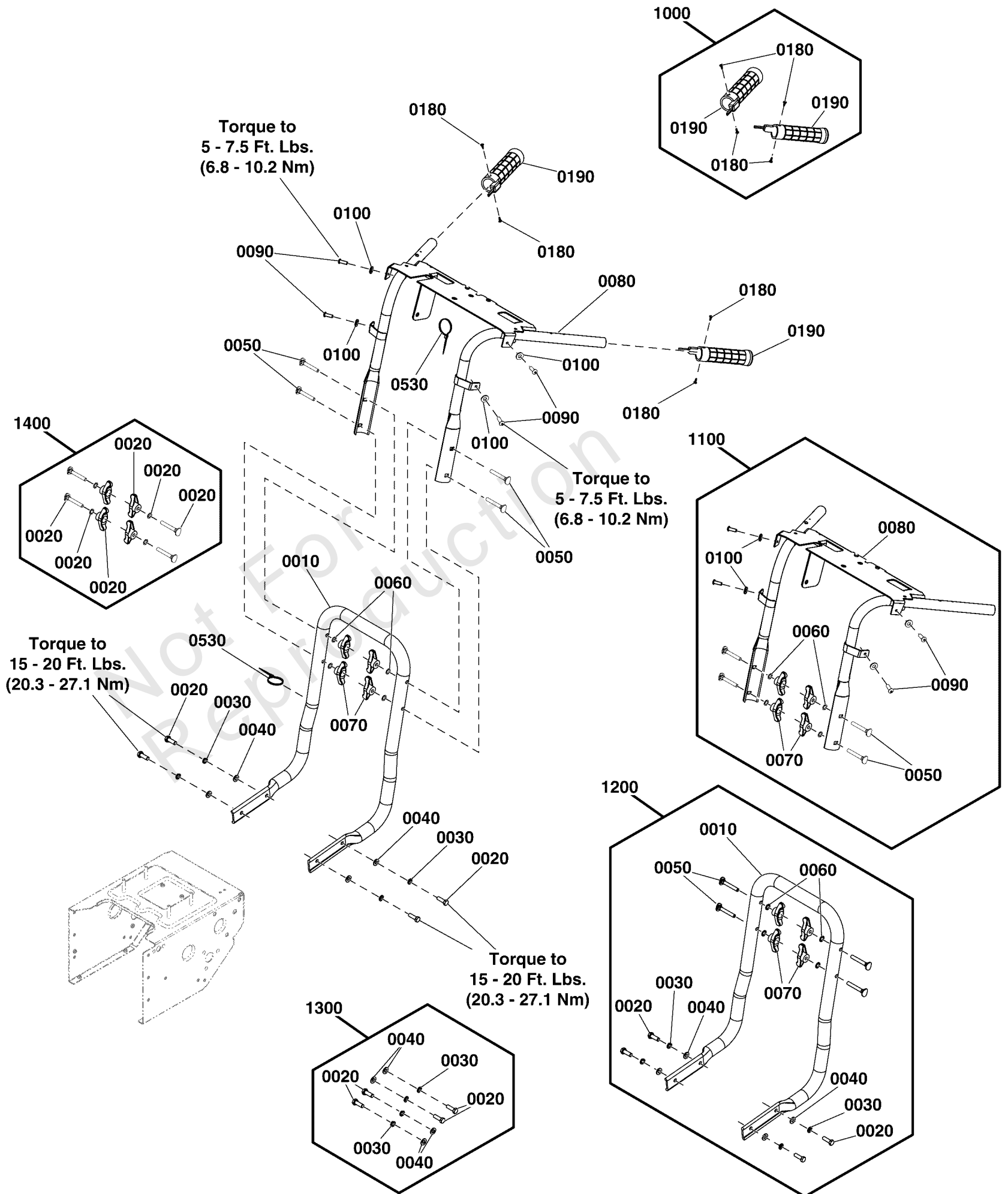

Handles Group

REF NO	PART NO	QTY	DESCRIPTION
0530	703586	9	TIE, Cable
1000	770769	1	KIT, Grip, Handle -(Incl. Ref. Nos. 0180, 0190)
0180	703044	4	SCREW
0190	-----	2	HAND GRIP, Heated, 60W
1100	84004008	1	KIT, Upper Handle -(Incl. Ref. Nos. 0050, 0060, 0070, 0080, 0090, 0100)
0050	703168	4	BOLT, 5/16-18 x 2-1/4, Carriage, Curved Head
0060	703587	4	WASHER, 5/16, Internal Lock, Zinc/Clear
0070	703065	4	KNOB, Wing, 5/16-18
0080	-----	1	WELDMENT, Upper Handle, Black
0090	1960556SM	4	SCREW, Pan Head Torx, Taptite, 1/4-20 x 3/4
0100	71067MA	4	WASHER, 1/4, Flat, GR5 Zinc/Clear
1200	772108	1	KIT, Lower Handle -(Incl. Ref. Nos. 0010, 0020, 0030, 0040, 0050, 0060, 0070)
0010	-----	1	HANDLE, Lower, Black
0020	704287	4	CAPSCREW, Hex Head, 5/16-18 x 3/4, GR5
0030	703116	4	WASHER, Split Lock, .32 x .58 x .08
0040	703350	4	WASHER, 5/16, Flat SAE, Zinc/Clear
0050	703168	4	BOLT, 5/16-18 x 2-1/4, Carriage, Curved Head
0060	703587	4	WASHER, 5/16, Internal Lock, Zinc/Clear
0070	703065	4	KNOB, Wing, 5/16-18
1300	772110	1	KIT, Lower Handle Attachment Hardware -(Incl. Ref. Nos. 0020, 0030, 0040)
0020	704287	4	CAPSCREW, Hex Head, 5/16-18 x 3/4, GR5
0030	703116	4	WASHER, Split Lock, .32 x .58 x .08
0040	703350	4	WASHER, 5/16, Flat SAE, Zinc/Clear
1400	772109	1	KIT, Handle Wing Nut Hdwe, Upper/Lower -(Incl. Ref. Nos. 0050, 0060, 0070)
0050	703168	4	BOLT, 5/16-18 x 2-1/4, Carriage, Curved Head
0060	703587	4	WASHER, 5/16, Internal Lock, Zinc/Clear
0070	703065	4	KNOB, Wing, 5/16-18

Traction Drive Group

Note: Unless noted otherwise, use the standard torque specifications

Mfg. No: 1696920-00

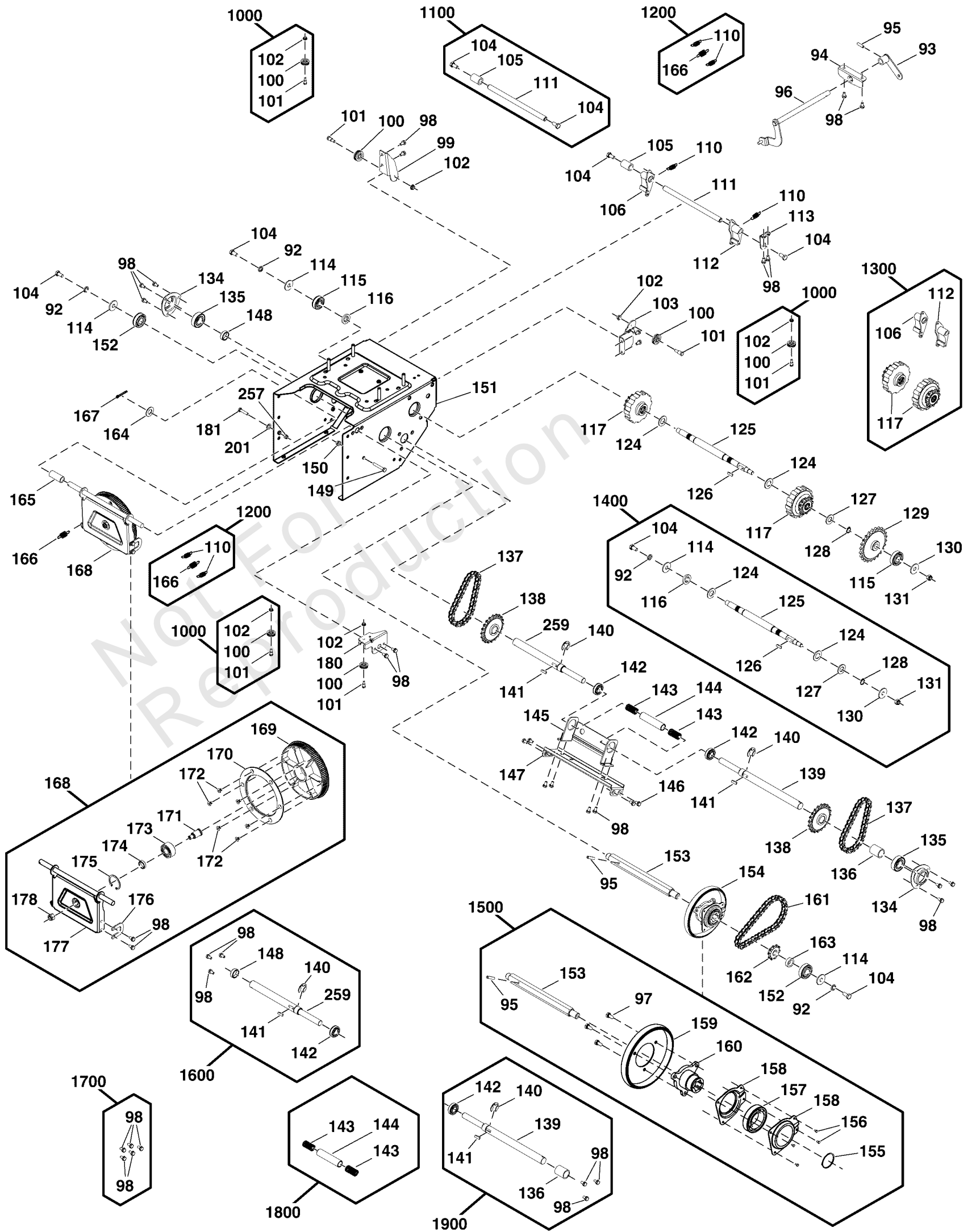

Traction Drive Group

REF NO	PART NO	QTY	DESCRIPTION
93	771916	1	ARM, Speed Select
94	771915	1	BRACKET, Speed Select
95	771912	2	PIN, Spring, 6 X 30
96	771913	1	ROD, Speed Select, Fork
99	84002884	1	BRACKET, Cable Guide, Traction Control
103	771917	1	BRACKET, Cable Guide, Auger Control
113	-----	1	BRACKET, Pawl
115	771902	2	BEARING, Ball
129	771906	1	SPROCKET, 24T
134	771911	2	RETAINER, Ball Bearing
135	771901	2	BEARING, Ball
136	771914	1	SLEEVE, Drive Shaft
137	771907	2	CHAIN, Roller, 30
138	771908	2	SPROCKET, 20T
143	-----	2	SPRING, Drive Shaft
144	-----	1	SLEEVE, Drive Shaft
145	-----	1	BRACKET, Drive Shaft
146	-----	4	SCREW, Hex Head, M8 X 16
147	-----	1	PLATE, Drive Shaft Bracket
149	-----	1	SCREW, Hex Head, M8 X 50
150	-----	1	NUT, Hex Flange Head, M8
151	-----	1	MOTOR BOX, Orange
152	771900	2	BEARING, Ball
154	-----	1	FRICITION WHEEL ASSEMBLY
161	771910	1	CHAIN, Roller, 36
162	771909	1	SPROCKET, 10T
163	-----	1	BUSHING, Hex Shaft
164	-----	1	WASHER, Flat, 13 X 24 X 2
165	-----	1	SLEEVE, Spacer, Swinging Plate
167	-----	1	PIN, Cotter, 2.5 X 30
168	771905	1	ASSEMBLY, Friction Swinging Plate
169	-----	1	PULLEY, Friction
170	-----	1	COVER, Friction Pulley
171	-----	1	SHAFT, Bearing Retainer, M10
172	-----	6	SCREW, Phillips Head, M6 X 10
173	-----	1	BEARING, Ball
174	-----	1	SLEEVE, Spacer, Swinging Plate
175	-----	1	RING, Internal Retaining, 40
176	-----	1	BRACKET, Swinging Plate
177	-----	1	PLATE, Swinging
178	-----	1	NUT, Lock, M10
180	-----	1	BRACKET, Cable Guide
181	-----	1	SCREW, Hex Head, M6 X 30
201	-----	1	WASHER, 6x12x.7, Flat
257	-----	1	NUT, Lock, M6
1000	707541	3	KIT, Pulley, Cable -(Incl. Ref. Nos. 100, 101, 102)
100	-----	1	PULLEY, Cable
101	-----	1	SCREW, M6 X 12, Hex Head Shoulder
102	-----	1	NUT, HEX FLANGE HEAD, M6
1100	771712	1	KIT, Shaft, Pawl -(Incl. Ref. Nos. 104, 105, 111)

Traction Drive Group

Note: Unless noted otherwise, use the standard torque specifications

Mfg. No: 1696920-00

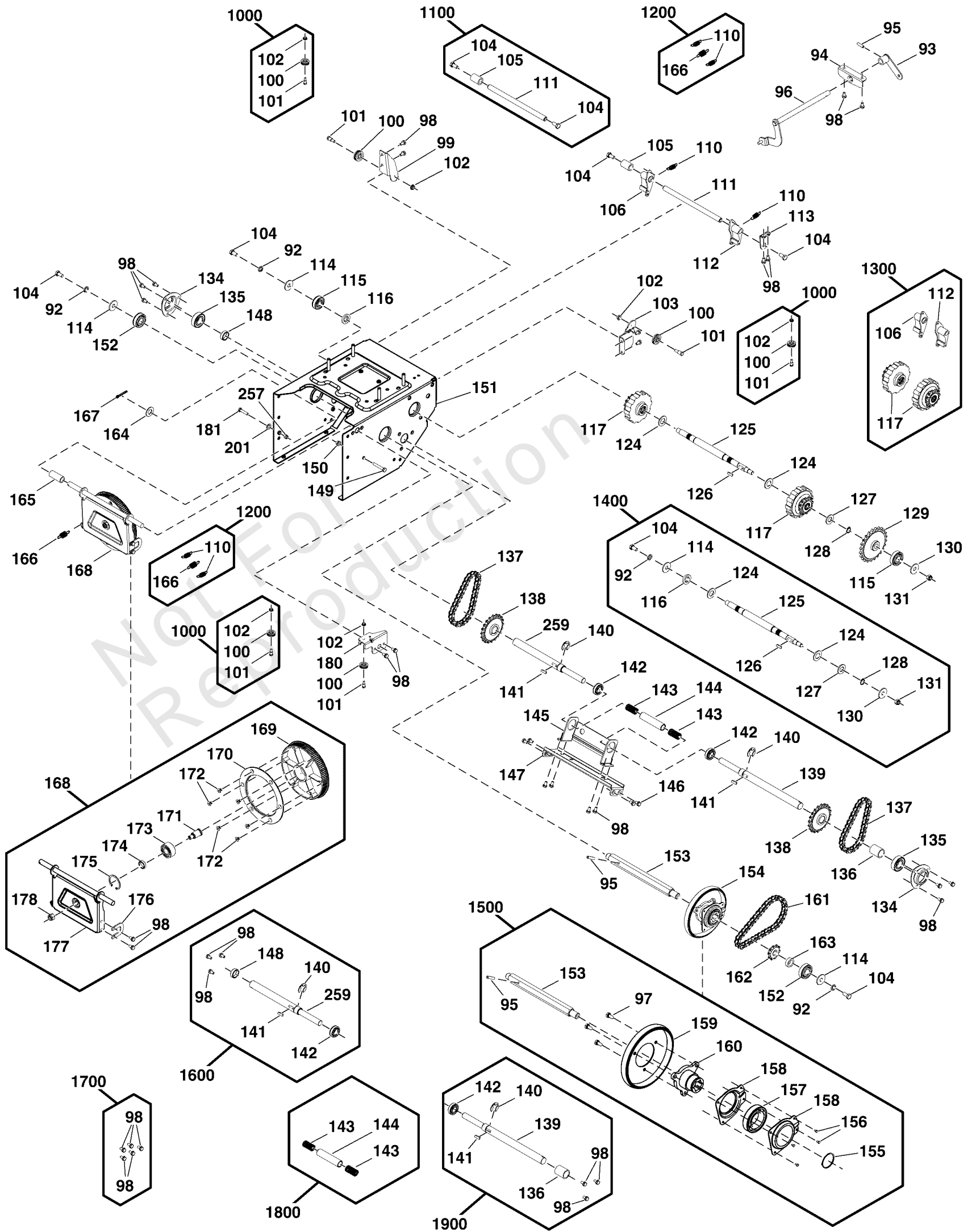

Traction Drive Group

REF NO	PART NO	QTY	DESCRIPTION
104	-----	2	SCREW, Hex Head, M8X20
105	-----	1	SLEEVE, PAWL
111	-----	1	SHAFT, PAWL
1200	771706	1	KIT, Spring, Traction Drive -(Incl. Ref. Nos. 110, 166)
110	-----	2	SPRING, Pawl
166	-----	1	SPRING, Extension
1300	771709	1	KIT, Planitary and Pawl Assembly -(Incl. Ref. Nos. 106, 112, 117)
106	-----	1	PAWL Assembly, Right
112	-----	1	PAWL Assembly, Left
117	-----	2	GEAR, Planitary Assembly
1400	771713	1	KIT, Shaft, Differential -(Incl. Ref. Nos. 92, 104, 114, 116, 124, 125, 126, 127, 128, 130, 131)
92	-----	1	WASHER, Lock, M8
104	-----	1	SCREW, Hex Head, M8X20
114	-----	1	WASHER, Flat, 8 X 28 X 2
116	-----	1	SPACER, SHAFT, DIFFERENTIAL
124	-----	2	WASHER, FLAT, 16X30X2
125	-----	1	SHAFT, DIFFERENTIAL
126	-----	1	KEY, FLAT, 5X5X22
127	-----	1	WASHER, FLAT, 14X28X2
128	-----	1	RING, RETAINING, 14
130	-----	1	WASHER, Flat, 10 X 28 X 2
131	-----	1	NUT, Lock, M10
1500	771708	1	KIT, Friction Wheel -(Incl. Ref. Nos. 95, 97, 153, 155, 156, 157, 158, 159, 160)
95	-----	1	PIN, Spring, 6 X 30
97	-----	3	SCREW, Hex Head w/ Lock Washer, M6 X 12
153	-----	1	SHAFT, Hex
155	-----	1	RING, External Retaining
156	-----	4	RIVET, 3 X 6
157	-----	1	BEARING, Ball
158	-----	2	RETAINER, Ball Bearing
159	771892	1	WHEEL, Friction
160	-----	1	HUB, Friction Wheel
1600	84002888	1	KIT, Shaft, Traction Drive RH -(Incl. Ref. Nos. 98, 140, 141, 142, 148, 259)
98	-----	3	SCREW, Hex Head W/ Flat Washer, M6 X 12
140	-----	1	WASHER, LOCK, M15
141	-----	1	KEY, WOODRUFF
142	-----	1	BEARING, BALL, DEEP GROOVE
148	-----	1	SLEEVE, DRIVE SHAFT
259	-----	1	AXLE
1700	771904	6	KIT, Hardware -(Incl. Ref. No. 98)
98	-----	5	SCREW, Hex Head W/ Flat Washer, M6 X 12
1800	84003161	1	KIT, Spring -(Incl. Ref. Nos. 143, 144)
143	-----	2	SPRING, Drive Shaft
144	-----	1	SLEEVE, Drive Shaft
1900	84002903	1	KIT, Shaft, Traction Drive LH -(Incl. Ref. Nos. 98, 136, 139, 140, 141, 142)

Traction Drive Group

Note: Unless noted otherwise, use the standard torque specifications

Mfg. No: 1696920-00

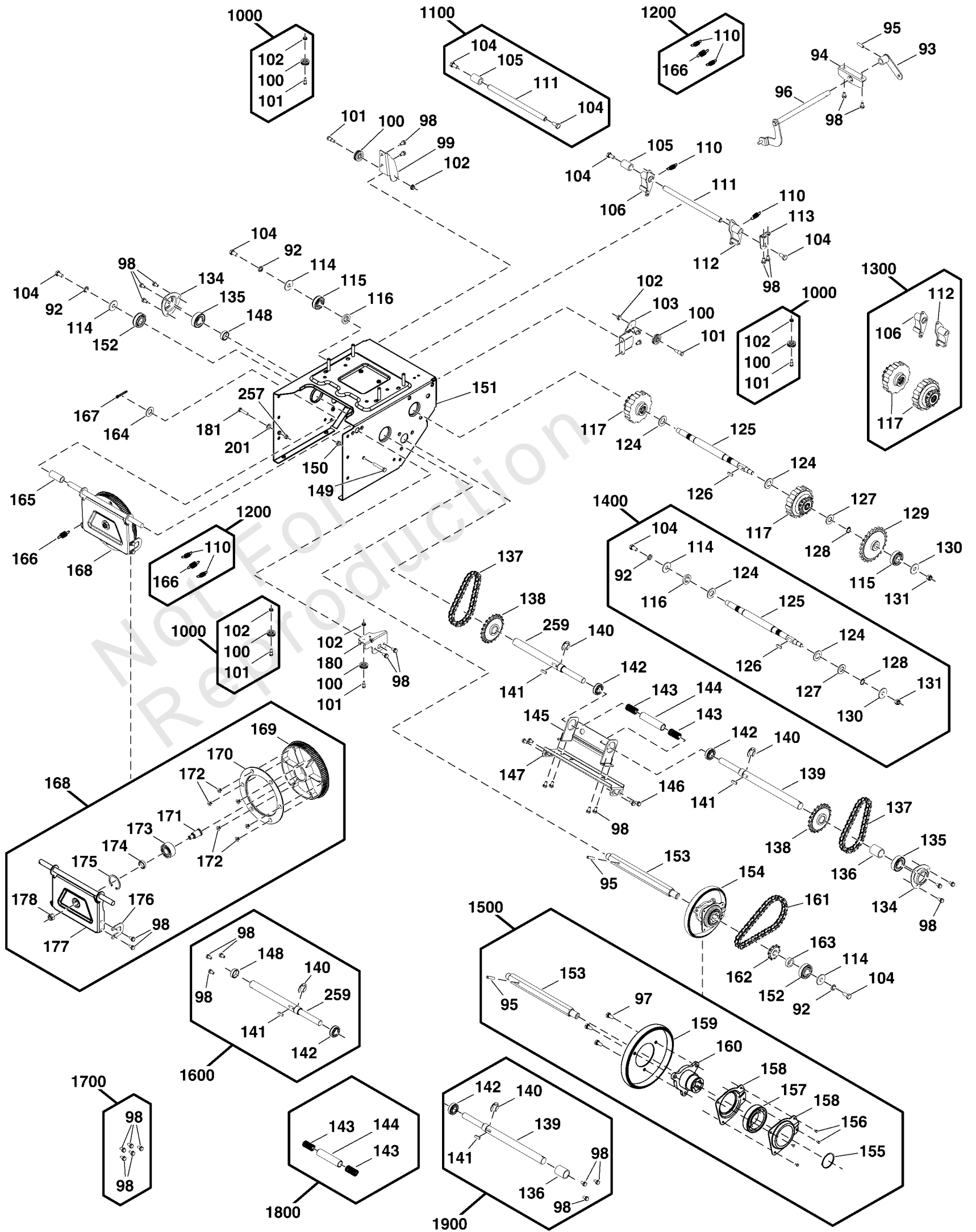

Traction Drive Group

REF NO	PART NO	QTY	DESCRIPTION
98	-----	3	SCREW, Hex Head W/ Flat Washer, M6 X 12
136	-----	1	SLEEVE, Drive Shaft
139	-----	1	AXLE
140	-----	1	WASHER, LOCK, M15
141	-----	1	KEY, WOODRUFF
142	-----	1	BEARING, BALL, DEEP GROOVE

Not For Reproduction

Wheel & Tire Group

Note: Unless noted otherwise, use the standard torque specifications

Mfg. No: 1696920-00

Torque to
6 Ft. Lbs.
(8.1 Nm)

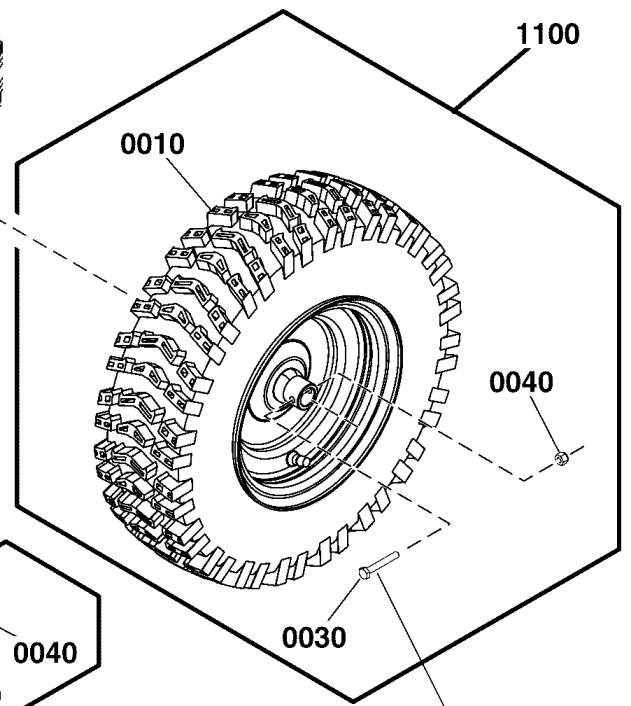
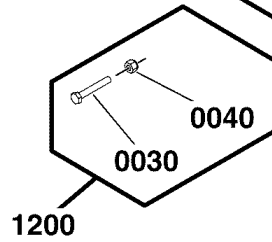
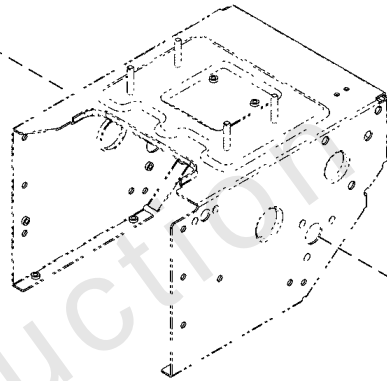
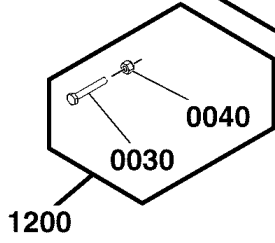
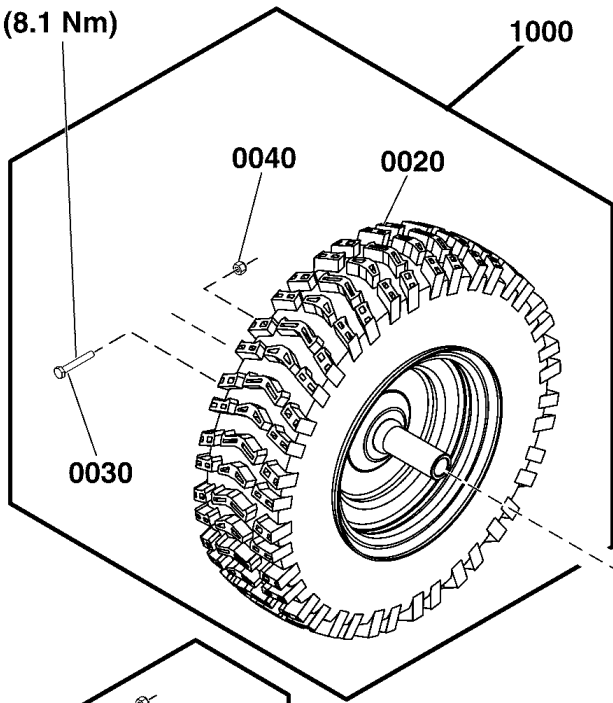

Torque to
6 Ft. Lbs.
(8.1 Nm)

Wheel & Tire Group

REF NO	PART NO	QTY	DESCRIPTION
1000	772140	1	KIT, Wheel Assy, RH, 16 X 4.80, K478 -(Incl. Ref. Nos. 0020, 0030, 0040)
0020	-----	1	ASSEMBLY, WHEEL, 4.80X8 2P K478, RH, Pewter
0030	80003543	1	HHB 1/4-20X1.750 GR5 .38THD ZINC/CLEAR
0040	-----	1	NUT, 1/4-20, Nylock
1100	772139	1	KIT, Wheel Assy, LH, 16 X 4.80, K478 -(Incl. Ref. Nos. 0010, 0030, 0040)
0010	-----	1	ASSEMBLY, WHEEL, 4.80X8 2P K478, LH, Pewter
0030	80003543	1	HHB 1/4-20X1.750 GR5 .38THD ZINC/CLEAR
0040	-----	1	NUT, 1/4-20, Nylock
1200	84004043	2	KIT, Hardware, Wheel -(Incl. Ref. Nos. 0030, 0040)
0030	80003543	1	HHB 1/4-20X1.750 GR5 .38THD ZINC/CLEAR
0040	-----	1	NUT, 1/4-20, Nylock

Not For Reproduction

Hardware Identification & Torque Specifications

Torque Specification Chart								
FOR STANDARD METRIC MACHINE HARDWARE (Tolerance ± 20%)								
Property Class	5.6		8.8		10.9		12.9	
	Class 5.6		Class 8.8		Class 10.9		Class 12.9	
Size Of Hardware	in/lbs	Nm.	in/lbs	Nm.	in/lbs	Nm.	in/lbs	Nm.
	ft/lbs		ft/lbs		ft/lbs		ft/lbs	
M3	5.88	.56	13.44	1.28	19.2	1.80	22.92	2.15
M4	13.44	1.28	30.72	2.90	43.44	4.10	52.56	4.95
M5	26.4	2.50	60.96	5.75	5.97	8.10	7.15	9.7
M6	44.64	4.3	7.3	9.9	10.3	14	12.1	16.5
M7	5.2	7.1	12.1	16.5	16.9	23	19.9	27
M8	7.7	10.5	17.7	24	25	34	29	40
M10	15	21	35	48	50	67	59	81
M12	26	36	61	83	86.2	117	103	140
M14	42	58	101	132	136	185	162	220
M16	64	88	147	200	210	285	250	340
M18	89	121	202	275	287	390	346	470
M20	126	171	290	390	405	550	486	660
M22	169	230	390	530	559	745	656	890
M24	217	295	497	375	708	960	840	1140
M27	320	435	733	995	1032	1400	1239	1680
M30	435	590	995	1350	1401	1900	1681	2280
M33	590	800	1349	1830	1902	2580	2278	3090
M36	759	1030	1740	2360	2441	3310	2935	3980
M39	988	1340	2249	3050	3163	4290	3798	5150

Torque Specification Chart						
FOR STANDARD MACHINE HARDWARE (Tolerance ± 20%)						
Hardware Grade	No Marks		SAE Grade 5		SAE Grade 8	
	SAE Grade 2		SAE Grade 5		SAE Grade 8	
Size Of Hardware	in/lbs	Nm.	in/lbs	Nm.	in/lbs	Nm.
	ft/lbs		ft/lbs		ft/lbs	
8-32	19	2.1	30	3.4	41	4.6
8-36	20	2.3	31	3.5	43	4.9
10-24	27	3.1	43	4.9	60	6.8
10-32	31	3.5	49	5.5	68	7.7
1/4-20	66	7.6	8	10.9	12	16.3
1/4-28	76	8.6	10	13.6	14	19.0
5/16-18	11	15.0	17	23.1	25	34.0
5/16-24	12	16.3	19	25.8	29	34.0
3/8-16	20	27.2	30	40.8	45	61.2
3/8-24	23	31.3	35	47.6	50	68.0
7/16-14	30	40.8	50	68.0	70	95.2
7/16-20	35	47.6	55	74.8	80	108.8
1/2-13	50	68.0	75	102.0	110	149.6
1/2-20	55	74.8	90	122.4	120	163.2
9/16-12	65	88.4	110	149.6	150	204.0
9/16-18	75	102.0	120	163.2	170	231.2
5/8-11	90	122.4	150	204.0	220	299.2
5/8-18	100	136	180	244.8	240	326.4
3/4-10	160	217.6	260	353.6	386	525.0
3/4-16	180	244.8	300	408.0	420	571.2
7/8-9	140	190.4	400	544.0	600	816.0
7/8-14	155	210.8	440	598.4	660	897.6
1-8	220	299.2	580	788.8	900	1,244.0
1-12	240	326.4	640	870.4	1,000	1,360.0

The guides and ruler furnished below are designed to help you select the appropriate hardware.



Nut, M8

Thread Diameter (mm)

Inside Diameter (in) Threads per inch

Nut, 1/2-16



Screw, M8- 1.25 x 25

Thread Diameter (mm) Distance between threads (mm) Body Length (mm)

Body Diameter Threads per inch Body Length (in)

Screw, 1/2- 16 x 2



Standard Hardware Sizing

When a washer or nut is identified as 1/2" (M8), this is the *Nominal size*, meaning the *inside diameter* is 1/2 inch (8mm metric thread diameter); if a second number is present it represents the *threads per inch* (distance between threads).

When bolt or capscrew is identified as 1/2 - 16 x 2" (M8 - 1.25 x 50), this means the *Nominal size*, or body diameter is 1/2 inch (8mm metric thread diameter), the second number, 16, represents the *threads per inch*, (*distance between threads*). The final number is the body length of the bolt or screw, 2 inches (50mm).

NOTES

- These torque values are to be used for all hardware excluding: locknuts, self-tapping screws, thread forming screws, sheet metal screws and socket head setscrews.
- Recommended seating torque values for locknuts:
 - for prevailing torque locknuts - use 65% of grade 5 torques.
 - for flange whizlock nuts and screws - use 135% of grade 5 torques.
- Unless otherwise noted on assembly drawings, all torque values must meet this specification.

Common Hardware Types

Hex Head Capscrew



Washer



Carriage Bolt



Hex Nut

Wrench & Fastener Size Guide

1/4" Bolt or Nut Wrench—7/16"	5/16" Bolt or Nut Wrench—1/2"	3/8" Bolt or Nut Wrench—9/16"	7/16" Bolt or Nut Wrench (Bolt)—5/8" Wrench (Nut)—11/16"	1/2" Bolt or Nut Wrench—3/4"
M6 Bolt or Nut Wrench—10mm	M8 Bolt or Nut Wrench—13mm	M10 Bolt or Nut Wrench—17mm	M12 Bolt or Nut Wrench—19mm	M14 Bolt or Nut Wrench—22mm

