

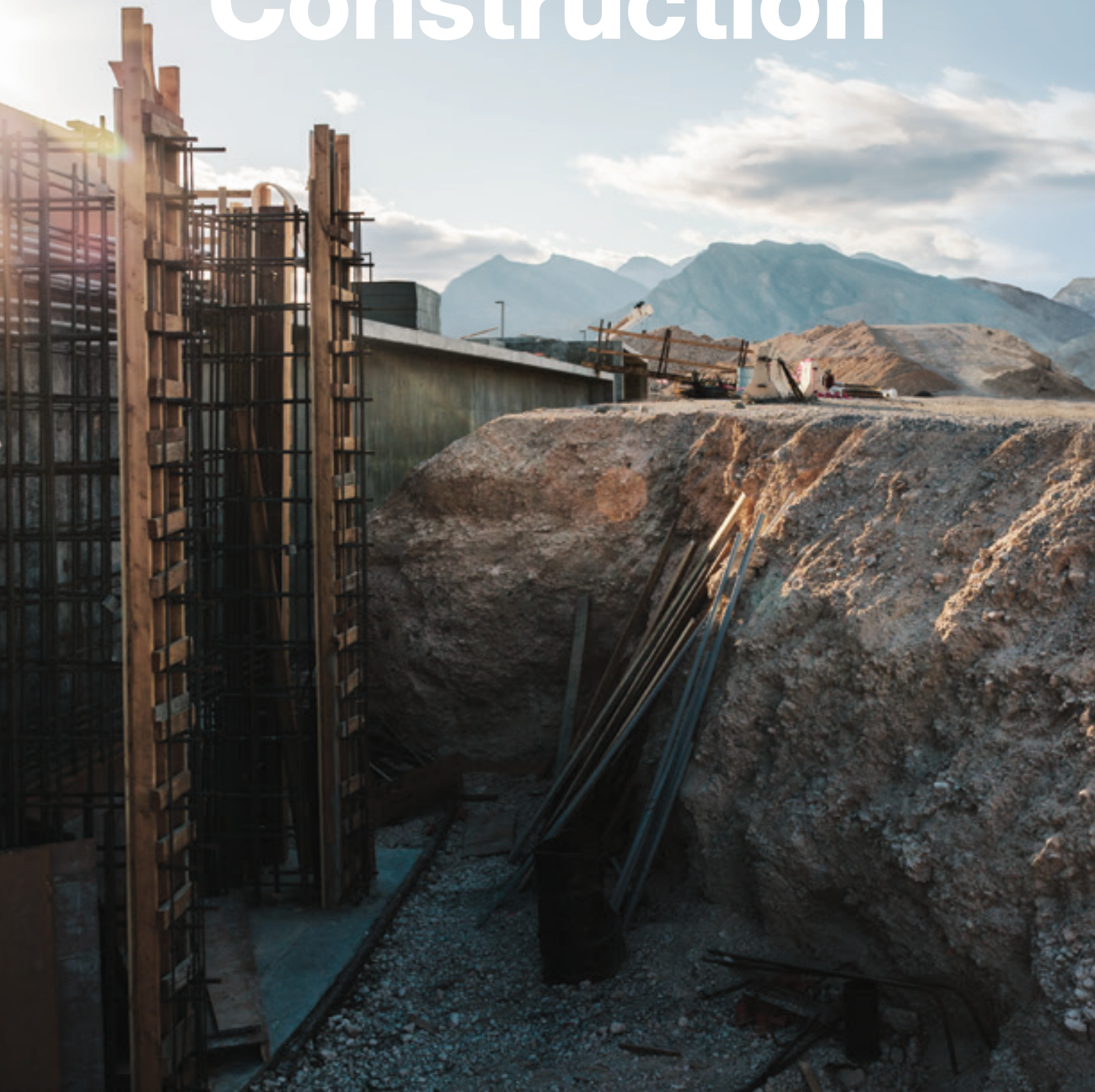

# Construction





**OUT HERE,  
TRUCKS  
ARE BORN.  
AND LEGENDS  
MADE.**



# IN CONSTRUCTION, IT'S ALL OR NOTHING.

Constructed with purpose. Prepared for anything. Mack® trucks are designed to match the demands of your most severe sites. Because we didn't just build America, we built a reputation as the leaders in construction.



## Concrete Pump

Kick mediocrity to the curb. These trucks come equipped with both the power and precision to successfully complete any concrete job.

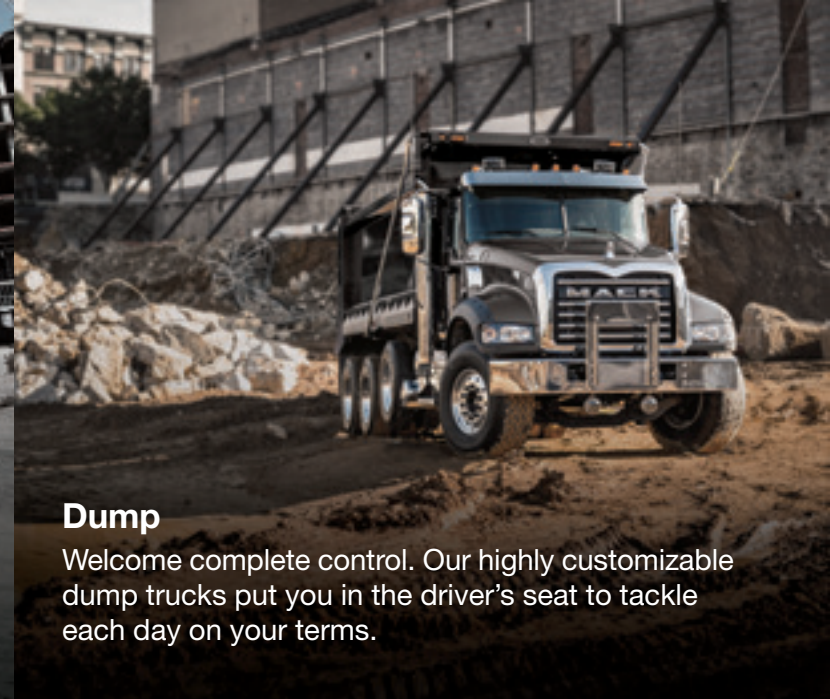

## Dump

Welcome complete control. Our highly customizable dump trucks put you in the driver's seat to tackle each day on your terms.



## Mixer

Push productivity forward. These lightweight trucks move more without sacrificing durability.

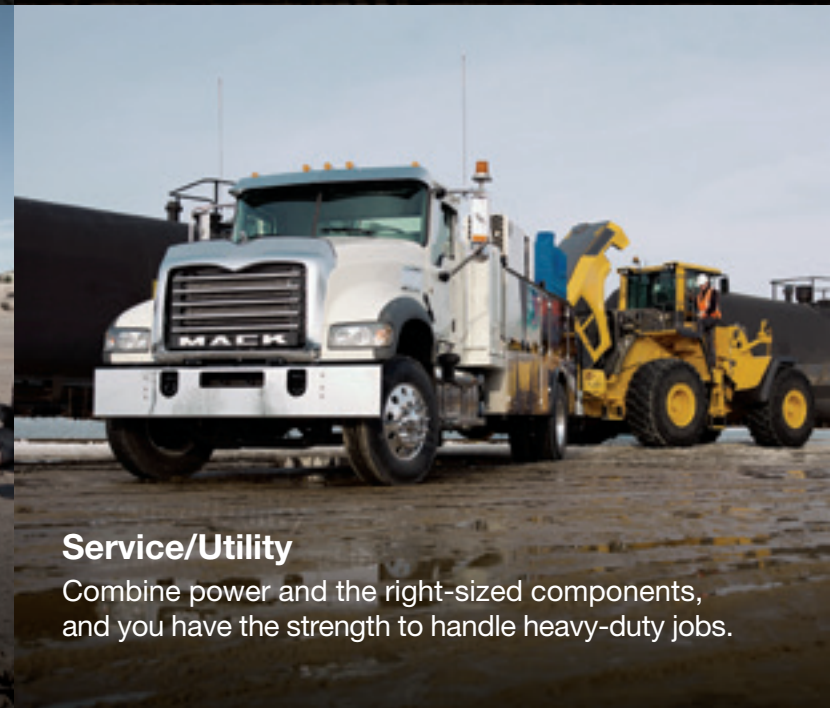

## Service/Utility

Combine power and the right-sized components, and you have the strength to handle heavy-duty jobs.



## Severe Duty

Rest is for the weak. From start to finish, these trucks are prepared to deliver no-compromise performance for the heaviest of your heavy hauls.



## Tractor

Any site, any time. Mack tractors are ready to tackle mean streets or no streets.

Granite®



TerraPro™



**WE BUILD THE  
TRUCKS THAT BUILD  
EVERYTHING ELSE.**

These are the leaders of the construction world. The team of trucks that have defined the industry for generations—and continue to push it forward. Engineered with renowned Mack reliability, we deliver the durable, modern day machines that allow you to deliver on the jobsite.

Titan by Mack



Granite® MHD



# Granite

Mack® Granite® is the unyielding foundation of any jobsite. One of the most popular and proven trucks on the road, Granite has the brains to boost your bottom line and the brawn to get the job done right.

## MP® engines

The 11-liter MP7® and 13-liter MP8® top out at 405 and 505 HP respectively giving you the muscle to shoulder heavy loads.

## Cornerstone® chassis

The *Cornerstone's* frame system gives you the versatility to choose the right thickness and strength for your demanding applications.

## Unimax® axles

These maintenance-free axles give drivers exceptional front wheel cuts, clearance and turning radius.

## Optimized driveline angle

Mack's top-mounted rear axle carriers ensure an optimized driveline angle for longer component life and a smoother operation.

## Built for your application

Granite delivers across the board. This truck can be optimized to crush any job.

## Axle Configurations

Available in single, tandem and tri-drive configurations, Granite can be customized with multiple steering, drive and auxiliary axle combinations.

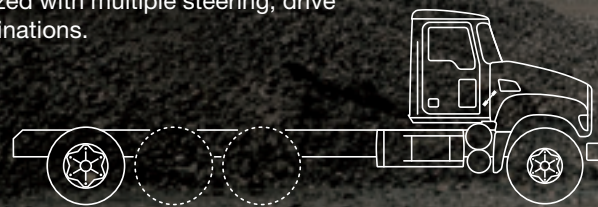

# Granite Mixer

Mack® Granite® mixers haul heavier loads and keep America moving forward.

### Weight savings

Its weight-saving design and productivity-boosting components make for greater payload.

### Optimization

We match the exact mix of Mack components to your job.

### Safety

Our roll stability advantage and exceptional brakes keep you from turning over while tackling rugged terrain. Plus, we offer outstanding visibility to make sure your Mack meets no surprises on-site.



# Granite Dump

Mack® Granite® dump trucks shrug off the abuse of the jobsite so you can focus on your job.

## Weight savings

Lightweight components and options such as lift axles help maximize hauling capacity and productivity.

## “D”-shaped fuel tank

Options like the “D”-shaped fuel tank save you critical weight and space.

## Custom frame rails

No matter what your load, Mack offers customizable frame rails to fit your construction needs.

# Granite MHD

Get nothing but rock-solid performance out of the Mack® Granite® MHD. Ideally configured for shorter runs and lighter-duty cycles, this truck cuts weight without sacrificing durability.

## 9-liter engine

MHD's lightweight, dependable 9-liter Cummins ISL engine reaches 345 HP with maximum torque rating of 1,150 lb.-ft.

## Cornerstone chassis

Built with the MHD in mind, the 7-mm steel alloy frame rail is durable and reliable.

## "D"-shaped fuel tank

This unique design allows you to hold more fuel without sacrificing space.

## Unimax axles

Featuring outstanding wheel cuts, front-end swing clearance and exceptional turning radius, the 16,000-lb. axle capacity is a great choice for the MHD.

## Galvanized steel cab

Mounted on airbags and shocks, our durable galvanized steel cab soaks up the rough stuff, so you ride in comfort.

## Axle Configurations

Granite MHD is available in single and tandem axle configurations.





# TerraPro

Meet the truck designed for best-in-industry packaging for concrete boom pumps. It has up to 505 HP with great ergonomics and visibility.

## MP® engine series

Combine fuel-efficient engines with low-end torque, and you get the MP Engine Series: the heartbeat of the Mack TerraPro.

## ClearTech™ emissions control system

Mack delivers ultra low emissions while maximizing space on chassis and frame.

## Durable chassis

Built to adapt to customer needs, TerraPro's chassis is optimized to tackle big-time construction jobs.

## Exceptional visibility

The large windshield, low-profile dash, side and rear mirrors and ergonomic seat position provide drivers with superior visibility.

## Axle Configurations

Available in single, tandem and tri-drive configurations, TerraPro can be customized with multiple steering, drive and auxiliary axle combinations.

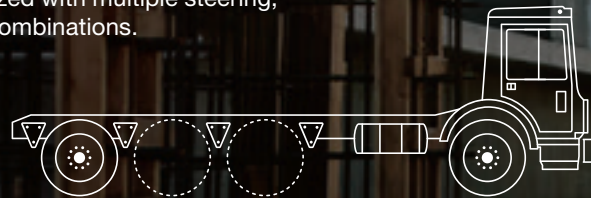

# Titan by Mack

This colossal feat of engineering refuses to be ignored. The truck houses Mack's largest-ever engine with up to 605 HP, with 2,060 lb.-ft. Because when it comes to Titan, it's all about power.

## Cornerstone<sup>™</sup> chassis

A strong frame, impressive handling and great ground clearance make this sturdy chassis ideal for punishing off-road applications.

## MP10<sup>®</sup> engine

Made for heavy transport, Titan's engine is in a league of its own boasting a best-in-class torque rating of 2,060 lb.-ft. at 1,200 RPMs.

## Application excellence

Titan's high capacity cooling package is built for handling heavy loads.

## Fuel efficiency

Intelligent fuel injectors, sophisticated software and improved air management systems provide Titan with optimum fuel efficiency.

## Decreased downtime

The 30,000-mile oil drain intervals and hassle-free servicing work as hard as you do to reduce costs and maintenance.

## Axle Configurations

Available in tandem and tri-drive configurations, Titan can be customized with multiple steering, drive and auxiliary axle combinations.

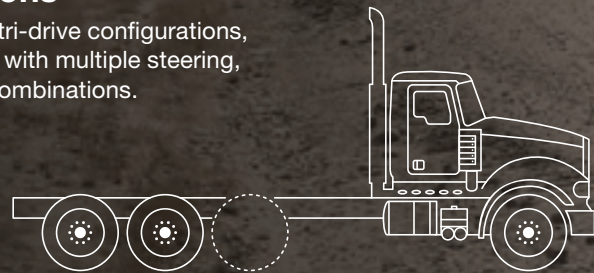

# Integrated powertrain? Try integrated everything.

It's one thing to invent the integrated powertrain. We did that more than 100 years ago, and today our revolutionary Pedigree™ Powertrain sets the gold standard.

Now, we've gone ahead and integrated the whole truck operating experience. From financing to service to 24/7 support, Mack has taken uptime and productivity to a whole new level.

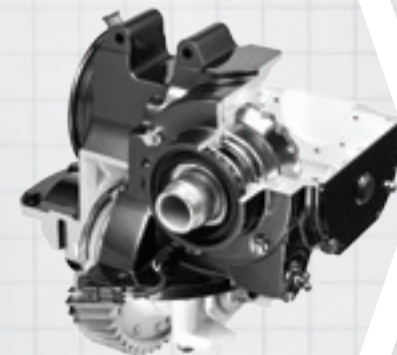
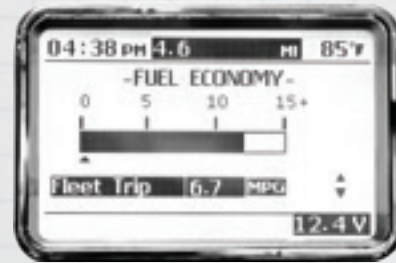
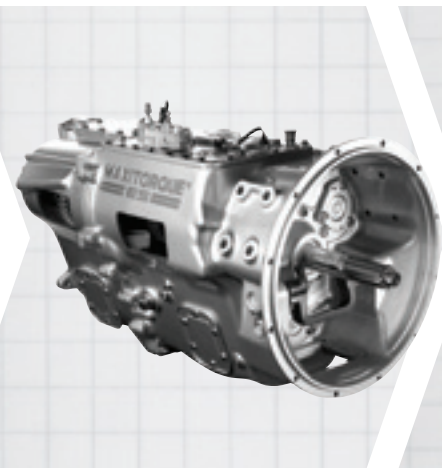
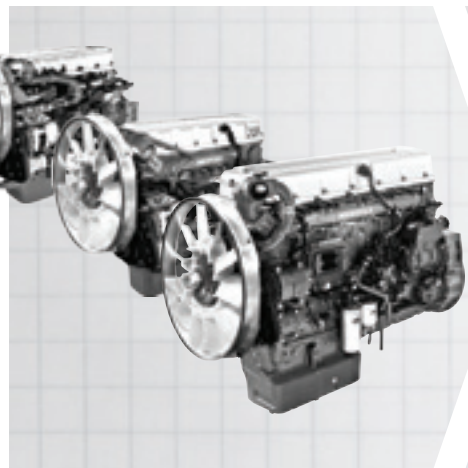

## MP® Engine Series

With muscle, torque and great fuel economy, Mack MP engines conquer the workday, mile after mile.

## Mack® Transmissions

Mack's transmissions are designed and built to perform at the highest level in the most demanding conditions, just like the rest of the truck.

## Mack® Electronics

Featuring proven V-MAC® IV electronics, Mack makes it easier to work the way you want. Effortlessly manage your truck and engine, so you save on fuel and boost your bottom line.

## Mack® Axles

Mack axles and carriers are engineered to handle the relentless punishment of heavy-duty construction applications.

## Mack® Suspensions

We've engineered Mack suspensions for reliability and outstanding performance, no matter where they go. Which, with a Mack truck, can be almost anywhere.

## Pedigree Uptime Protection

We work to deliver legendary Mack parts and services with our Pedigree Uptime Protection platform. Spend less time in the shop and more time on-site.

## The integrated leader

In 1914 we started this journey. A journey toward fully integrated trucking that's become a century of improving everything that makes your Mack a Mack.

## Powertrains that pack a punch.

Drive an integrated powertrain from the company that invented it. Equipped with dominant Mack® engines and transmissions, you increase efficiency without sacrificing power.

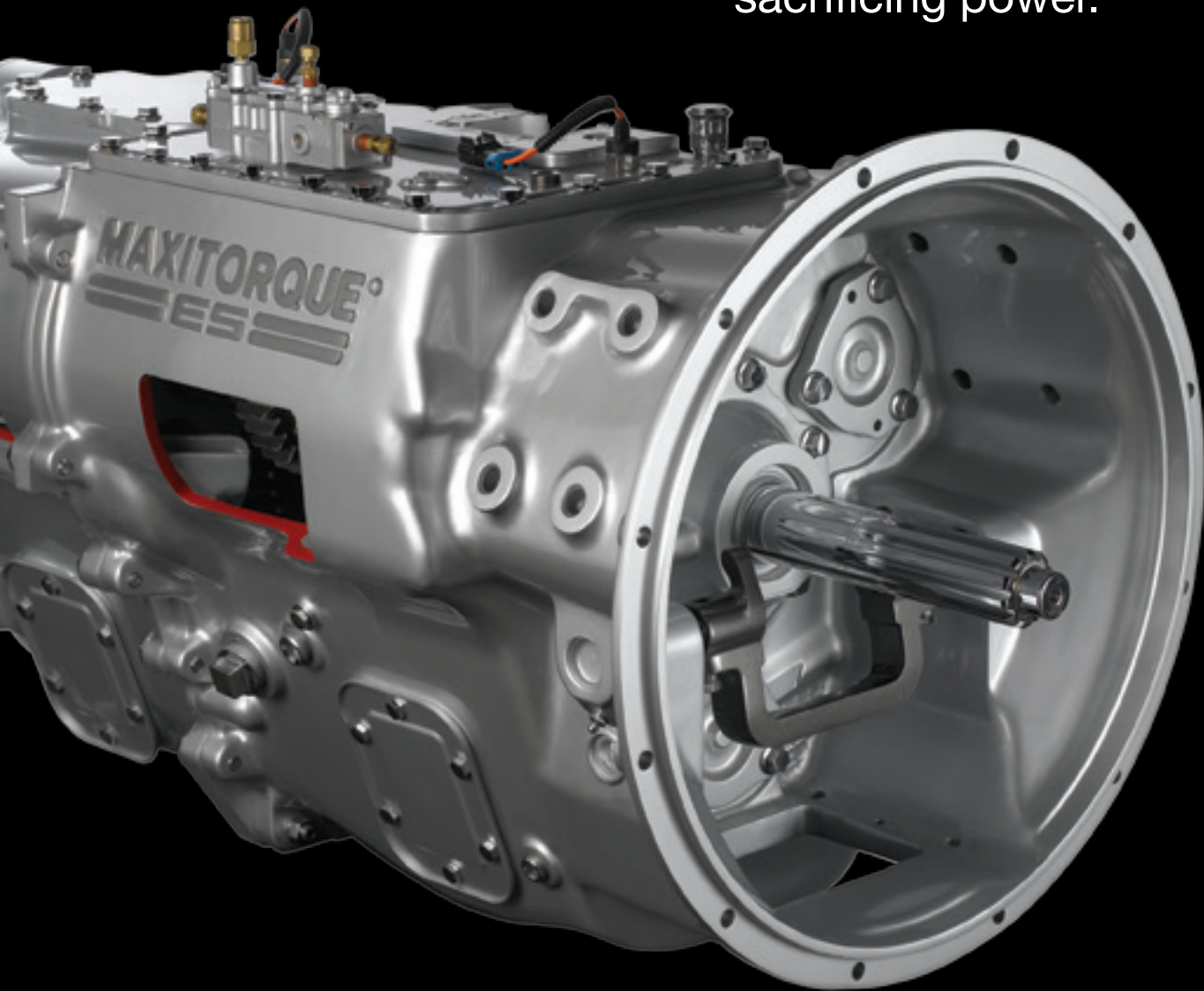

### MACK® MAXITORQUE® TRANSMISSION

The powerful Mack Maxitorque transmission is available in nine to 18 speeds. It features the industry's only triple-countershaft design and easy shifting for increased durability and smooth gear transitions. Maxitorque has seven PTO positions to help you master your application's demands.



### MACK® MP7® ENGINE

The 11-liter MP7 engine is built for optimal fuel-efficiency. Available in Mack® Granite and TerraPro models, this lightweight engine has a HP range from 325 HP to 405 HP and torque ratings from 1,200–1,560 lb.-ft.

### MACK® MP8® ENGINE

The MP8 blends fuel economy, power and increased uptime. Offered on Granite and TerraPro models, its 13-liter engine has an optimal HP range from 415 HP to 505 HP with torque from 1,570–1,760 lb.-ft.



### MACK® MP10® ENGINE

Built exclusively for Titan, the MP10 is Mack's largest-ever engine. It forcibly delivers up to 605 HP and torque ratings of 2,060 lb.-ft. at 1,200 RPMs when you need the strength to move mountains.



Axles and suspensions provide the foundation for Mack's reputation of rugged reliability. They offer increased durability for a smoother ride, because the only thing you should feel on the job is complete control.

**Rough work  
requires a  
smooth ride.**

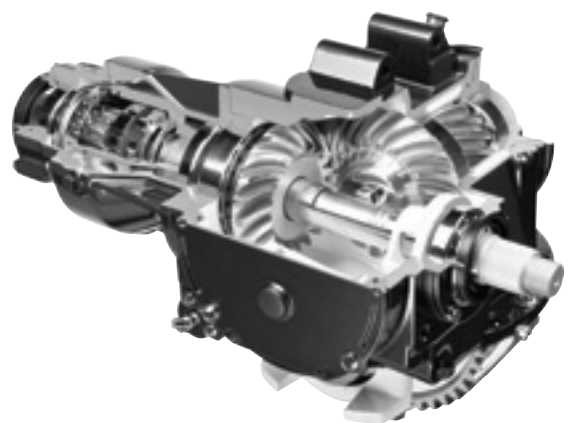

#### **MACK® AXLES**

Proprietary Mack Axles provide greater articulation on the most demanding construction sites. Our C150/151 top-mounted carriers deliver more efficient power to the wheels with less parasitic loss than with front-mounted carriers.

Mack® suspensions offer improved stability, smoother ride and greater return on investment than the competition. Through integrated design and engineering, Mack continues to raise the performance bar for construction trucks with its *mRIDE* and Camelback suspensions.

#### **MACK® CAMELBACK**

The Camelback suspension is built with increased stability to handle the stress of off-road and severe duty trucking. This tried-and-true suspension allows for better steering and reduced tire wear. Camelback is available from 38,000- to 65,000-lb. ratings.

#### **MACK® mRIDE**

With *mRIDE*, Mack delivers the next generation in spring suspensions to ease the workload for construction trucks. This suspension's extreme articulation and constant ground contact for all wheels maximizes traction and improves stability. Driver comfort takes front seat in this design, so your ride isn't as rough as your workload. Mack *mRIDE* is available in 40,000-, 46,000- and 52,000-lb. ratings.



# Take control of quality and keep your truck running strong with Pedigree Uptime Protection.

This integrated platform keeps your Mack operating at peak performance and benefits your bottom line. It's just another way Mack's got your back.

---

## **BULLDOG® PARTS PURCHASING**

We make it easy to keep your truck ready for the road with Mack Genuine Parts. All you need is the internet. You have full 24/7 access to pricing inquiry and over 500,000 vendor brand parts. And we don't offer just any parts and pricing. Our VIN-specific parts catalogue and price verification allow you to locate everything you need to make it a perfect fit.

---

## **BULLDOG® SERVICE MANAGEMENT**

We're dedicated to serving you and your truck. That's why, with the help of MACK ASIST, we provide a full-service communication and support center for fleets and owner-operators in the United States and Canada. This web-based tool partners with Mack OneCall® to increase uptime by offering multiple language breakdown support, arranging towing services and delivering real-time online case tracking.

---

## **BULLDOG® ASSET PROTECTION**

Stop truck maintenance problems before they start. Mack offers a variety of programs—including electronic CSA inspections—made to keep your engine, transmission and chassis working up to tough Mack standards.

---

## **BULLDOG® FINANCING**

Drive on your terms. No two businesses are alike, so Mack offers financing to meet your specific needs with specialized loans, leases and payment plans. From short-term rental agreements to operating and full-service leases, when you're in a Mack you're sure to be the envy of the jobsite.

---

## **MACK® GENUINE PARTS**

We've built our name around Mack Genuine Parts. They're engineered to provide dependability, peak performance and retain the purity of your truck. Mack's balanced design principles keep each part of your integrated system of components performing seamlessly together.



---

**COAST TO COAST SERVICE**

Every truck is supported by more than 500 authorized dealers and parts and service locations coast to coast, and Mack's network of qualified service facilities includes more than 5,000 locations. When you need assistance, Mack's extended network is ready to deliver.

---

**GUARDDOG<sup>®</sup> CONNECT**

GuardDog Connect is Mack's telematics-based system that unites your truck with a 24/7 network of support staff and repair centers. If something happens to your truck on the job, GuardDog Connect detects the problem instantly—usually before you know anything's wrong. This increases uptime, eliminates maintenance surprises, joins you to a live service network and provides you with peace of mind.

---

**ONECALL<sup>™</sup> COMPLETE CARE**

OneCall picks up where GuardDog leaves off. If GuardDog sniffs out trouble, OneCall communicates the issue to dealers who offer round-the-clock jobsite assistance anywhere in the United States and Canada.

**Everything your Mack needs.  
Every place you need it.  
America's truck knows no boundaries.**



**MACK<sup>®</sup>  
TRUCKS  
ARE BUILT  
TO BUILD.**







**1-800-922-MACK**  
**MackTrucks.com**

©2014 Mack Trucks, Inc. All rights reserved. Mack, Mack and the Bulldog design, Bulldog and all other marks contained herein are registered trademarks of Mack Trucks, Inc. and/or Mack Trucks, Inc. affiliated companies. All other marks contained herein are the property of their respective owners.

BRO-CONSTR-0214-VSA-13M